

# Singapore Biology League 2024

## Main Problems

---

### Problem Authors



Leo Kee Kiat, Ethan

Wang Yuting

Ang Jan Syi

Lai Le Hao Jerome

Soh Sze Hian, Lionel

Zhan Xiaoyan

Alicia Jocelyn Tjokro

Owen Ong JunHeng

Nayantara Liz

Debraath Pahari

Mayenne Tan

Ye Chen Rui

All figures are credited in the answer document.

# Problems

P01: Belobog Camping Trip .....	1
P02: Ramachandran Plots.....	7
P03: Family Guy.....	11
P04: Feathers and Mr. Birdy.....	16
P05: Gummyfish .....	18
P06: Modifications.....	21
P07: The Squarepants Extended Family .....	25
P08: Plants make me spiral.....	32
P09: Romance of the Three Kingdoms .....	37
P10: This is a BLAST.....	39
P11: Hold Dear to Me.....	43
P12: How should I choose my flowers? .....	48
P13: Don't cry over spilt milk, EMMA! .....	54
P14: Hereditary Cancer .....	58
P15: Golden Apple Archipelago .....	61
P16: Malicious Malicia's Malaria Magnum Opus I.....	68
P17: This problem is a bully .....	73
P18: Training in the Avidya Forest.....	75
P19: Malicious Malicia's Malaria Magnum Opus II.....	82
P20: Daddy Long Legs .....	85
P21: Trihybrid Trouble .....	88
P22: Bend it like Bee-ckham .....	92
P23: It's time for a face lift I.....	100
P24: The Dancing Queen.....	104
P25: Potato Disease.....	108
P26: Abs .....	112
P27: It's time for a face lift II.....	115
P28: X marks the spot.....	118
P29: Y2H? Y2K?.....	121



P30: The Animal Kingdom.....	126
P31: Vanda Miss Joaquim .....	131
P32: Emma is crying again! .....	134
P33: Despicable Me .....	138
P34: Character Displacement .....	142
P35: Replication: A Closer Look .....	145
P36: T6 .....	150
P37: More Abs .....	157
P38: $U + I < 3$ .....	162
P39: Heat. Cool. Multiply.....	167
P40: Anaemia.....	170

# P01: Belobog Camping Trip

(160 points)

Welcome to Belobog, the last bastion of the planet Jarilo-VI. 700 years ago, a phenomenon known as the Eternal Freeze enveloped the entire planet in blistering ice. The once-green and bountiful ecology was buried in a snowy grave, and most of the human population with it. Only the city of Belobog survived the disaster, but...

*“...but despite having to weather the harsh climate, humanity persevered and lived to see the sunrise again!”* She smiles as she hands you a tuna sandwich (Figure 1). *“Well, all that’s history now. After you and your gang managed to conquer the Eternal Freeze, the global climate is slowly but surely returning back to normal!”*



Figure 1: A tuna sandwich.

That’s right. You and your gang managed to conquer the Eternal Freeze with your determination, perseverance, and plot armour. You grin in pride as you bite into the tuna sandwich (Figure 1).

Oh yeah, that’s Lynx. She’s a camping and ecology enthusiast that you had met while you were journeying through Belobog. The two of you are on a camping trip in the middle of nowhere to study the soon-to-be-blossoming ecology.

*“So, ready to head out?”* She reaches out for your hand to pull you up from your comfortable camping chair. You remind yourself that this is not a date. *“Let’s go~”*

---

## Day 1: Animal spotting

*Dear diary, I am actually bored to death and I am only here to spend time with Ly-*

*“Hey!” Lynx interrupts your inner monologue as she throws you a pair of binoculars. “Look at that!”*

**Q1.** Through the binoculars, you spot several interactions between living things. Match each observation with the name of the corresponding biological interaction (A-G) between the underlined species. **(40 points)**

*(Match the correct letter to the correct row.)*

- A. Predation
- B. Mutualism
- C. Commensalism
- D. Parasitism
- E. Amensalism
- F. Competition
- G. Neutralism

Observation	Interaction (A-G)
A <u>lion</u> and a <u>hyena</u> are practically wrestling for a dead horse on the ground. Is there a point in beating a dead horse?	
A <u>bee</u> collects nectar from a <u>flower</u> . How sweet! Well, literally.	
A <u>cow</u> walks through the field, crushing the poor, poor <u>grasshoppers</u> that live in the grass. Bummer.	
The same <u>cow</u> grazes the field, exposing the very dead grasshoppers to the <u>birds</u> holding a flyer that reads “Grasshopper Buffet (Courtesy of Cow.)”	

*“Wow! Staring at these animals and how they interact... ah~ I love ecology.” Lynx says unironically. “Isn’t this so fun?”*

You cannot help but nod as Lynx passes you a tuna sandwich (Figure 1).

## Day 2: More animal spotting

*Dear diary, turns out I REALLY hate camping but Lynx is honestly so nice to m-*

*“Oh, wow! What a cute rabb-”* Lynx interrupts your train of thoughts, before she herself was interrupted by an unfortunate incident involving a fox. *“Never mind, what a mutilated rabbit.”*

Suddenly, Lynx grabs your hand and pulls you towards a bush. *“Shh! Here, take these binoculars again.”*

Both of you stare at animals for hours before Lynx draws up a food web based on your observations. How romantic.

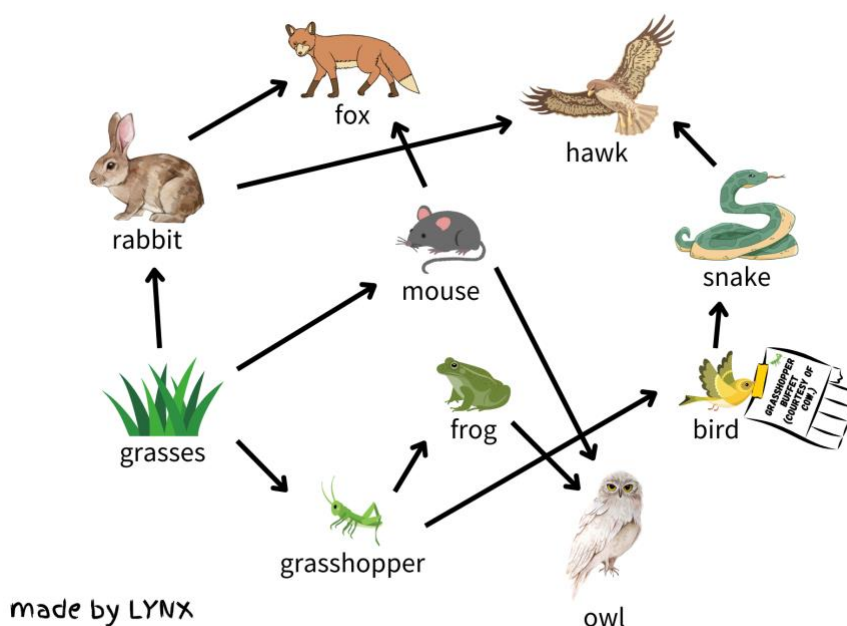

Figure 2: A food web designed by Lynx.

**Q2.** With reference to Figure 2, select all the secondary consumers from the list below. **(50 points)**  
*(Select all correct options.)*

- A. Fox
- B. Hawk
- C. Rabbit
- D. Mouse
- E. Snake
- F. Grasses
- G. Frog
- H. Bird
- I. Grasshopper
- J. Owl



You are sad because you have watched many animals die in the course of several hours. You have developed a newfound resolve to solve such ecological injustice! You take out your handheld Death Note and prepare to write down the names of the apex predators. They must pay for their wrongdoings!

**Q3.** Using the first letter of the common names of the species as shown in Figure 2 (e.g. “C” for cat), order the apex predators by their trophic levels from lowest to highest. For example, if you think the answer is “Cat (lowest), Dog, Elephant (highest)”, type “CDE”. **(30 points)**  
(Enter a string of letters.)

**Q4.** State the number of trophic levels in the longest food chain. **(10 points)**  
(Enter a whole number.)

Turns out your handheld Death Note was a dud. The guy at the marketplace must have been a swindler! With a sigh of disappointment and resignation of your previously newfound resolve, you reach into Lynx’s pocket and grab a tuna sandwich (Figure 1).

---

### **Day 3: More animal spottin— ah crud, we’re lost in a forest**

*Dear diary, we have been walking for two months. We are out of water, food and lov-*

*“Huh.”* Lynx suddenly says. *“We are no longer in a snowy biome. Where on earth are we?”*

Suddenly, someone appears from the shadow. He looks like a cross between a human and a fennet. The human fennet suddenly opens his mouth. *“Oh, hey there travellers! I’m Tighnari, a researcher in the Avidya Forest which you are standing on right now!”*

Avidya Forest?! You are so surprised at the fact for some reason that you retreat to the top of a tree.

*“Huh. We must have been walking for so long we crossed into a whole different game- ah wait, breaking the fourth wall isn’t allowed here!”* Lynx says as she stares into a camera.

You have retreated to the top of a tree. It is safe, cozy, comfy, and absolutely perfect for some rest. Wait, no. You don’t know how to get down. You scream for help.

*“Ah, don’t worry. Here, have some diagrams I drew just now. Maybe do some science while I come save you.”* Lynx says as she throws a crumpled piece of paper (Figure 3) at you.

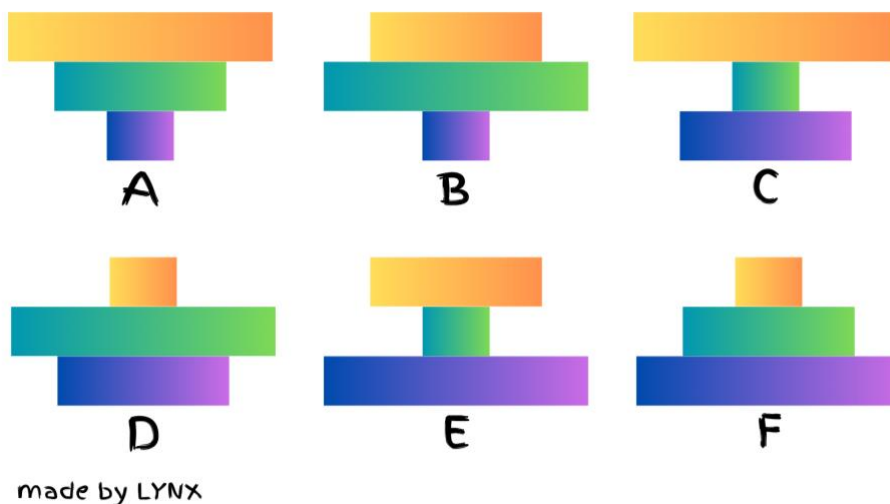

Figure 3: Several pyramids (labelled A to F) that Lynx drew on paper.

**Q5.** You are stuck on top of a tree. Lynx is climbing the tree to try and save you. Meanwhile, you stare at a ladybug happily munching on a leaf from the tree. It fills you with determination. Unfortunately, a bird holding a flyer that reads “*Grasshopper Buffet (Courtesy of Cow.)*” is illiterate and eats the ladybug instead. For this particular food chain in the entire Avidya Forest, state the pyramid in Figure 3 (A-F) that most likely matches the pyramids of numbers, biomass, and energy respectively. **(30 points)**

*(Enter the correct letter to the correct row.)*

tree → ladybug → bird	
Pyramid	A-F
Pyramid of numbers	
Pyramid of biomass	
Pyramid of energy	

Hurray. You are saved by Lynx. You thank her profusely.

“Oh, don’t worry about it! Shall we call it a day?” Lynx says while you both sit on a tree branch. “Well, I’m a little hungry. How about a snack?”

Lynx pulls out a tuna sandwich (Figure 1) for herself and a tuna sandwich (Figure 1) for you. You finish the tuna sandwich (Figure 1) in two bites. Then, the two of you decide to call it a day and take a Teleport Waypoint back to Belobog City. What an adventure!





Figure 4: Alternative photo of a tuna sandwich that cannot be referenced as this figure is all the way at the bottom of the problem.

# P02: Ramachandran Plots

(110 points)

In their 1963 paper titled “*Stereochemistry of polypeptide chain configurations*”, G. N. Ramachandran, C. Ramakrishnan, and V. Sasisekharan developed the Ramachandran plot. A Ramachandran plot is a way to visualise energetically-allowed regions for backbone dihedral angles  $\Psi$  (psi) against  $\phi$  (phi) of amino acid residues in a protein structure. This is because atoms of the polypeptide can rotate about the N-C bond ( $\Psi$  angle) and the C-C bond ( $\phi$  angle).

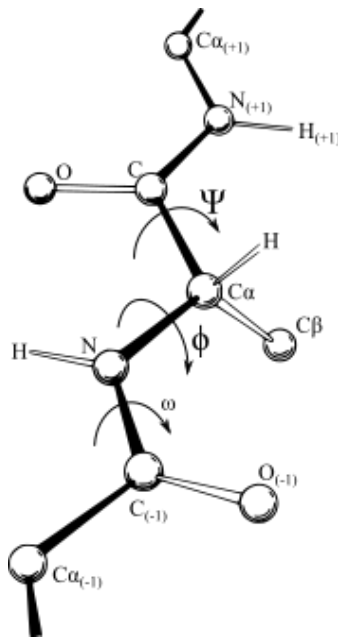

Figure 1: Backbone dihedral angles  $\Psi$  (psi) against  $\phi$  (phi)

Figure 2 shows three Ramachandran plots. The blue area represents favourable dihedral angles while the green area represents allowed, but unfavourable dihedral angles. A larger shaded area indicates that the amino acid has a wider range and greater number of combinations of dihedral angles allowed, due to less steric repulsion between the neighbouring atoms.

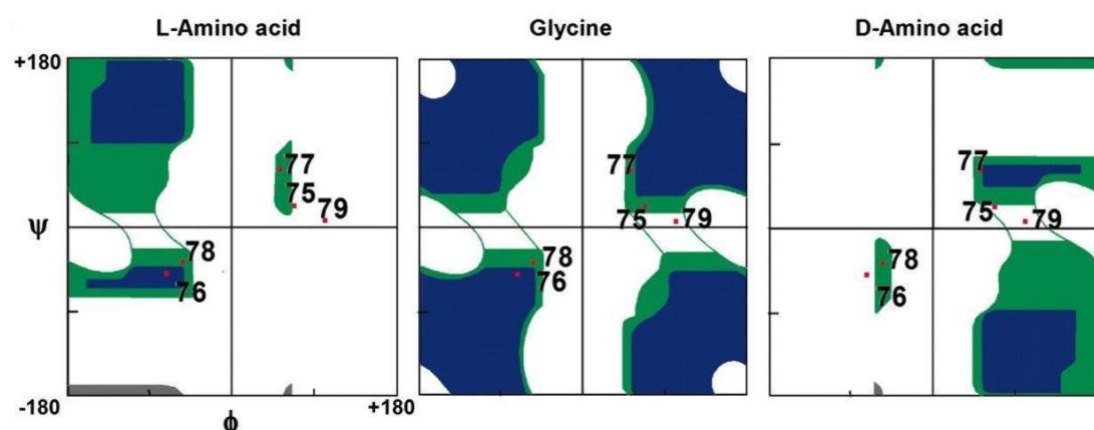

Figure 2: Ramachandran plot

**Q1.** By observing Figure 2 and considering the structure of glycine, indicate which statement most accurately describes the resemblance of the Ramachandran plot of glycine to that of a random L-amino acid and a random D-amino acid. **(10 points)**

*(Select the correct option.)*

- A. The Ramachandran plot of glycine resembles that of L-amino acid more than that of D-amino acid.
- B. The Ramachandran plot of glycine resembles that of D-amino acid more than that of L-amino acid.
- C. The Ramachandran plot of glycine resembles that of L-amino acid as much as that of D-amino acid.
- D. Glycine does not have a Ramachandran plot.
- E. Glycine has an infinite number of possible Ramachandran plots.

**Q2.** By considering their structures, indicate which one of the following amino acids will likely have the greatest coloured region on the Ramachandran plot. **(10 points)**

*(Select the correct option.)*

- A. Arginine
- B. Alanine
- C. Asparagine
- D. Cysteine
- E. Glutamic acid
- F. Glycine
- G. Histidine
- H. Isoleucine
- I. Leucine
- J. Tyrosine

Since amino acids also contain a strongly acidic carboxyl group as well as an amino group, they can be titrated against an alkali. The titration curves of all 20 canonical amino acids are seen in Figure 3.

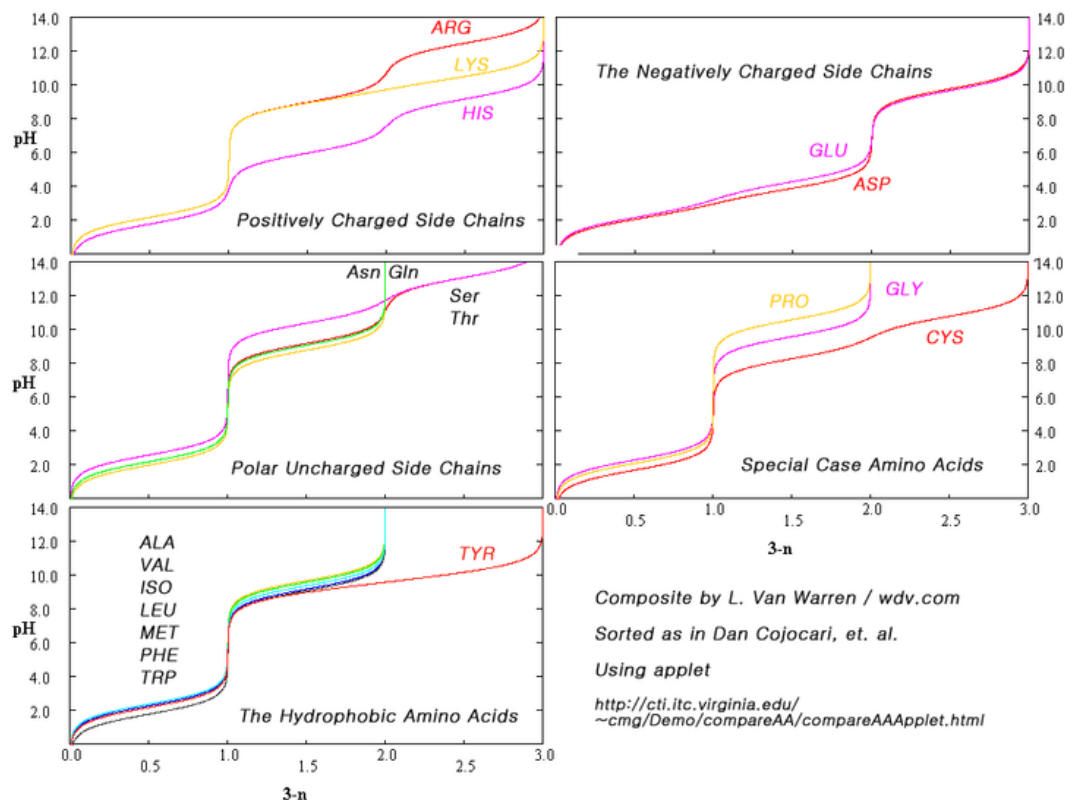

Figure 3: Titration Curves of the 20 canonical amino acids

**Q3.** What is the minimum number of pH buffering zones for any amino acid? **(10 points)**

(Enter a whole number.)

**Q4.** Indicate whether the following statements are true or false with reference to the data and graph provided above. **(40 points)**

(Mark each statement as true or false.)

- Possible combinations of favourable dihedral angles may be larger than that of allowed dihedral angles.
- Only the amino acids with positively-charged side chains or negatively-charged side chains can react with HCl or NaOH.
- 1 mole of NaOH will react with 1 mole of neutral tyrosine.
- In neutral zwitterionic lysine, the  $\alpha$ -NH<sub>2</sub> group is positively charged and exists as -NH<sub>3</sub><sup>+</sup>.



Other than the carboxyl and amino groups, amino acids also contain R-groups. The R-groups of amino acids are responsible for the determination of the chemical and conformational properties of a protein.

**Q5.** Match the following properties to the possible amino acid(s) that can have the property. The number of possible amino acids has been provided for you in the table. **(40 points)**

*(Give the one-letter amino acid code. If there is more than one possible amino acid, give the codes in alphabetical order. For example, if the answer is glycine and alanine, enter AG.)*

<b>Property</b>	<b>Amino Acid(s)</b>
Allows the resultant protein to have a high optimum temperature and temperature of denaturation <i>(only 1 possible amino acid)</i>	
Allows the formation of a tight triple helix by fitting into the tight restricted space <i>(only 1 possible amino acid)</i>	
Relatively high proportion in histones, allowing histones to form electrostatic attraction with negatively-charged DNA. <i>(only 3 possible amino acids)</i>	
Phosphorylation of this amino acid in insulin receptors is responsible for the initiation of a phosphorylation cascade <i>(only 1 possible amino acid)</i>	

# P03: Family Guy

(200 points)

Contraceptives are methods employed to prevent pregnancies. One form of contraceptives are oral contraceptive pills for females which contain progestin and oestrogen to prevent pregnancy. While there are currently no male contraceptive pills, scientists are experimenting with a hormone-based pill called dimethandrolone undecanoate (DMAU) which was determined to be safe in a small study in 2019. This pill is shown as “E” in Figure 1. Figure 1 shows four other possible contraceptives.

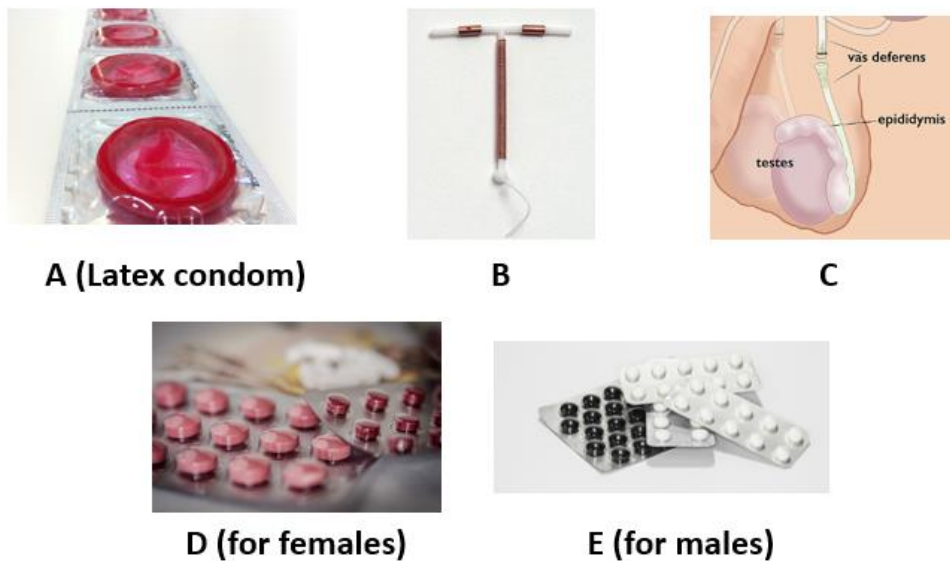

Figure 1: Possible contraceptives

You are a fertility doctor and five couples have come to you as they each need help with choosing the correct contraception. You take their history and future intentions in the table below.

Couple (F and M)	Scenario
Alice and Bernard	Bernard has Gonorrhoea while Alice has Syphilis. They are sure they do not want children.
Carol and Denver	A couple who recently got married. Wishes to have regular sexual intercourse for the first two years before settling down and having their own children.
Esther and Felix	A young couple who is pretty sure they do not want children. Esther has trouble consuming pills, and Felix is terrified of procedures and will not consent to any.
Giselle and Hector	An old couple who has had four children before and is sure they no longer want to have any more children.
Isabella and Joel	Isabella is allergic to latex, but Joel is not. Isabella has Wilson’s disease (copper accumulation in liver) but always forgets to take her medicine. They are hoping to try for a child next year when they get a BTO flat.

**Q1.** You need to help match the most appropriate contraceptive method to each couple, assuming you may only use each option (A-E) once and that DMAU is available on trial to all couples and all five couples are willing to try it. **(50 points)**

*(Match the correct letter to the correct row.)*

Couple	Most appropriate contraceptive (A-E)
Alice and Bernard	
Carol and Denver	
Esther and Felix	
Giselle and Hector	
Isabella and Joel	

Another contraceptive method is the rhythm method, which makes use of the menstrual cycle to predict when the female is most fertile and to avoid sexual intercourse during then. After ejaculation, sperm remains viable in the vaginal tract for up to five days and eggs remain viable for up to 24 hours after ovulation. This forms the fertile period, during which fertilisation and hence implantation can occur.

Kimberly and Luis wish to make use of this natural contraceptive to avoid getting pregnant. Kimberly has been tracking her period for the last two months and has taken note of her last periods in the calendar below.

Week	M	T	W	T	F	S	S
<b>2024 June</b>							
<b>Week 22</b>						1	2
<b>Week 23</b>	3	4	5	6	7	8	9
<b>Week 24</b>	10	11	12	13	14	15	16
<b>Week 25</b>	17	18	19	20	21	22	23
<b>Week 26</b>	24	25	26	27	28	29	30
<b>2024 July</b>							
<b>Week 27</b>	1	2	3	4	5	6	7
<b>Week 28</b>	8	9	10	11	12	13	14
<b>Week 29</b>	15	16	17	18	19	20	21
<b>Week 30</b>	22	23	24	25	26	27	28
<b>Week 31</b>	29	30	31				
<b>2024 Aug</b>							
<b>Week 32</b>				1	2	3	4
<b>Week 33</b>	5	6	7	8	9	10	11
<b>Week 34</b>	12	13	14	15	16	17	18
<b>Week 35</b>	19	20	21	22	23	24	25
<b>Week 36</b>	26	27	28	29	30		

Legend: Red: Start of period | Yellow: National Day | Green: SBL Day



**Q2.** Assuming that Kimberly has a consistent 26-day menstrual cycle with ovulation occurring on Day 13, and considering the fertile period of Kimberly, answer the following questions. Also assume that ejaculation and ovulation occur at 0000hrs of the respective days. **(30 points)**  
(Enter a number to each row.)

Question	Answer
When will Kimberly experience her first period in 2024 August? (Leave your answer as DDMMYYYY.)	
On which day should Kimberly and Luis stop having sexual intercourse in 2024 August? (Leave your answer as DD.)	
On which day can Kimberly and Luis resume having sexual intercourse in 2024 August? (Leave your answer as DD.)	

In female mammals of the subclass Theria, they do not have menstrual cycles but instead have oestrous cycles. Monoestrous species like bears only have one oestrous cycle per year, while polyoestrous species like cats have multiple oestrous cycles per year.

A distinction between the oestrous and menstrual cycle is that animals that have oestrous cycles reabsorb the endometrium if conception does not occur, in contrast to those with menstrual cycles who shed theirs via menstruation. After conception, some animals also eat their own placenta.

Unlike humans, most other species do not have menopause. Menopause is referred to as the cessation of ovulation and menstruation. After menopause, the female is no longer able to conceive and reproduce.

**Q3.** Based on the given preamble, indicate whether the following statements are true or false. **(40 points)**

(Mark each statement as true or false.)

- Monoestrous species likely lack progesterone and oestrogen while polyoestrous species likely contain progesterone and oestrogen.
- A possible evolutionary benefit of monoestrous species is that they can be pregnant more frequently than species with a monthly menstrual cycle.
- A possible evolutionary benefit of eating the placenta is to prevent signalling to predators that there has been a recent birth.
- Menopause may have evolved in humans to allow a mother to stop bearing so that she can focus on taking care of her children.



Monica is a zookeeper at a zoo and needs to predict the best time to let Animal X mate. Figure 2 shows the seasonal levels of oestrogen and progesterone in Animal X. Animal X is known to be a monoestrous species.

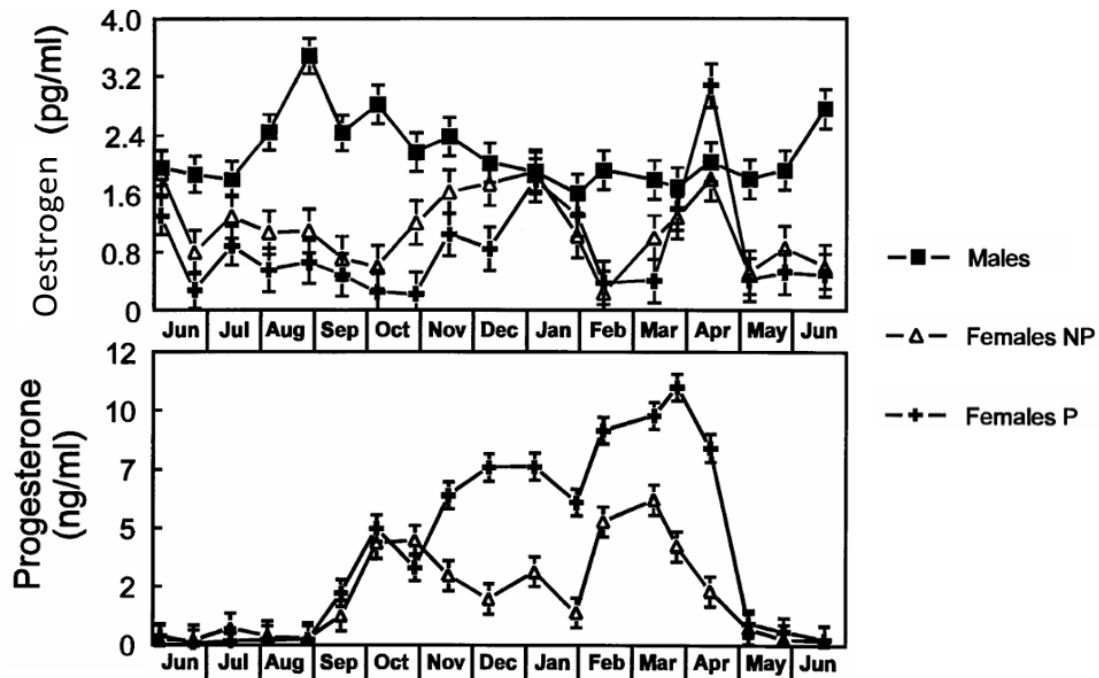

Figure 2: Seasonal changes of oestrogen and progesterone in animal X.  
NP: not pregnant; P: pregnant

**Q4.** By comparing the changes in the graphs with that of a human female and the time of ovulation, which of the following months is the best time to let animal X mate? **(20 points)**  
(Select the correct option.)

- A. January
- B. April
- C. July
- D. November

Different species of animals have also evolved different forms of mating unlike that of humans.

- During copulation, the male honeybee’s penis explodes in the female’s vaginal tract. While the male subsequently dies, the exploded penis plugs and blocks the vaginal tract.
- Some male ducks have corkscrew-shaped penises and female ducks have vaginas that spiral in the opposite direction. During mating, the penis is inserted all the way to the end of the spiral vaginal tract, and semen is released.
- After sexual intercourse, female praying mantis often chew off the head of the male praying mantis, killing the praying mantis.

**Q5.** Based on the given preamble, indicate whether the following statements are true or false. **(40 points)**

*(Mark each statement as true or false.)*

- A. A possible evolutionary benefit of honeybee's exploding penises is it prevents other males from mating with the female bee.
- B. A possible evolutionary benefit of corkscrew-shaped penises and vaginas in ducks is that sperm will need to swim through the spiral vaginal tract to reach the eggs. Hence, stronger sperms are more likely to reach the egg faster and are selected for.
- C. A possible evolutionary benefit of praying mantis eating their mate is that it prevents the male from mating with other females.
- D. Male honeybees and male praying mantises likely can only mate once in their lifetime.

Oogenesis, the production of oocytes, starts in the female embryo. Primordial germ cells divide to form oogonia, which then develop to form primary oocytes. Human females are thus born with oocytes in her ovaries. During birth, she has about 1 to 2 million primary oocytes, while at puberty, she has about 300 000 oocytes. However, not all oocytes mature to become eggs. Approximately 500 oocytes fully mature between puberty and menopause, and one oocyte is released approximately every month during ovulation. Before the eggs are released, the follicles need to mature. They increase in size and swell, and they burst open during ovulation releasing one egg. After all eggs have been released over many years, menopause occurs. Menopause is defined as 12 months after a female's last period. Hence, the female is no longer able to be pregnant.

**Q6.** Naomi is a female with a perfect 1-month menstrual cycle and has exactly 200 oocytes which will be matured in **each** of her ovaries. She started menarche (first period) immediately after she turned age 12 and got pregnant twice. Assuming her menstrual cycle returned exactly 2 months after delivery of each of her children, calculate at which age she will reach menopause. **Round up** to the nearest whole number. **(20 points)**

*(Leave your answer rounded up to the nearest whole number.)*

# P04: Feathers and Mr. Birdy

(100 points)

Most bird species dislike wind and rain conditions and often migrate to other warmer areas during winter. According to National Geographic, approximately 40% of the birds in the world migrate to warmer areas which have more food. With Singapore's warm weather all year round, Singapore is a hotspot for many of these birds.

Bird Paradise was opened on 8 May 2023 which replaced the Jurong Bird Park as an aviary in Singapore. As a cytogeneticist working there, you are investigating a case of aneuploidy in one of the birds called Feathers. The normal karyotype of a bird from the same species is seen in Figure 1.

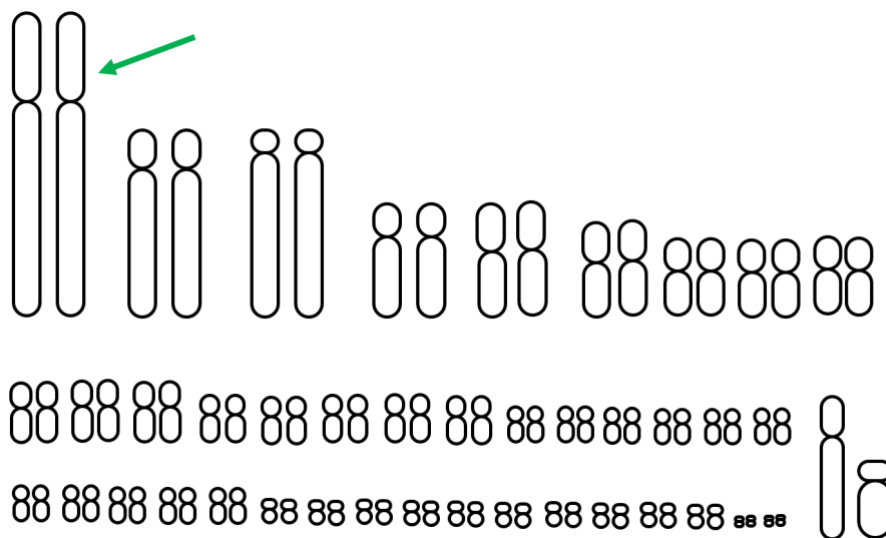

Figure 1: Normal Karyotype of species of Feathers. The green arrow indicates Chromosome 1.

**Q1.** Indicate whether the following statements regarding this species are true or false. (40 points)  
(Mark each statement as true or false.)

- A. This karyotype could have been taken during metaphase of mitosis using colchicine.
- B. Chromosome 1 is telocentric.
- C. The karyotype was likely taken from a male.
- D. The normal gamete of this species will contain 40 autosomal chromosomes.

Feathers has a trisomy of chromosome 1. This implies that at least one gamete had mutations. Figure 2 shows the staining pattern of chromosome 1 for Feathers and its parents.

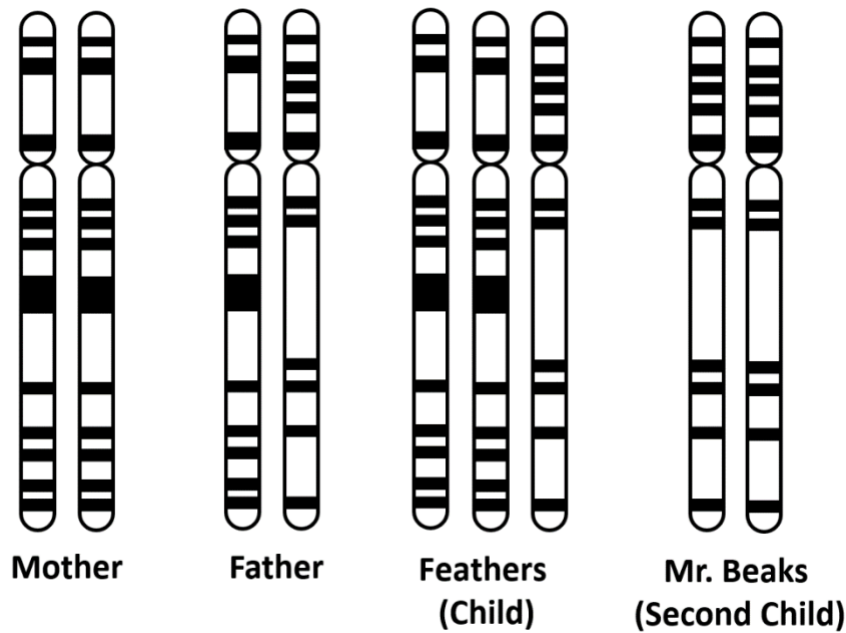

Figure 2: Staining pattern of chromosome 1 of Feathers, Mr. Beaks and their parents

**Q2.** Which of the following **could not** have happened during gametogenesis to give rise to Feather's trisomy 1? **(30 points)**

*(Select all correct options.)*

- A. Non-disjunction during Meiosis I during spermatogenesis.
- B. Non-disjunction during Meiosis II during spermatogenesis.
- C. Non-disjunction during Meiosis I during oogenesis.
- D. Non-disjunction during Meiosis II during oogenesis.

Mr. Beaks is Feathers's younger brother from the same parents. As a cytogeneticist, you noticed that the staining pattern of chromosome 1 of Mr. Beaks is unusual. You hypothesised that it may have arisen due to non-disjunction during gametogenesis.

**Q3.** Which of the following **could not** have happened during gametogenesis to give rise to Mr. Beaks' chromosome 1 staining pattern? **(30 points)**

*(Select all correct options.)*

- A. Non-disjunction during Meiosis I during spermatogenesis.
- B. Non-disjunction during Meiosis II during spermatogenesis.
- C. Non-disjunction during Meiosis I during oogenesis.
- D. Non-disjunction during Meiosis II during oogenesis.

# P05: Gummyfish

(100 points)

Gummyfishes used to thrive in aquatic environments several years ago. As its population rose dramatically and resources in the water depleted, some individuals eventually evolved to move to land, where there would be less competition.

**Q1.** Several traits have been identified in various present-day descendants of gummyfishes found in aquatic and terrestrial environments. These traits may have different benefits for the gummyfishes. Match each trait to how it benefits the gummyfishes on land using the numbers 1-

**4. (60 points)**

*(Enter a number to each row.)*

1. Aids respiration on land
2. Aids movement on land
3. Other benefit on land
4. No benefit on land

Trait	Benefit (1-4)
Nostrils	
High refractive index of lens	
Moist skin	
Presence of extraembryonic membranes	
Connection of pelvis to ribs	
Broad and flattened limbs	

Due to the stark differences in adaptations necessary to thrive on land as opposed to water, the transition from a fully aquatic species to a fully terrestrial one cannot occur directly without an intermediate state, which is semiaquatic. The interconversion between the semiaquatic state with either the terrestrial or aquatic state is considered as **one** distinct evolutionary event. Figure 1 shows a phylogenetic tree of the descendants of gummyfishes.

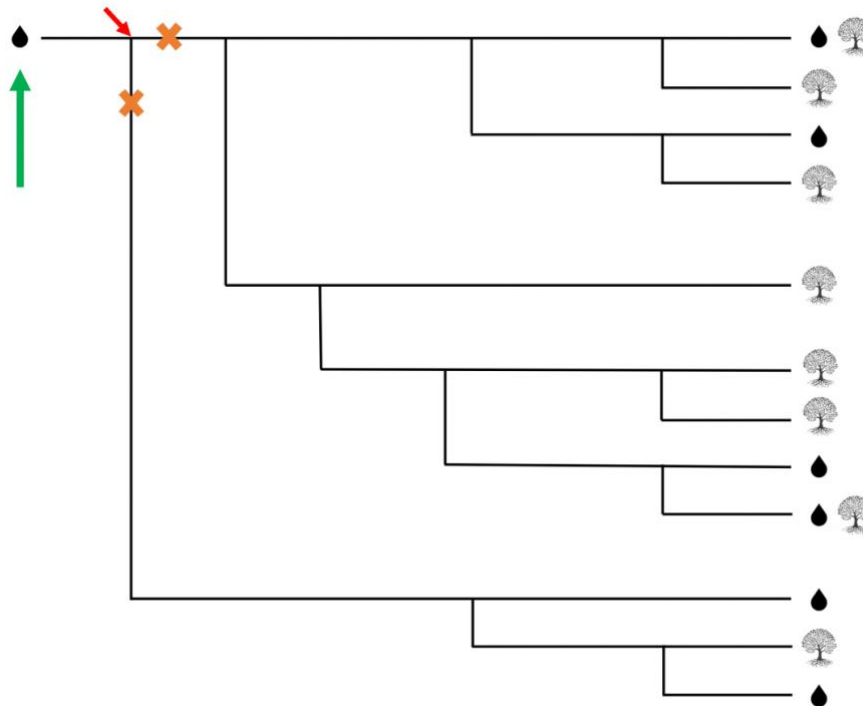

Figure 1: Phylogenetic tree of the descendants of gummyfishes. Water droplets indicate fully aquatic species, trees indicate fully terrestrial species, and the presence of both symbols indicate semiaquatic species.

The ancestor of all the descendants is marked by the green arrow. This ancestor is a fully aquatic species. Over long periods of time, mutations can accumulate in the genome of the ancestors which changes the habitat type of the species. However, mutations are rare so such changes do not occur very frequently.

At the node indicated by the red arrow, the tree splits into two. If no changes in habitat type had occurred before this node, then the ancestors that go into the two lineages will still have the same habitat type, as seen by the orange crosses.

We can see that there are several changes in the habitat type of the descendants. We would like to see what the minimum number of changes in habitat type is that could have occurred to give rise to this phylogenetic tree. Such a tree is called the most parsimonious phylogenetic tree.

Occam's razor is a principle used in phylogenetics to find the most parsimonious phylogenetic tree. Occam's razor states that if hypotheses have equal explanatory powers, the one requiring the fewest assumptions should be the preferred hypothesis. Hence, with all other things being equal, the



phylogenetic tree which requires the fewest number of changes in habitat types is the best hypothesis and can be used as the most parsimonious tree.

Using the tree in Figure 1, consider at which points of the tree changes in habitat types could have occurred. Remember that any change in the habitat type would mean that all descendants from that ancestor will have that new habitat type, unless another change occurred to change the habitat type.

**Q2.** What is the minimum number of evolutionary events required to account for the phylogenetic tree presented? Note that fully aquatic, semiaquatic, and fully terrestrial habitats are considered distinct habitats. **(30 points)**

*(Enter your answer as a whole number.)*

**Q3.** Which term correctly describes the group formed by all the fully aquatic species? **(10 points)**

*(Select the correct option.)*

- A. Monophyletic
- B. Paraphyletic
- C. Polyphyletic
- D. None of the above

# P06: Modifications

(120 points)

A method of transcriptional regulation is the formation of euchromatin and heterochromatin. The DNA in cells is present in the form of chromatin. Loosely-packed chromatin is called euchromatin, while tightly-wound chromatin around histones is called heterochromatin. Being more tightly packed, heterochromatin is less exposed and hence less accessible to the action of transcription by DNA polymerases.

Figure 1 shows the ultrastructure of a cell.

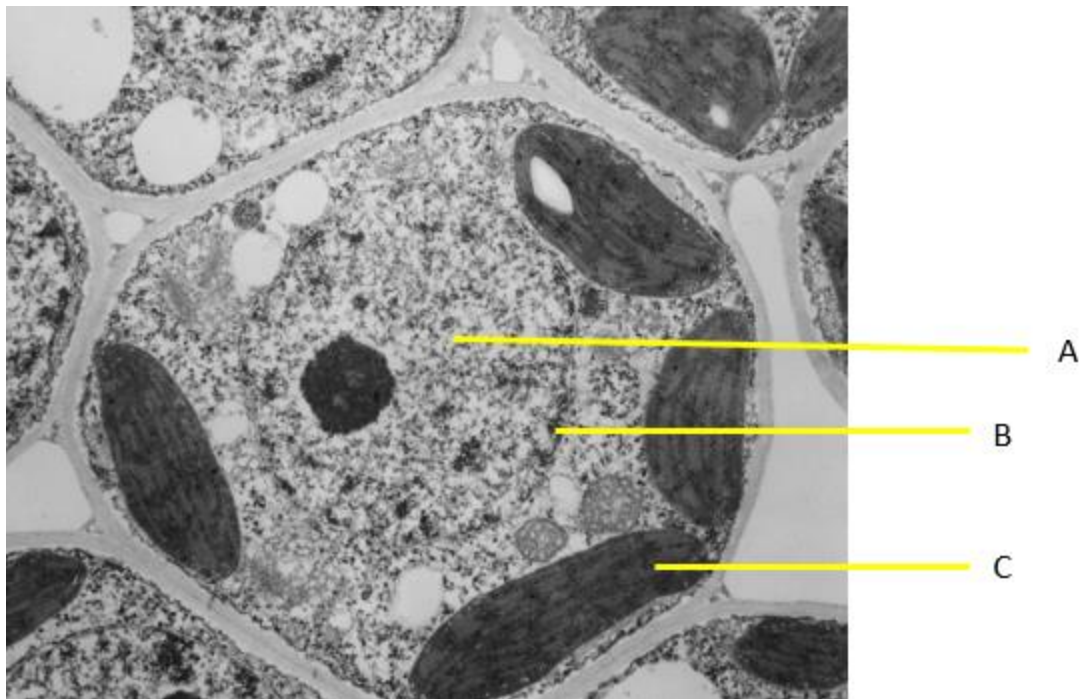

Figure 1: Ultrastructure of cell

It has been determined that either gene D or E is transcriptionally active in the cell in Figure 1. To determine which gene is transcriptionally active and hence the DNA is less tightly wound, you perform an experiment. You extracted the DNA from the cell and treated them with a non-specific endonuclease. Such an endonuclease breaks the phosphodiester bonds randomly in the DNA hence cleaving the phosphate backbone into two. Hence, there is a chance that the endonuclease will cleave the gene, preventing probes from being able to bind to it. **The entire sequence of the gene must be intact for the antibodies to bind to it.**

You then isolated the cleaved DNA and incubated them with an excess of radioactive probes specific for a 20-nucleotide long sequence in either gene D or gene E. The results are seen in Figure 2.



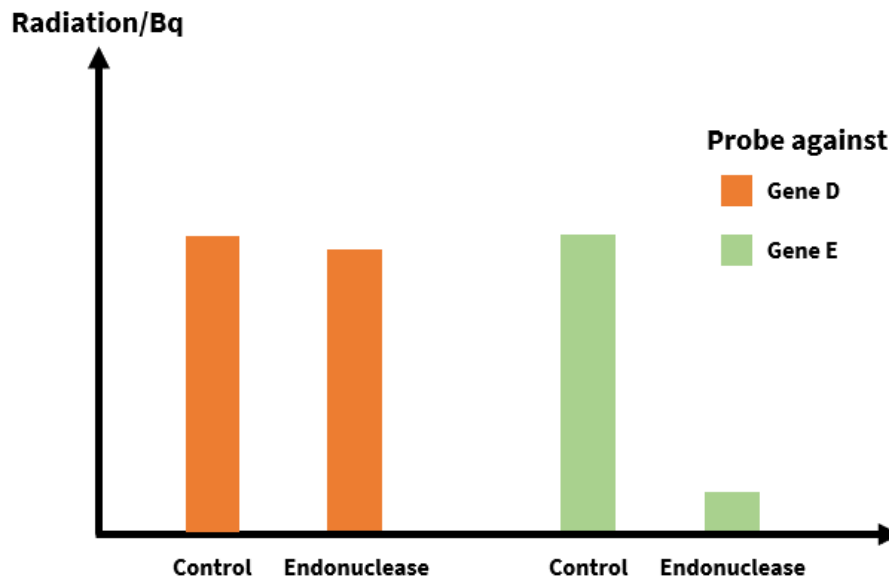

Figure 2: Radiation after incubation with probes specific to different genes. Control: Absence of endonuclease. Endonuclease: Presence of endonuclease. Endonuclease was removed before addition of probes.

**Q1.** Indicate whether the following statements are true or false. **(40 points)**  
*(Mark each statement as true or false.)*

- The cell in Figure 1 is a plant cell.
- Structure A is heterochromatin and Structure B is euchromatin.
- Structure C is the mitochondria.
- Gene D is transcriptionally active in the cell.

Another form of modification occurs after the polypeptide chain is synthesised. Post-translational modifications occur to prepare the protein for its functional role in or out of the cell. Figure 3 shows three examples of post-translational modification-regulation of RNA-binding proteins.

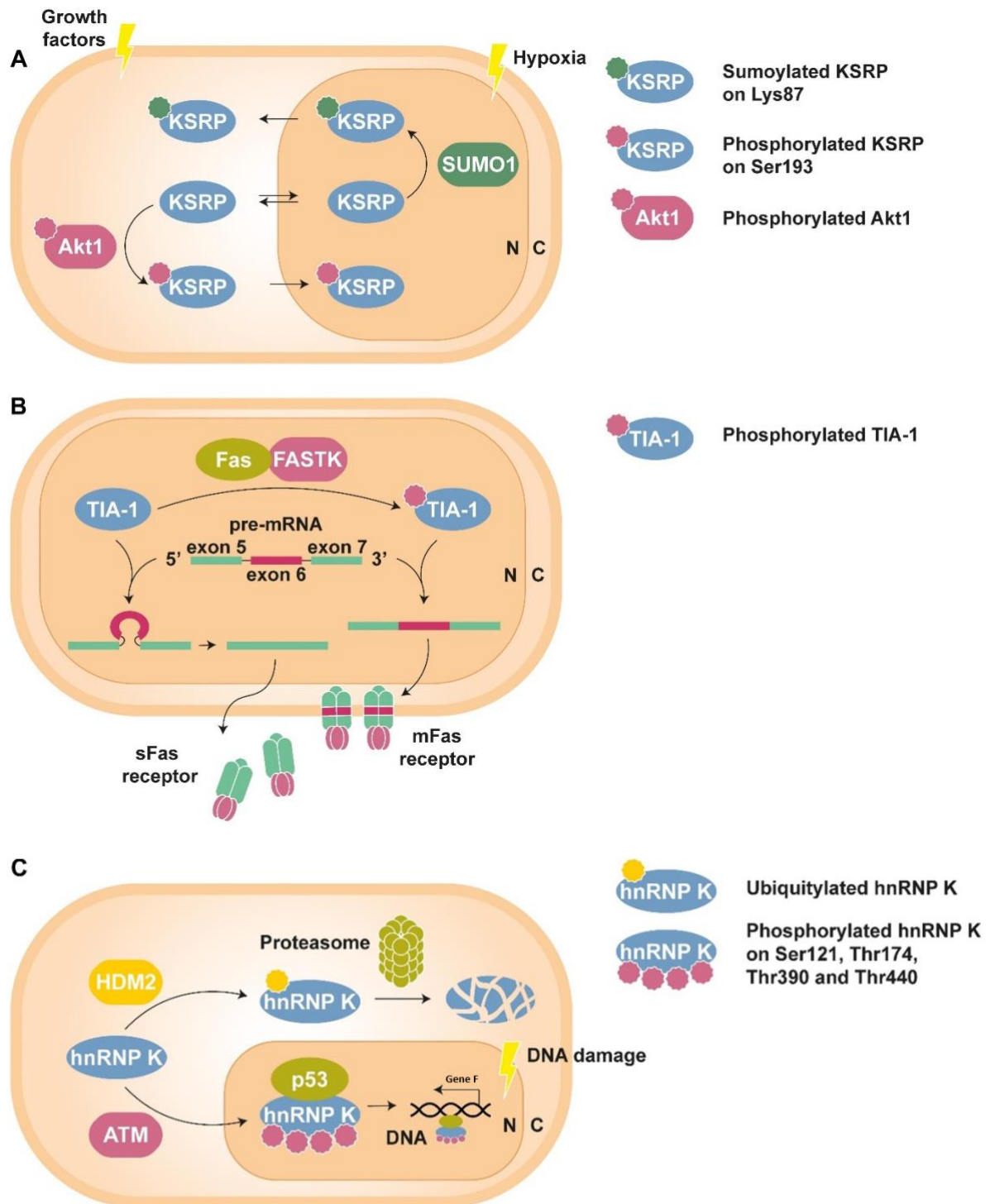

Figure 3: Post-translational modification-regulation of RNA-binding. N: Nucleus. C: Cytoplasm. Lightning symbols indicate the conditions that will stimulate such a pathway in the cell. (A) KSRP and SUMO1 each perform specific functions in the nucleus and the cytoplasm. (B) mFas plays an important role in extrinsic apoptosis signalling pathways, while sFas blocks apoptosis. (C) hnRNP K binds to HDM2 under standard conditions.

**Q2.** Indicate whether the following statements are true or false. **(40 points)**

*(Mark each statement as true or false.)*

- A. KSRP is able to diffuse freely via simple diffusion from the nucleus to the cytoplasm and back.
- B. Phosphorylated KSRP may upregulate genes involved in growth.
- C. Figure 3B shows alternative splicing.
- D. The translated region of exon 6 in figure 3B likely contains many amino acid residues with hydrophilic R-groups.

**Q3.** Indicate whether the following statements are true or false. **(40 points)**

*(Mark each statement as true or false.)*

- A. Phosphorylation of TIA-1 by FASTK is likely overactive in cancer cells.
- B. Ubiquitylation of hnRNP K is required for its degradation by the proteasome.
- C. hnRNP K usually binds to p53 under standard conditions.
- D. In cancer cells, there is more likely a gain-of-function mutation than a loss-of-function mutation in gene F.

# P07: The Squarepants Extended Family

(160 points)

Generally speaking, sponges (phylum Porifera) are considered the simplest of animals. Unlike other animals, they do not have separate germ layers and do not have any true tissues. Most, although not all, sponges are also asymmetrical, while most other animals possess radial symmetry or bilateral symmetry.

The following are examples of asymmetry and two types of symmetry.

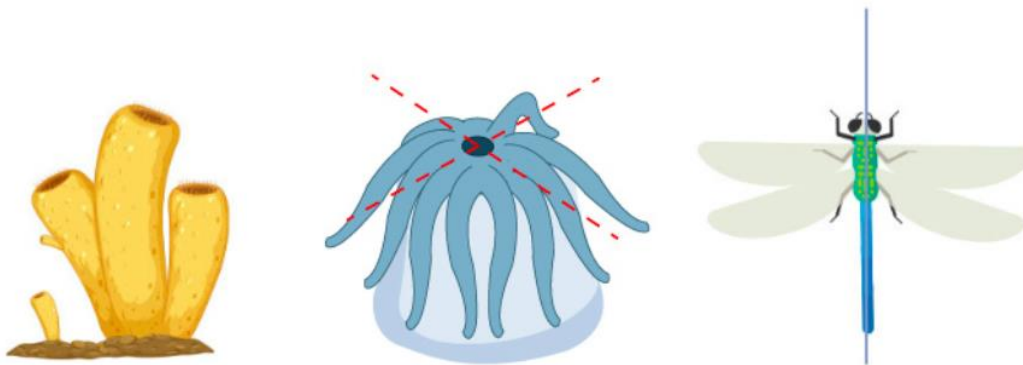

A: Asymmetry

B: Radial symmetry

C: Bilateral symmetry

Figure 1: Examples of symmetry types

In Figure 1, Animal A has **no symmetry** or **is asymmetrical**.

Animal B is **radially symmetrical** because it has many different planes of symmetry, which can divide the body into many (roughly) equal parts around a centre from the top-down view. Two specific types of radial symmetry include **biradial symmetry** (commonly exhibited by ctenophores) and **pentaradial symmetry** (commonly exhibited by echinoderms), which means that the body can be divided into two and five equal parts around a centre from the top-down view respectively.

Animal C is **bilaterally symmetrical** because it has one plane of symmetry dividing the body into two (roughly) equal parts.

Figure 2 shows several animals with different types of symmetry.

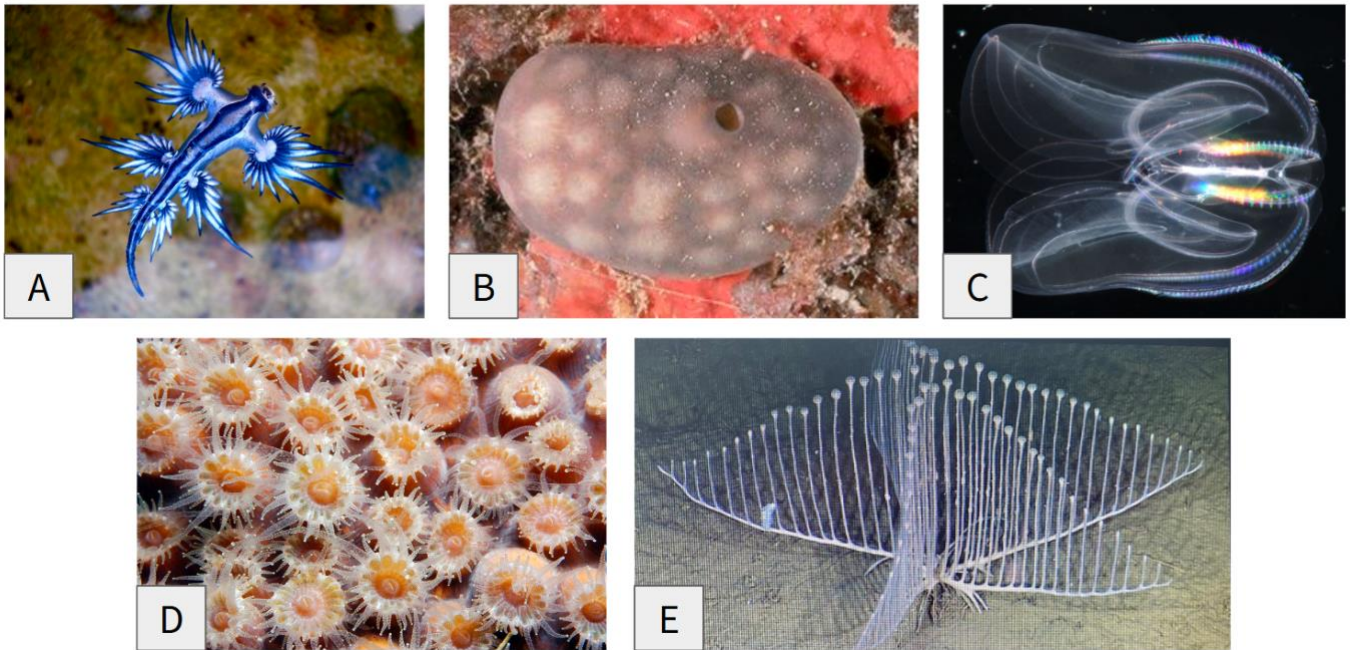

Figure 2: Various sea creatures

**Q1.** Match the animals to their respective type of symmetry. Each type of symmetry will only correspond to one letter. **(50 points)**

*(Match the correct letter to the correct row.)*

Symmetry	Letter
Asymmetry (no symmetry)	
Radial Symmetry (not pentaradial or biradial)	
Biradial Symmetry	
Pentaradial Symmetry	
Bilateral Symmetry	

## Sponge Anatomy

Most sponges are filter feeders, with their water filtration system as shown in Figure 3.

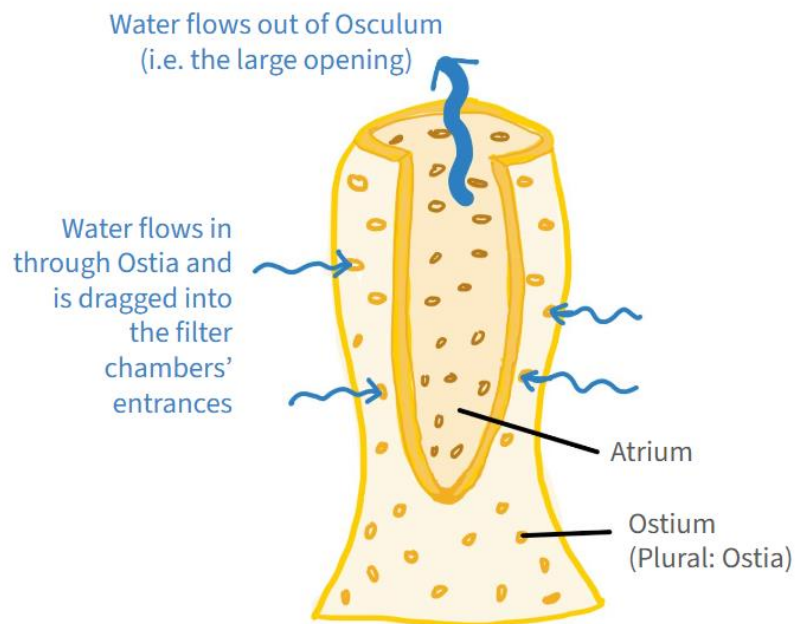

Figure 3: Structure of a sponge

Filter-feeding sponges use this filtration system to capture bacteria and other microorganisms, which are phagocytosed by amoeboid cells.

Carnivorous sponges, on the other hand, often have a different feeding mechanism that does not rely on these filters. The Ping Pong Tree Sponge (Figure 4) is a unique carnivorous sponge.

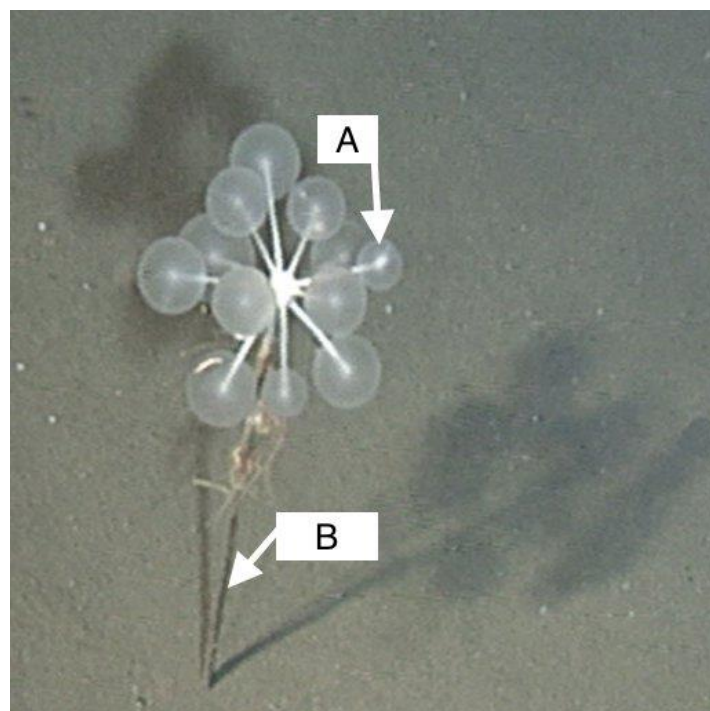

Figure 4: Ping Pong Tree Sponge (*Chondrocladia lampadiglobus*)

**Q2.** Indicate whether the following statements are true or false. **(40 points)**

(Mark each statement as true or false.)

- A. A and B are composed of different tissue types.
- B. Unlike most types of sponges, the Ping Pong tree sponge (*Chondrocladia lampadiglobus*) exhibits radial symmetry.
- C. After the Ping Pong Tree Sponge (*Chondrocladia lampadiglobus*) traps its prey on the surface of A, the prey is enveloped to enter the sponge's digestive cavity to be digested by enzymes secreted by the sponge's cells.
- D. Unlike most carnivorous sponges, the water filtration system in the Ping Pong tree sponge (*Chondrocladia lampadiglobus*) is still present as it is required to inflate structure A.

## Classification

The sister group to the Kingdom *Animalia* are a group of organisms known as “choanoflagellates”. An example of a choanoflagellate is shown below in Figure 4.

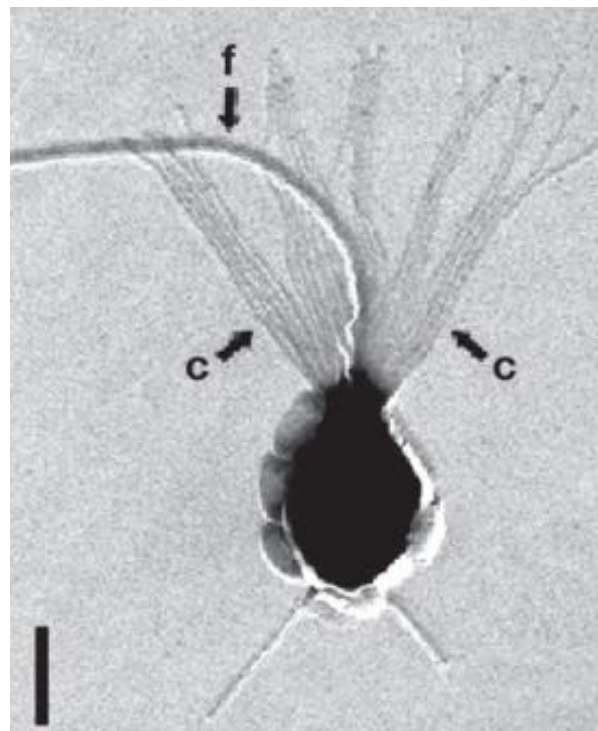

Figure 5: Choanoflagellate *Monosiga ovata*

Figure 6 shows the anatomy of a sponge along with several labelled cells.

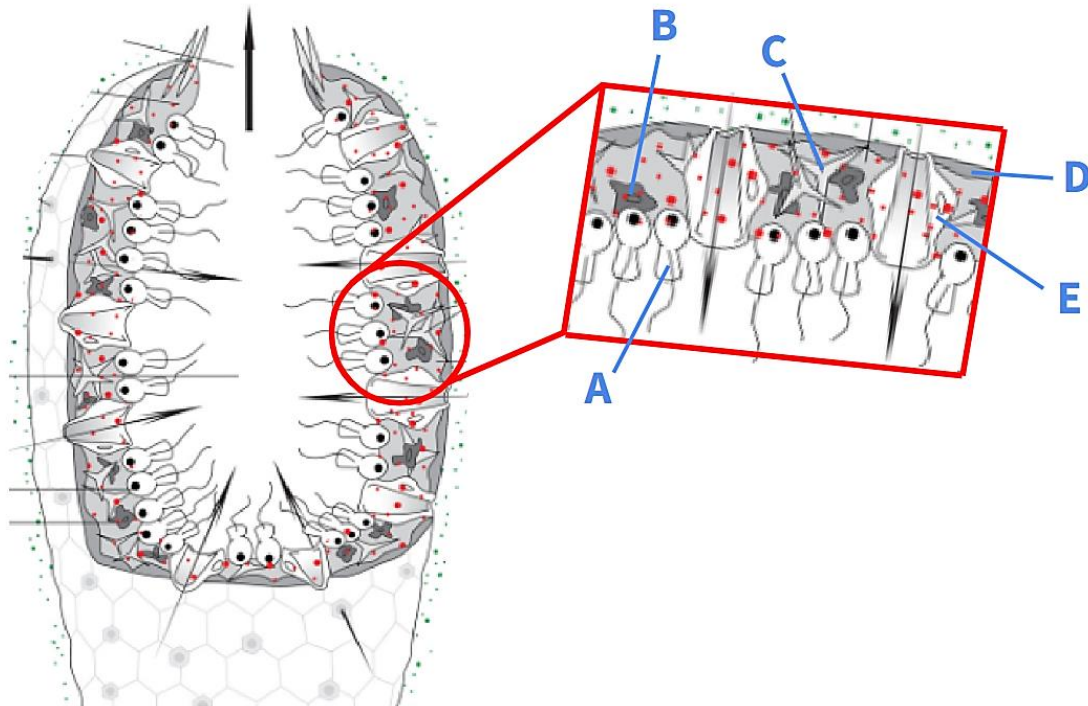

Figure 6: Anatomy of a Sponge

**Q3.** Which of the following cells is likely homologous to choanoflagellates? **(10 points)**  
*(Select the correct option.)*

- A. A
- B. B
- C. C
- D. D
- E. E

Table 1 lists the various traits of the phyla Porifera, Cnidaria, Ctenophora, and the Clade Bilateria.

Table 1: Different traits of phyla Porifera, Cnidaria, Ctenophora, and Clade Bilateria

	<b>Porifera</b>	<b>Cnidaria</b>	<b>Ctenophora</b>	<b>Bilateria</b>
Muscles	Absent	Present	Present	Present
Sensory Organs	Absent	Present	Present	Present
Hox genes	Absent	Present	Absent	Present
Digestive organs	Absent	Absent	Absent	Present
MicroRNA	Present	Present	Absent	Present



Most popular modern classifications tend to place *Porifera* as the sister group to all other clades shown above (*Cnidaria*, *Ctenophora*, *Bilateria*). However, some hypotheses place *Ctenophora* as the sister group instead.

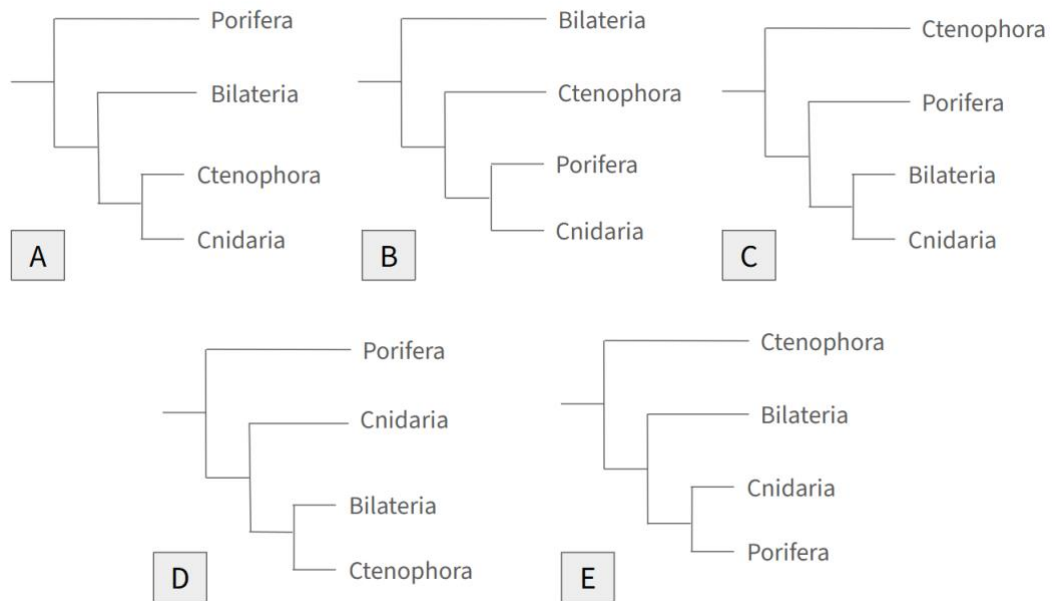

Figure 7: Hypotheses on phylogenetic classification of phyla within *Animalia*

**Q4.** Out of the following characteristics, select the one(s) that may lead to the conclusion of *Ctenophora* as the outgroup to all other clades of animals. **(10 points)**  
(Select the correct option.)

- A. Muscles
- B. Sensory Organs
- C. Hox genes
- D. Digestive organs
- E. MicroRNA

**Q5.** Based on Table 1, which of the five phylogenetic trees presented in Figure 7 is the most parsimonious? **(30 points)**  
(Select the correct option.)

- A. A
- B. B
- C. C
- D. D
- E. E

**Q6.** A group of scientists want to investigate the expression of myogenic regulators in cnidarians and their bilaterian homologues. Which of the following blotting technique(s) should they employ? **(20 points)**

*(Select all correct options.)*

- A. Northern Blot
- B. Southern Blot
- C. Eastern Blot
- D. Western Blot

# P08: Plants make me spiral

(180 points)

You discovered an unknown organism under the microscope. This organism is an autotroph. Figure 1 shows the unknown organism.

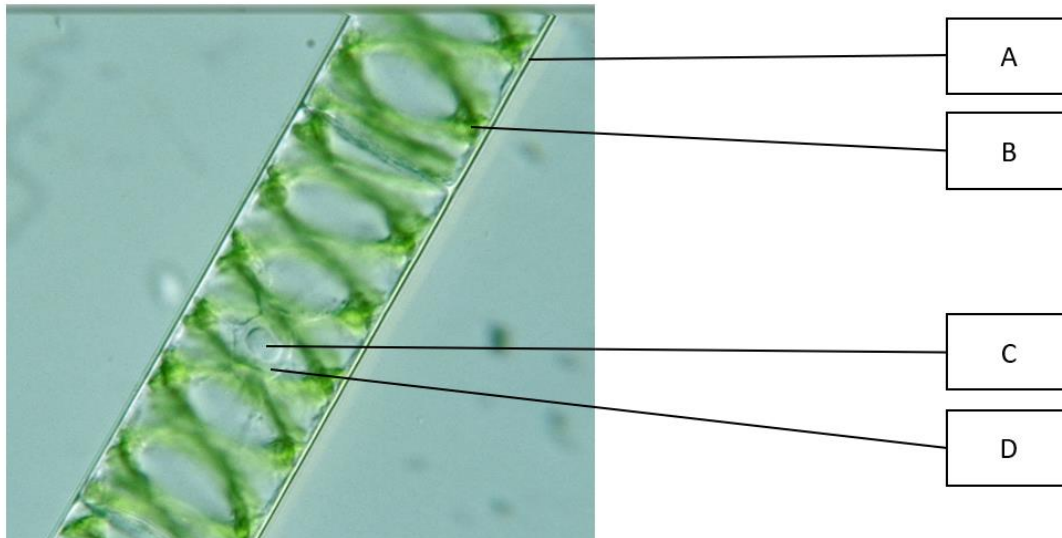

Figure 1: Unknown Organism

**Q1.** By comparing this organism to a typical plant cell, match the cell structures to their correct descriptions. Not all letters may be used, and each letter may be used more than once. If there is no such cell structure, enter *None*. **(50 points)**

*(Match the correct letters to the correct rows.)*

Description	Cell structure (A-D)
Starch	
Presence of chromatin	
Chlorophyll	
Site of glycolysis	
Contains peptidoglycan	

Small organisms like the organism in Figure 1 can be easily observed under a microscope. There are many different types of microscopes. Figures 2 to 8 show several different images taken by different types of microscopes. The images have been converted to black and white images.



Figure 2: Sporophyte

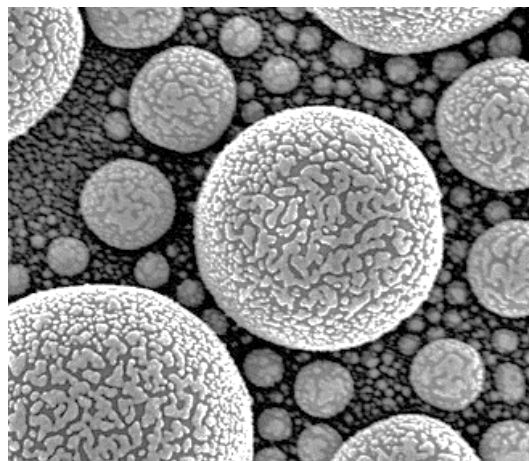

Figure 3: Pollen Grain

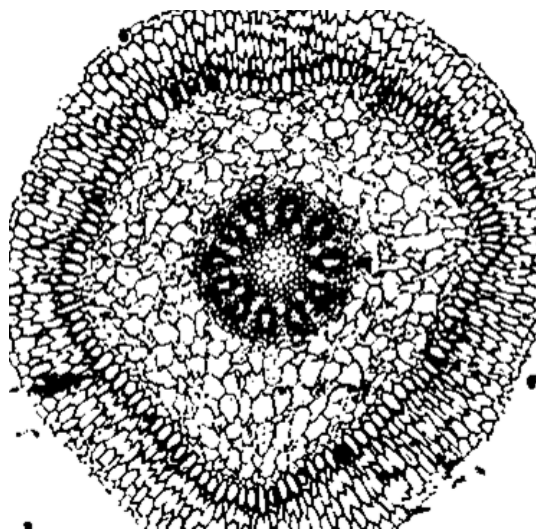

Figure 4: Unknown



Figure 5: Unknown

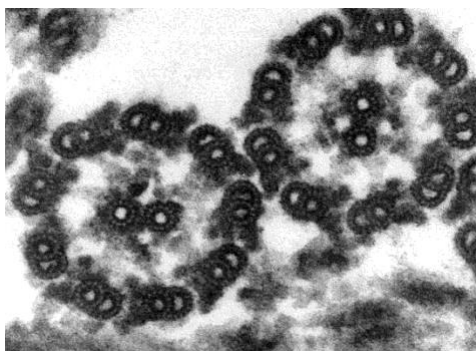

Figure 6: Unknown

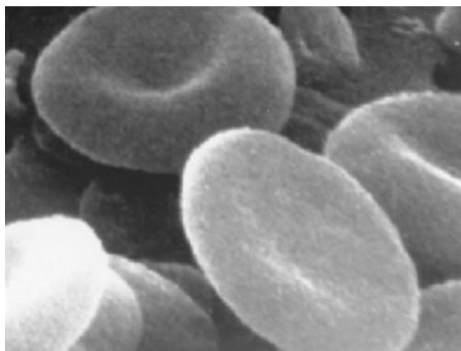

Figure 7: Unknown



Figure 8: Unknown. Bubbles present due to poor experimental techniques.

**Q2.** Each of the three figures (Figures 2-4) was captured using one of the four microscopy techniques listed below. Match the microscopy technique used (A-D) to the figures that they were used to capture. Not all techniques may be used, and techniques may be used more than once.

**(30 points)**

*(Enter the correct letter to each row.)*

- A. Scanning Electron Microscope
- B. Stereo Microscope
- C. Light Microscope
- D. Transmission Electron Microscope

Figure	Microscopy technique (A-D)
2	
3	
4	

**Q3.** Each of the four figures (Figures 5-8) was captured using one of the four microscopy techniques listed below. Match the microscopy technique used (A-D) to the figures that they were used to capture. Not all techniques may be used, and techniques may be used more than once.

**(40 points)**

*(Enter the correct letter to each row.)*

- A. Scanning Electron Microscope
- B. Stereo Microscope
- C. Light Microscope
- D. Transmission Electron Microscope

Figure	Microscopy technique (A-D)
5	
6	
7	
8	

**Q4.** Which statement is true regarding the use of a light microscope? **(20 points)**

*(Select the correct option.)*

- A. Oil needs to be used as a medium between the objective lens and the glass slide.
- B. The condenser increases the magnification of the image.
- C. The magnification of the image is calculated by the sum of the magnification of ocular lens and the objective lens.
- D. The nosepiece is used to change the magnification of the image.
- E. Viewing the microscope image with one eye results in a 2D image but viewing it with both eyes results in a 3D image.

**Q5.** You are examining an onion cell under a microscope and used the microscope to take a picture of the cell. The magnification of the image is 500x. You measured the image and found that the length of the image of the cell is 15.4cm, and the width of the image of the cell is 7.2cm. Assuming that the cell is a perfect rectangle, calculate the actual area in  $\mu\text{m}^2$  occupied by the cell. **(20 points)**

*(Enter a number correct to 3 s.f. Do not leave any units.)*

# P09: Romance of the Three Kingdoms

(100 points)

In a country conjured from dreams, there exist kingdoms A, B and C. Each kingdom consists of an infinitely large population of spiders. Our study only focuses on gene X, which has three alleles: P, Q and R. Allele P is fixed in the population of kingdom A spiders, Q is fixed for those in B and R for those in C.

Gene X codes for the number of eyes the spiders have. All spiders from kingdom A have 3 eyes, all spiders from B have 4, and all spiders living in C have 2. We pick some spiders and have them mate with one another to get the following results. All spiders who were born from a cross between spiders of kingdoms:

- A and B have 4 eyes.
- A and C have 3 eyes.

**Q1.** What is the dominance hierarchy of the three alleles? Assume complete dominance. A *greater than* sign ( $>$ ) indicates dominance (e.g.  $X > Y$  means allele X is dominant while allele Y is recessive) and an *equal sign* ( $=$ ) indicates equal dominance. **(10 points)**

(Select the correct option.)

- A.  $P > Q > R$
- B.  $P > R > Q$
- C.  $Q > P > R$
- D.  $Q > R > P$
- E.  $R > P > Q$
- F.  $R > Q > P$
- G.  $P = Q > R$
- H.  $Q = R > P$
- I.  $R = P > Q$
- J.  $P = Q = R$

**Q2.** How many eyes would a spider with parents from kingdoms B and C have? **(10 points)**

(Enter a whole number.)





We now introduce equal proportions of spiders from the three kingdoms into a new country (the P generation) and they undergo random mating. However, a disease in this country kills any spider with 4 eyes as soon as they are conceived. This does not affect the parent spiders originally from kingdom B but affects all future offspring they have (i.e., only the F1 generation is affected).

**Q3.** What proportion of all spiders survive past hatching in the F1 generation? **(20 points)**

*(Enter your answer as a percentage to the nearest whole number. Do not include the percent (%) sign.)*

**Q4.** What will the frequencies of the three alleles be after a long time in this new country? **(30 points)**

*(Enter the correct answer as a decimal correct to 3 s.f. to each row.)*

Allele	Frequency
P	
Q	
R	

**Q5.** Let us consider the country at a time when all alleles have reached new equilibrium values, as hinted in **Q4**. At this point in time, what is the probability that the offspring of two spiders, each with 3 eyes, has 2 eyes? **(30 points)**

*(Enter your answer as a decimal correct to 3 s.f.)*

# P10: This is a BLAST

(190 points)

The 2003 Nobel Prize in Chemistry was awarded to Dr Peter Agre for his discovery of aquaporin proteins. Aquaporins are a family of membrane proteins that facilitate the transport of water across cell membranes and hence help maintain water homeostasis in cells. Water molecules are able to move across cell membranes via simple diffusion or facilitated diffusion via these aquaporin channels.

Mutations in the aquaporin (AQP) genes that code for the aquaporins can lead to different diseases. You are provided with the mutated sequence of aquaporin protein X from an individual with mutations in one of the aquaporin proteins. As there are many different aquaporin proteins, you need to make use of the Basic Local Alignment Search Tool (BLAST) to determine which aquaporin protein Protein Sequence X belongs to.

BLAST is a tool that finds regions of similarity between biological sequences by comparing sequences of nucleotides or proteins to known sequence databases to find the closest matches. You will first be making use of the BLAST tool to determine which aquaporin protein the unknown protein belongs to.

## Procedure

1. In a web browser, load <https://blast.ncbi.nlm.nih.gov/>.
2. Select the most appropriate BLAST option in the Web BLAST section. You need to select the one that allows you to input your protein sequence and subsequently outputs the most similar protein sequences in the databases.
3. Enter the mutated sequence of protein X into the query box.
4. Under Databases, select “Standard databases (nr etc.):”.
5. Under Standard, select “Non-redundant protein sequences (nr)”. Leave the optional selections blank.
6. Under Algorithm parameters, leave everything else as default.
7. Click the “BLAST” button.

You will be redirected to a Format Request Page as BLAST compares your protein sequence against their databases. Once the job request is complete, you will be redirected to the results page.

The E-value refers to the number of expected hits of similar quality (score) that could be found just by chance alone. Hence, the lower the E-value, the better the alignment.

8. Select the protein sequence with the best E-value and highest percent identity score (Per. Ident). Ensure that the protein chosen is found in humans.

**Q1.** What is the identity of Aquaporin protein X? **(20 points)**

*(Select the correct option.)*

- A. Aquaporin-1
- B. Aquaporin-2
- C. Aquaporin-3
- D. Aquaporin-4
- E. Aquaporin-5
- F. Aquaporin-6
- G. Aquaporin-7
- H. Aquaporin-8
- I. Aquaporin-9
- J. Aquaporin-10
- K. Aquaporin-11

Amino acids can be classified based on their physical and chemical properties. Figure 1 shows a Venn diagram of the amino acids and their properties.

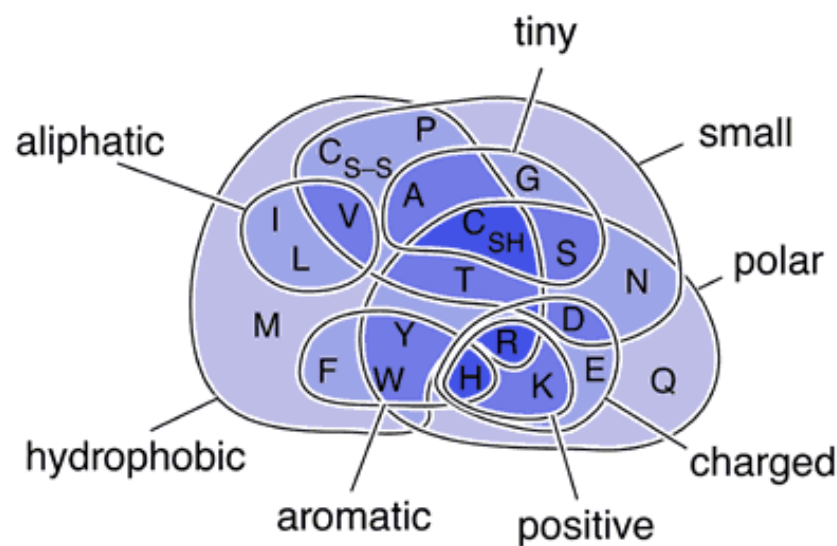

Figure 1: Amino Acid Properties.

9. Select the alignment view “Pairwise with dots for identities”.

**Q2.** How many amino acid mutations are there in the mutated sequence? **(10 points)**

*(Enter a whole number.)*

The interface will show you two rows: Query, and Sbjct (Subject). The former is the sequence which you uploaded, while the latter is the sequence matched from the database. The dots represent that the amino acid is the same at that position, while the red amino acids represent a mismatch in amino acid at that position.

**Q3.** At which position(s) is there an amino acid mutation from polar to hydrophobic? If there are more than one positions, enter your answer as the **sum** of all the positions. **(20 points)**

*(Enter a whole number.)*

**Q4.** At which position(s) is there an amino acid mutation from an amino acid with a charge to an amino acid with a **different** charge? If there are more than one positions, enter your answer as the **sum** of all the positions. **(20 points)**

*(Enter a whole number.)*

We would also like to see the 3D structure of the normal aquaporin protein X in humans and how variants affect it using the Universal Protein Resource (UniProt).

10. Load <https://www.uniprot.org/> on a web browser.
11. Search for the protein using the name of the protein in **Q1**.
12. Select the entry that is your protein. Ensure you chose the correct species, and that the entry is a reviewed entry by Swiss-Prot (indicated by a yellow file icon with a star).
13. Select “Variant Viewer”.

Variants in genes can be classified into one of five clinical significances: Pathogenic, Likely pathogenic, Variant of Uncertain Significance (VUS), Likely benign, and Benign.

**Q5.** What is the clinical significance of the third last mutation in the unknown protein sequence? **(20 points)**

*(Select the correct option.)*

- A. Pathogenic
- B. Likely pathogenic
- C. VUS
- D. Likely benign
- E. Benign
- F. Not reported

14. Select “Entry”.
15. Scroll down to “Sequence”.
16. Store the normal sequence of protein X in a .txt file.



**Q6.** With reference solely to the information on UniProt regarding this entry, indicate whether the following statements are true or false. **(40 points)**

*(Mark each statement as true or false.)*

- A. There are many alpha helices in the secondary structure of Protein X.
- B. The gene coding for Protein X can be found on chromosome 9.
- C. Protein X is likely transported to the smooth endoplasmic reticulum and the Golgi apparatus for addition of a carbohydrate chain during post-translational modification.
- D. A loss-of-function mutation of Protein X will result in a slower rate of uptake of water by cells in the small intestine.

Next, we will use the Protein Parameters (ProtParam) tool to predict the changes in the physical and chemical parameters of mutated protein X as compared to the normal protein X.

- 17. Load <https://web.expasy.org/protparam/>.
- 18. Copy and paste the normal sequence of Protein X into the query box.
- 19. Press the “Compute parameters” button.
- 20. Repeat steps 18 and 19 for the mutated protein sequence.

The isoelectric point (pI) of an amino acid is the pH at which it bears no net charge. For an amino acid with no polar side chain, it has a net charge of zero at physiological pH as it is in its zwitterionic form.

**Q7.** What is the theoretical pI of normal protein X and the mutated protein X? **(20 points)**

*(Enter your answer correct to 3 s.f. to each row.)*

<b>Protein</b>	<b>Theoretical pI</b>
Normal Protein X	
Mutated Protein X	

Other than the mutated protein sequence X, you are also provided with four other mutated sequences of different aquaporin proteins. You are tasked to find the evolutionary relationship between the five aquaporin protein sequences. To do so, we will make use of a multiple sequence alignment programme called ClustalW.

- 21. Load <https://www.genome.jp/tools-bin/clustalw>.
- 22. Copy and paste Protein Sequences A to D into the query box. Do not edit anything.
- 23. You will also need to include the **normal** sequence of Protein X in the search query.

Protein sequences entered in the search query must be in the FASTA format. The FASTA format comprises of the header and the sequence. The header starts with a “more than” sign (>), followed by the name of the sequence without spaces. A carriage return is inserted or the “enter” key is clicked to continue on the next line, and the protein sequence is inserted. As an example, the FASTA format has already been done for you for Unknown proteins A to D.

24. Format the **normal** protein sequence in **Q1** in the FASTA format and paste it at the bottom of the search query.
25. Select “CLUSTAL” as the output format.
26. Select “FAST/APPROXIMATE” for Pairwise Alignment.
27. Leave the “more Detail Parameters” as default.
28. Click the “Execute Multiple Alignment” button.
29. Click the dropdown menu and select “FastTree”.
30. Click the “Exec” button.
31. Once the job is completed, click “without branch length”.

You should obtain a phylogram similar to that in Figure 2.

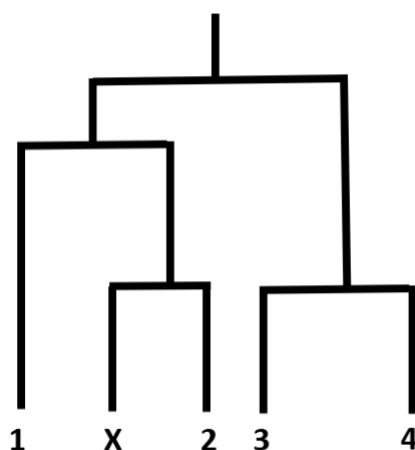

Figure 2: Phylogram. X represents the **normal** protein sequence X.

**Q8.** Match the unknown protein sequences A-D to the correct numbers in Figure 2. Note that the letter corresponding to number 3 in Figure 2 comes **alphabetically before** that of number 4. **(40 points)**

*(Enter the correct letter to the correct row.)*

Number in Figure 1	Protein Sequence (A-D)
1	
2	
3	
4	

# P10 – Resources

Links in the problem can be found here:

- BLAST: <https://blast.ncbi.nlm.nih.gov/>
- UniProt: <https://www.uniprot.org/>
- ProtParam: <https://web.expasy.org/protparam/>
- ClustalW: <https://www.genome.jp/tools-bin/clustalw>

>MutatedProteinSequenceX

MWELRSIAFSRAVFAEFLATLLFVFFGLGSALNWPQALPSVLQIPMAPGLGIGTLVQALGHISGAHI  
 NPAVTVACLVGCHVSVLRAAFYVAAMLLGAVAGAALLHEITPADIRGDLAVNALSNSTTAGQAVT  
 VELFLTLQLVLCIFASTDERRGENPGTPALSIGFSVALGDLLGIHYTGCSMNPARS LTPAVVTGKFDD  
 HWWFWIGPVVGAILGSLLYNYVLAPPAKSLSERLAVLKNLEPDTDWEEREVRRRQSVELHSPQSLP  
 RGTKA

>UnknownProteinSequenceA

MKKEVCSVAFLKAVFAEFLATLIFVFFGLGSALKWTFALPTILQIALAFGLAIGTLAQUALGPVSGGHI  
 NPAITLALLVGNQISLLRAFFYVAAALVGAIAGAGILYGVAPLNARGNLAVNALNNNTTQGGAMV  
 VELILTFQLALCIFASTDSRRTSPVGPALSIGLSVTLGHLVGIYHTGCSMNPARSFGPAVVMNRFSP  
 AVLFWVGPVIGAVLAAILYFYLLFPNSLSLSEVAIIKGTYPDEDWEEQNEERKKTMELTTR

>UnknownProteinSequenceB

MSGEIAMCEPEFGNDKAREPSVGGWRWLMWYERFVQPCLVELLGSALFIFIGCLSVIENGTDTGLL  
 QPALAHGLALGLVIATLGNPSGGHFNPAVSLAAMLIGGLNLVMLLPYWVSFLLGGMLGAALAKA  
 VSFWERFWNASGAATVQEQQQVAGALVAEIIITLLALAVCMGAINKTKGPLAPFSIGFAVTV  
 DILAGGPVSGGCMNPARAFGPAVVRNHWNFWHISTAGPLLAGLLVGLLIRCFIGDGKTRLILKAR

>UnknownProteinSequenceC

MVFTQAPAEIMGHLRIRSLARQCLAESLGVFVLMMLTQGAVAQAVTSGETKGNFFTMFLAGSLA  
 VTIAIYVGGNVSGAHLNPAFSLAMAIVGRLVVVKLPIYILVQLLSAFCASDATYVLYHDALQNYTG  
 MNLTVTGPKETASIFGTYPAPYLSLNNGFLDQVLGTAMLIVGLLAILDRRNKGVPAGLEPVVVGML  
 ILALGLSMGANCGIPLNPARDLGPRLFTYVAGWGPEVFSAGNGWWWVPVAPLVGAYVGTATYQ  
 LLVALHHPEGPEPAQDLVSAQHKPSELETPASAQMLECKL

>UnknownProteinSequenceD

MVQASGHRRSTRGSKMVSWSVIAKIQEILQRKMVREFLAEFMSTYVMMVFGLGSVAHMVLNKKY  
 GSYLGVNLGFGFGVAMGRHVAGRISGAHMNAAVTFANCALGRVPWRKFPVYVLGQFLNMFLAA  
 ATIYSLFYTAILHFSGSQLMVTGPVATAGIFATYLPDHMTSWRGLNEAWLTGMLQLCLFAITDQE  
 NNPALPGTEALVIGILVPIIGVSLGMNTGYAINPSRDLPKRIFTFIAGWGKQVFSNGENWWWVPVVA  
 PLLGAYLGGIYLVFIGSTIPREPLKLEDSVASEDHGITVLPKMG SHEPTISPLTPVSVSPANRSSVHPA  
 PPLHESMALEHF

# P11: Hold Dear to Me

(150 points)

Parabiosis is a technique that involves the surgical joining of two living organisms such that they develop a single, shared physiological system as their blood vessels are connected together. This allows blood and its contents to be shared between both animals.

Parabiosis was used to investigate obesity and diabetes in mice. Two mice lines Db (diabetic) and Ob (obese) have the same overeating phenotype. This is caused by a recessive mutation  $db^-$  and  $ob^-$  respectively. Figure 1 shows the results of parabiosis between wild-type, diabetic, and obese mice.

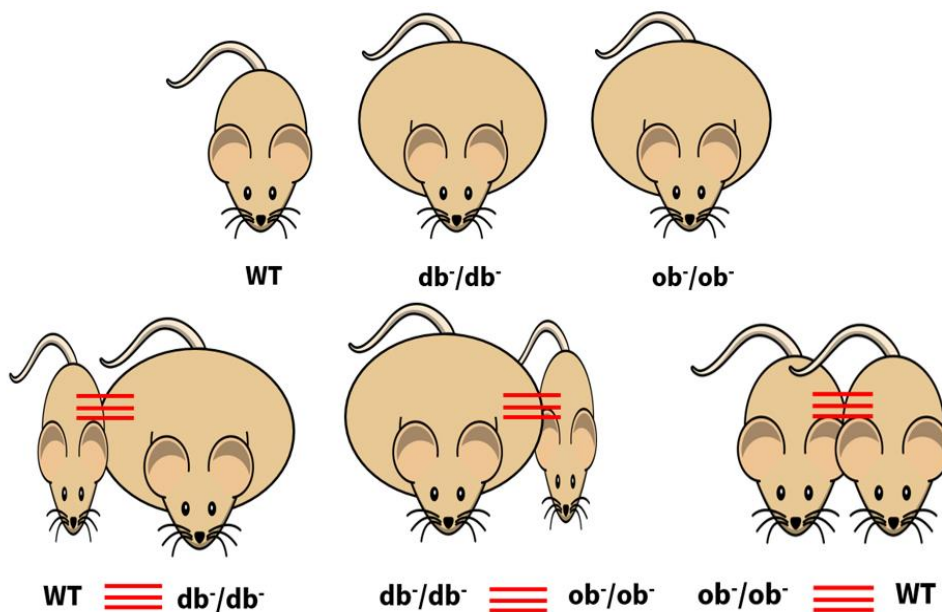

Figure 1: Results of Parabiosis between WT,  $db/db$ , and  $ob/ob$  mice.

Figure is to scale.

**Q1.** Indicate whether the following statements are true or false. (40 points)

(Mark each statement as true or false.)

- The  $ob$  gene codes for a hormone that directly causes weight loss.
- The  $ob$  gene causes the production of a satiety factor.
- Production of satiety factor in WT mice will prevent starvation in  $ob/ob$  mice.
- $ob/ob$  mice produce excessive amounts of a substance that reduces appetite.



**Q2.** Indicate whether the following statements are true or false. **(40 points)**

(Mark each statement as true or false.)

- A. The *db* gene codes for a hormone receptor that directly causes weight loss.
- B. We can deduce that the *db* gene definitely codes for leptin.
- C. If *db<sup>-</sup>/db<sup>-</sup>* mice were to be parabiosed with *ob<sup>-</sup>/ob<sup>-</sup>* mice and WT mice together (triple parabiosis), *db<sup>-</sup>/db<sup>-</sup>* mice will overeat.
- D. If *db<sup>-</sup>/db<sup>-</sup>* mice were to be parabiosed with *ob<sup>-</sup>/ob<sup>-</sup>* mice and WT mice together (triple parabiosis), *ob<sup>-</sup>/ob<sup>-</sup>* mice will starve.

**Q3.** The two genes are not linked. What is the expected F<sub>2</sub> phenotypic ratio if *ob<sup>-</sup>/ob<sup>-</sup> db<sup>-</sup>/db<sup>-</sup>* mice are crossed with *ob<sup>-</sup>/ob<sup>-</sup> db<sup>-</sup>/db<sup>-</sup>* mice? Leave the ratio in its simplest form. **(30 points)**

(Enter a whole number in each row.)

Behaviour	Ratio
Starving behaviour	
Normal eating behaviour	
Overeating behaviour	

In a different experiment to determine the factors affecting ageing in mice, you performed a parabiosis experiment with two mice surgically joined at the abdomen. You investigated the rates of methylation of the chromatin and telomere lengths in mice in parabiosis. Figures 2 and 3 show the results.

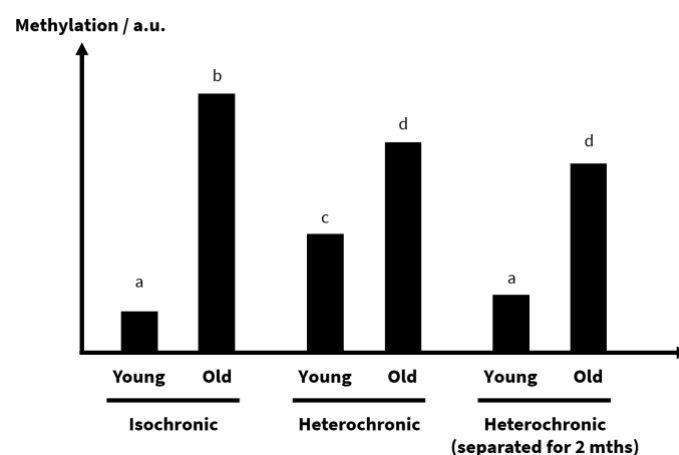

Figure 2: Degree of methylation in each mice. “Isochronic” and “Heterochronic” mice had their data taken while they were still in parabiosis for 1 week. “Heterochronic (separated for 2 months) had their data taken after 2 months of surgical separation from parabiosis.

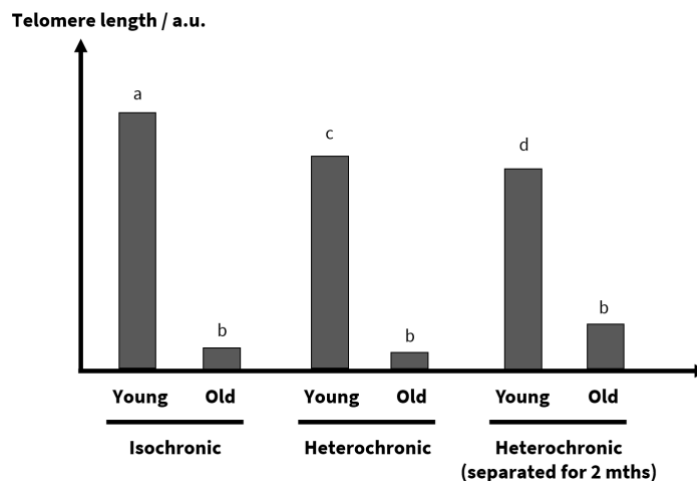

Figure 3: Telomere Length in each mice. “Isochronic” and “Heterochronic” mice had their data taken while they still in parabiosis for 1 week. “Heterochronic (separated for 2 mths)” had their data taken after 2 months of surgical separation from parabiosis.

**Q4.** Indicate whether the following statements are true or false. **(40 points)**

*(Mark each statement as true or false.)*

- An “old-age” factor that upregulates DNA methyltransferase is produced by the old and circulates in the bloodstream.
- A “youthful factor” that upregulates DNA methyltransferase is quickly degraded in old mice.
- Telomerase is secreted in bloodstream of young mice.
- There are relatively higher rates of mitosis in young mice than old mice.

# P12: How should I choose my flowers?

(130 points)

Jen is trying to buy some flowers for her friend's dance concert. Her friend loves flowers and gives her a specific set of instructions on what flower to get.

Her friend, Lily, gave the following set of instructions:

1. The flower needs to be zygomorphic
2. The flower needs to have an inferior ovary
3. The flower belongs to a monocotyledonous plant
4. The flower is unisexual

**Q1.** Which of the following plants have flowers corresponding to the above set of instructions?

(20 points)

*(Select the correct option.)*

- A. Valerian herb
- B. Sweet pea
- C. Antirrhinum
- D. Chayote
- E. Coconut
- F. Sack-shaped catasetum

Jen also noticed that some of the flowers she saw at the florist bloomed in clusters. After some googling, she discovers that such a blooming pattern is known as inflorescence. There is determinate and indeterminate inflorescence. For determinate inflorescence, the oldest flower is located at the tip and younger flowers bud moving down the axis towards the base. For indeterminate inflorescence, the oldest flower is located at the base and younger flowers bud moving up the axis towards the tip.

Figure 1 shows several flowers with different types of inflorescences.



Figure 1: Flowers with different inflorescences.  
(Left): Flower 1. (Middle): Flower 2. (Right): Flower 3.

**Q2.** Based on Figure 1, indicate whether each type of inflorescence is determinate or indeterminate by entering *D* if the flower has determinate inflorescence and *N* if the flower has indeterminate inflorescence. **(30 points)**

(Enter “D” or “N” to each row.)

Flower	Type of inflorescence (D or N)
1	
2	
3	

There are several types of indeterminate inflorescence as follows:

- **Spike:** The flowers are attached directly to the axis without being attached to a pedicel
- **Capitulum:** The flowers are attached directly on a broad, flat peduncle, making the inflorescence seem like a single flower
- **Raceme:** The flowers are each attached to a pedicel, which is in turn attached to the axis.
- **Corymb:** The pedicels of the lower flowers are longer than the pedicels of the upper ones, making the overall appearance of the inflorescence to be flat
- **Umbel:** The flowers are attached to pedicels, with each pedicel growing from about the same point at the tip of the peduncle, giving an umbrella-like shape for the inflorescence.

Figure 2 shows several flowers with different types of indeterminate inflorescences.

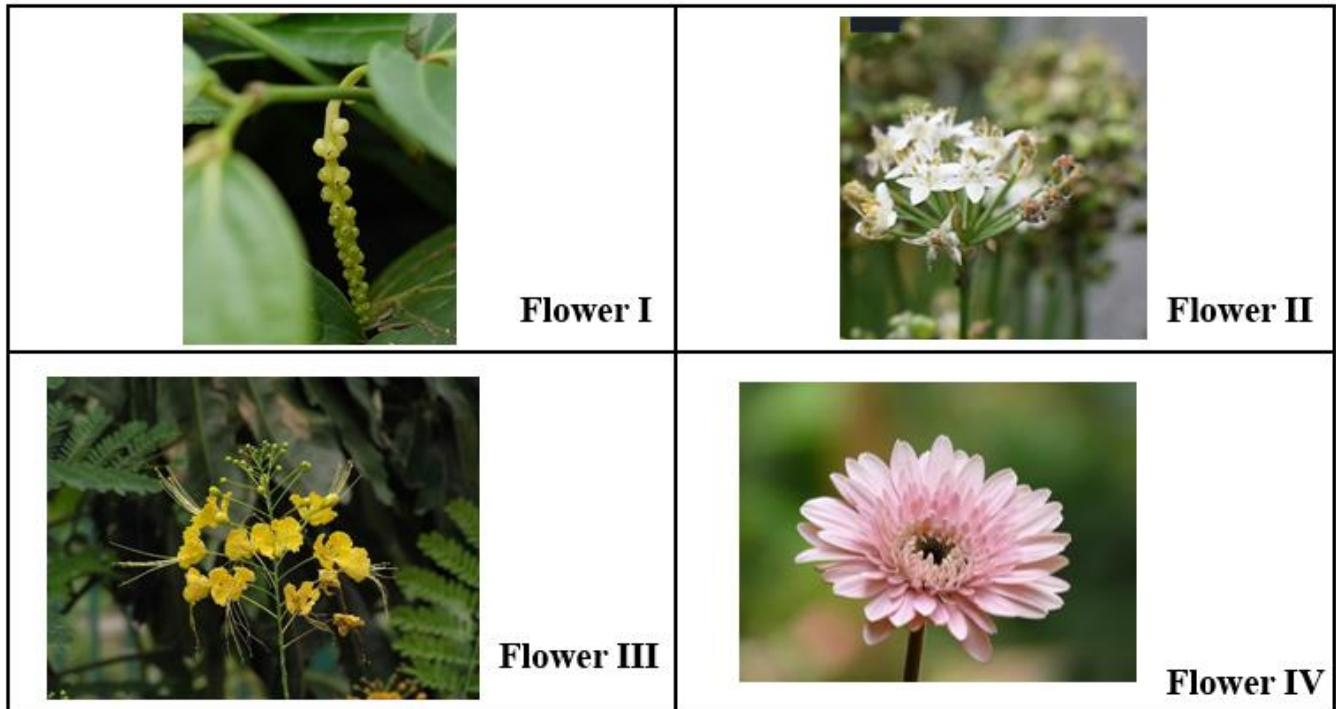

Figure 3: Flowers with different indeterminate inflorescences

**Q3.** Match the type of indeterminate inflorescence (1-5) to the flowers in Figure 2. **(40 points)**  
*(Enter a number to each row.)*

1. Spike
2. Capitulum
3. Raceme
4. Corymb
5. Umbel

Flower	Type of indeterminate inflorescence (1-5)
I	
II	
III	
IV	

Jen also happened to be buying flowers for her friend Jade, who was an eccentric biologist. Jade asked for a bouquet of flowers comprising 1 stalk of Flower 1, 2 stalks of Flower 2, 3 stalks of Flower 3 and 4 stalks of Flower 4 and represented each flower using cryptic floral formulae as seen in the table below.

<b>Flower 1</b>	<b>Flower 2</b>
$\% \text{♀ } K_5 C_5 A_{5-\infty} \underline{G}_1$	$\oplus \text{♂ } K_4 C_4 A_{2+4} \underline{G}_{(2)}$
<b>Flower 3</b>	<b>Flower 4</b>
$\oplus \text{♀ } P_{3+3} A_{3+3} \underline{G}_{(3)}$	$\oplus \text{♂ } K_{(5)} C_{(5)} A_5 \underline{G}_{(2)}$

Jen entered a floral shop and was presented with a plethora of options. Jen was confused about which flowers she had to buy, could you help her?

**Q4.** Match Flowers 1 to 4 to the flower that they represent (A-H) in Figure 3. **(40 points)**

*(Match the correct letter to the correct row.)*

Flower	Flower as represented in Figure 4 (A-H)
1	
2	
3	
4	

**A**



**B**



**C**



**D**



E



F



G

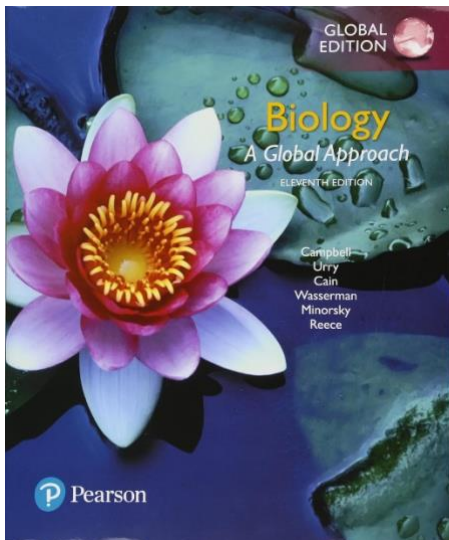

H



Figure 3: Different flowers



# P13: Don't cry over spilt milk, EMMA!

(150 points)

Emma recently learnt about Northern Blot, which is used to detect gene expression by analysis of the amount of mRNA produced by the cell. Her professor has tasked each student to come up with two experiments to show their understanding of Northern Blot.

Emma loves milk a lot and always brings a bottle of milk with her at all times. As she carried her milk bottle (Figure 1) into the lab, she realised that milk contains much lactose, which is a disaccharide found in large quantities in milk, and that she had recently read about the *lac* operon. She could possibly perform a Northern Blot experiment on it!



Figure 1: Emma's Milk Bottle

The *lac* operon in *E. coli* encodes for  $\beta$ -galactosidase, which breaks down lactose into glucose and galactose. Emma thus created several *E. coli* mutant cells and allowed them to grow in media containing lactose but no glucose for 24 hours. She then performed Northern Blot against  $\beta$ -galactosidase mRNA.

After performing the Northern Blot, she noticed that there are three different intensities of the band produced: None, Low, and High.

**Q1.** Help Emma match the following strains of *E. coli* with the intensity of the band (1-3) expected after the Northern Blot. **(60 points)**

(Enter the correct number to the correct row.)

- 1: None
- 2: Low
- 3: High

<b><i>E. coli</i> strain</b>	<b>Intensity of band (1-3)</b>
Normal strain	
Strain with nonsense mutation in <i>lacI</i>	
Strain with a permanent binding of allolactose to the repressor, and glucose is added to the cell	
Strain with a premature stop codon in <i>lacZ</i>	
Strain with inactive permease	
Strain with a mutation in the CAP-binding site such that CAP can no longer bind to it	

As she finished her experiment, she decided to reward herself with a sip of milk. Sipping on her milk bottle (Figure 1), she realised babies drink milk too. Maybe she can perform an experiment on morula cells!

Emma decided to extract cells from the adrenal cortex, adrenal medulla, embryo morula, and a malignant tumour. She performed Northern Blot by isolating the mRNAs produced by each of the cells and then carried out gel electrophoresis separately using radioactive probes specific to five sequences of mRNA (A - E). These mRNA sequences code for calcitonin, epinephrine, histone H1, P53 protein, and telomerase, but not necessarily in that order. Unfortunately, Emma was careless and spilt milk on her paper, covering up to what the mRNA sequences and cells correspond. You told her not to cry as there is no use crying over spilt milk, and instead promised her that you would use her results to determine what the proteins added were.

The results are shown in Figure 2.

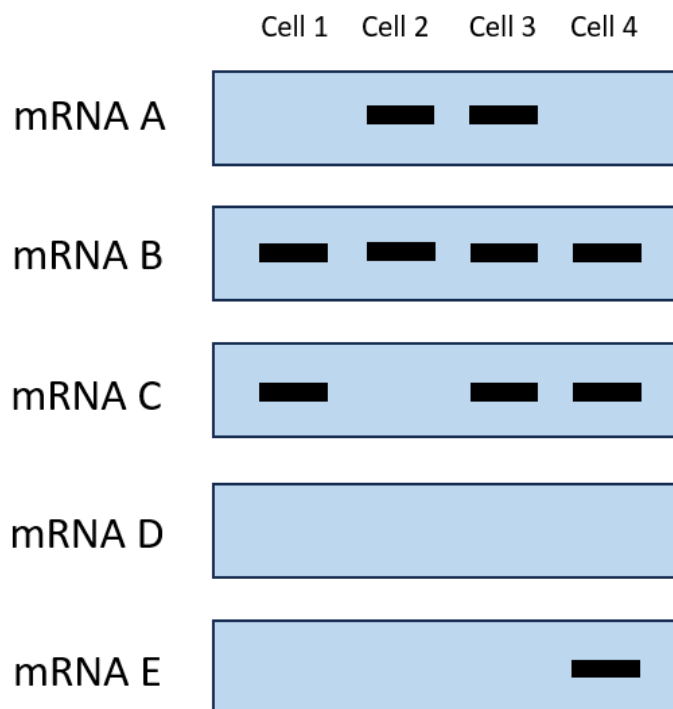

Figure 2: Gel electrophoresis using probes complementary to five different mRNA which code for proteins

**Q2.** Help Emma match the mRNA letters (A, B, C, D, E) to the protein of which they code for. **(50 points)**

*(Match the correct letter to the correct row.)*

Identity of Protein	Letter
Calcitonin	
Epinephrine	
Histone H1	
P53	
Telomerase	



**Q3.** Help Emma match the cell numbers (1, 2, 3, 4) to their correct identities. **(40 points)**

*(Match the correct number to the correct row.)*

<b>Identity</b>	<b>Number</b>
Adrenal Cortex Cells	
Adrenal Medulla Cells	
Morula Cells	
Tumour Cells	

Hope that this is a poignant reminder not to bring food and drinks into the lab and that Emma would not do it again.

# P14: Hereditary Cancer

(110 points)

Cancer is one of the leading causes of death and disability in the world. In particular, breast cancer is also the most common cancer in women in Singapore. One of the common genes responsible for breast cancer, BRCA, can be inherited.

Below is the family tree of a family with a history of breast cancer. Assume that there are no *de novo* mutations in the BRCA gene during gametogenesis by any individual in the following pedigree.

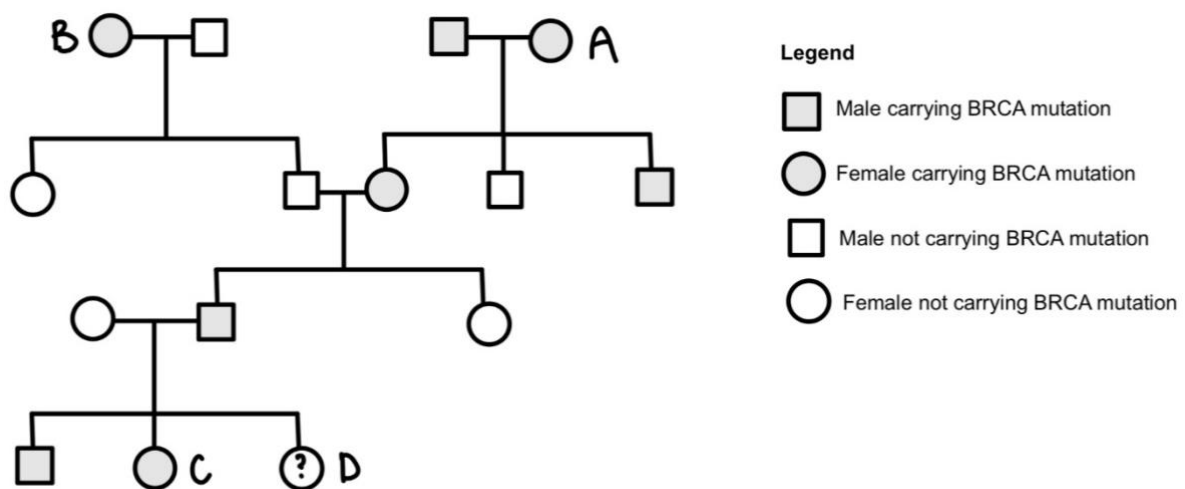

Figure 1: Pedigree

**Q1.** Indicate whether the following statements are true or false. (40 points)

(Mark each statement as true or false.)

- A. From the pedigree, individual A definitely suffered from breast cancer.
- B. Given that individuals A and B had different mutations in the BRCA gene, the mutation in individual C is the same as the mutation in individual B.
- C. It is unknown if individual B inherited the BRCA mutation from her parents.
- D. The likelihood of individual D having breast cancer is 50%.

Individuals A and B both have breast cancer. Their information is listed in the table below.

**Patient A:** Stage 3 breast cancer, HER2+, 1081delG BRCA1 mutation, Oestrogen and Progesterone receptor negative

**Patient B:** Stage 2 breast cancer, HER2-, 4265delCT BRCA2 mutation, Oestrogen receptor positive

**Q2.** There are many different founder mutations for the BRCA1/2 genes, including BRCA1 founder mutation (1081delG) from South China and BRCA2 mutation (4265delCT) in the Philippines. Given that BRCA1/2 genes are both tumour suppressor genes, which of the following treatment(s) could be beneficial for **both** patients A and B? **(20 points)**

*(Select all correct options.)*

- A. Mastectomy
- B. PARP inhibitor
- C. Herceptin (trastuzumab)
- D. Hormone therapy

The BRCA1/2 gene codes for proteins involved in a process named “homologous recombination”. Homologous recombination is one of the many methods of DNA repair in our cells to ensure genomic stability. Other DNA repair mechanisms include mismatch repair, nucleotide excision repair, non-homologous end joining and base excision repair.

The descriptions to the 5 different methods of repair are given below:

Code	Name of Repair Method	Repair Mechanism
I	Homologous recombination	Process where an undamaged DNA molecule is invaded by a damaged molecule of identical or very similar sequence. Undamaged DNA is then used as a template for the repair of the damaged DNA via complementary base pairing.
II	Mismatch repair	Process responsible for correcting errors made during DNA replication, hence preventing these mutations from becoming permanent in dividing cells.
III	Nucleotide excision repair	Main process responsible for removing bulky DNA lesions.
IV	Non-homologous end joining	A type of DNA repair which mediates the direct religation of the broken DNA molecule does not require a homologous template for repair of the DNA lesion like in homologous recombination.
V	Base excision repair	Process responsible for removing small base lesions that do not significantly distort the DNA helix structure.



**Q3.** Match the following DNA lesions to the code of the repair method (I-V) that is most likely responsible for repairing the damage. Use each roman numeral only once. **(50 points)**

*(Enter a roman numeral to each row.)*

<b>Lesion</b>	<b>Repair Method (I-V)</b>
Thymine dimer	
Guanine replaced by thymine due to a cytostatic drug	
DNA interstrand crosslink	
DNA polymerase wrongly adding cytosine instead of adenine	
DNA double-stranded breaks at G <sub>1</sub> phase of cell cycle	

# P15: Golden Apple Archipelago

(210 points)

The Golden Apple Archipelago is a tropical region near the coast of *Biotropica* with many rainforests. The archipelago is named after the **golden apple tree**, which is the most common native tree in the region, dominating most of the rainforests. The golden apple tree is part of the Myrtaceae family, growing to variable heights (from shrubs to tall trees) while being able to grow at variable elevations, temperatures and rainfall intensity.

The **sunsettia** is a small, shade-tolerant tree that was introduced to the Golden Apple Archipelago more than 200 years ago. While also from the Myrtaceae family, the sunsettia tree is shorter at its maximum height compared to the golden apple tree.

The sunsettia is considered an invasive species and has spread throughout some of the rainforests in the Golden Apple Archipelago. Figure 1 shows a diagrammatic map of the region and the relative densities of the sunsettia, dated 2025.

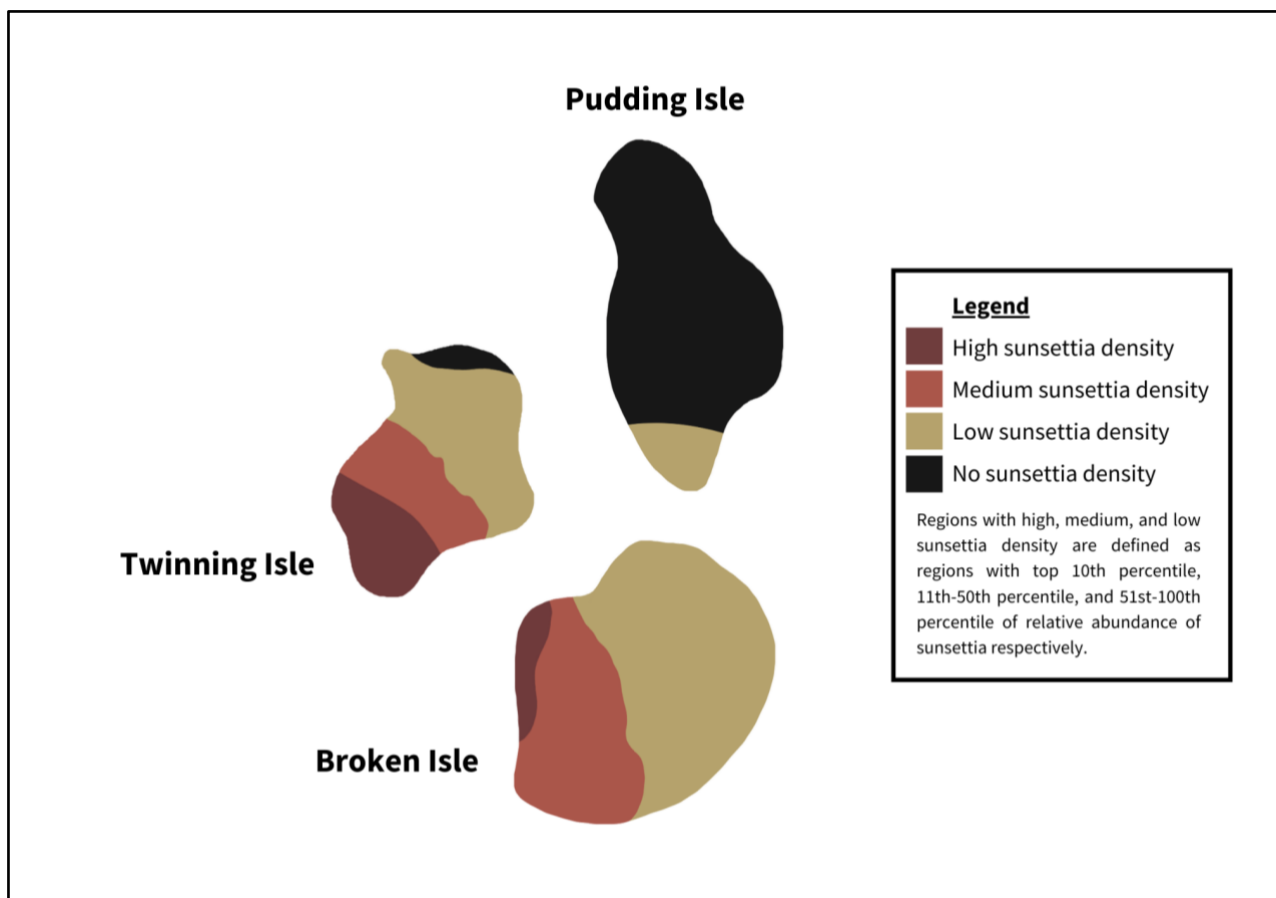

Figure 1: Map of the Golden Apple Archipelago, dated 2025.





In 2025, a team of ecologists was commissioned to study the population dynamics of the sunsettia in the Golden Apple Archipelago for **16 years (2025 to 2040 inclusive)**. The team marked out five randomly selected replicate study plots of 0.25 ha on each of the three islands, selecting intact golden apple forest regions with **low sunsettia density**. All study plots have similar initial densities of the sunsettia with a range of stem diameters represented.

## Analysis I: Population counts

At the start of 2025, in each of the study plots, all sunsettia stems with a diameter at breast height (DBH) of at least 2 cm were tagged. At the start of every year, new eligible sunsettia recruits were tagged, while dying sunsettia stems were noted down and no longer included in the study population from that year onward.

A portion of the collected data is shown in the table below.

	2025	2026	2027	2028
Population count on Twinning Isle (stems/ha)	13,503	13,763	14,040	15,558

Ecologists use annual population counts to study the annual population growth of a population, denoted as **lambda**. The lambda of a year is the ratio of population sizes between the following year and the current year.

$$\lambda = \frac{N_{t+1}}{N_t}$$

**Q1.** Calculate the average lambda of the sunsettia population at the study site on Twinning Isle from 2025 to the start of 2028. **(20 points)**

*(Enter your answer correct to 3 s.f.)*

**Q2.** Use your calculated average lambda to estimate the sunsettia count in 2029, in stems/ha. **(10 points)**

*(Enter your answer correct to the nearest whole number.)*

**Q3.** In a 0.1 ha subset of a Twinning Isle study plot, 34 sunsettia plants were newly tagged in 2026. Estimate the *per capita* death rate of the sunsettia in 2025, in deaths/stem. **(20 points)**

*(Enter your answer correct to 3 s.f.)*

Figure 2 shows the density of sunsettia stems between 2025 and 2040 on each isle based on the information gathered from the study plots.

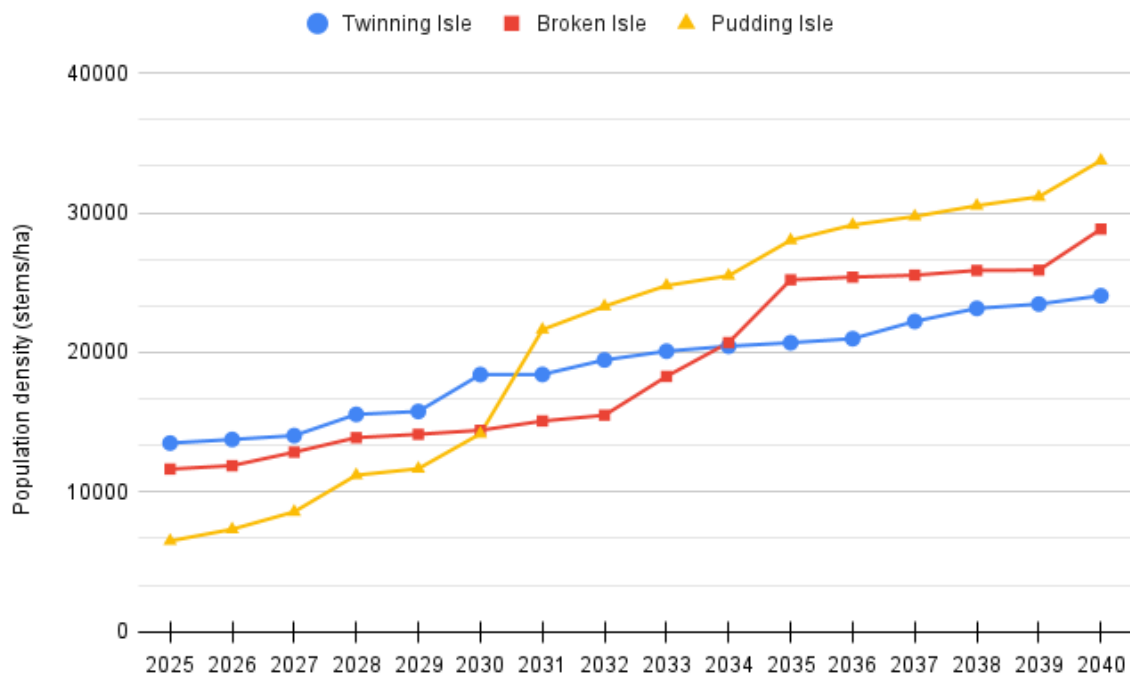

Figure 2: Density of sunsettia stems per year.

**Q4.** Indicate whether the following statements are true or false. **(40 points)**

*(Mark each statement as true or false.)*

- A. The calculated lambda ( $\lambda$ ) will increase if the population size data was given in stems/km<sup>2</sup>.
- B. The data represented in Figure 2 indicates an overall increase in relative abundance of the sunsettia in all three study sites from 2025 to 2040.
- C. Figure 2 suggests that Twinning Isle has the greatest environmental influences that hinder sunsettia growth out of the three isles.
- D. A similar gradient in the graph of population density per year, such as that of the Pudding Isle sites from 2036 to 2039 in Figure 2, indicates an approximately constant lambda.

# Analysis II: Types of recruitment

Previous studies suggested two classifications of sunsettia recruitment that increases the sunsettia population in the Golden Apple Archipelago.

Table 2: The two types of sunsettia recruitment

<b>Shoot recruitment</b>	Rooted shoots that originate from seed dispersal.
<b>Sprout recruitment</b>	Above-ground sprouts that arise from established stems.

During each data collection period, when tagging each new eligible sunsettia recruit, the ecologists noted down the corresponding method of recruitment. Figure 3 shows the mean density of sunsettia stems across all study sites differentiated by the method of recruitment.

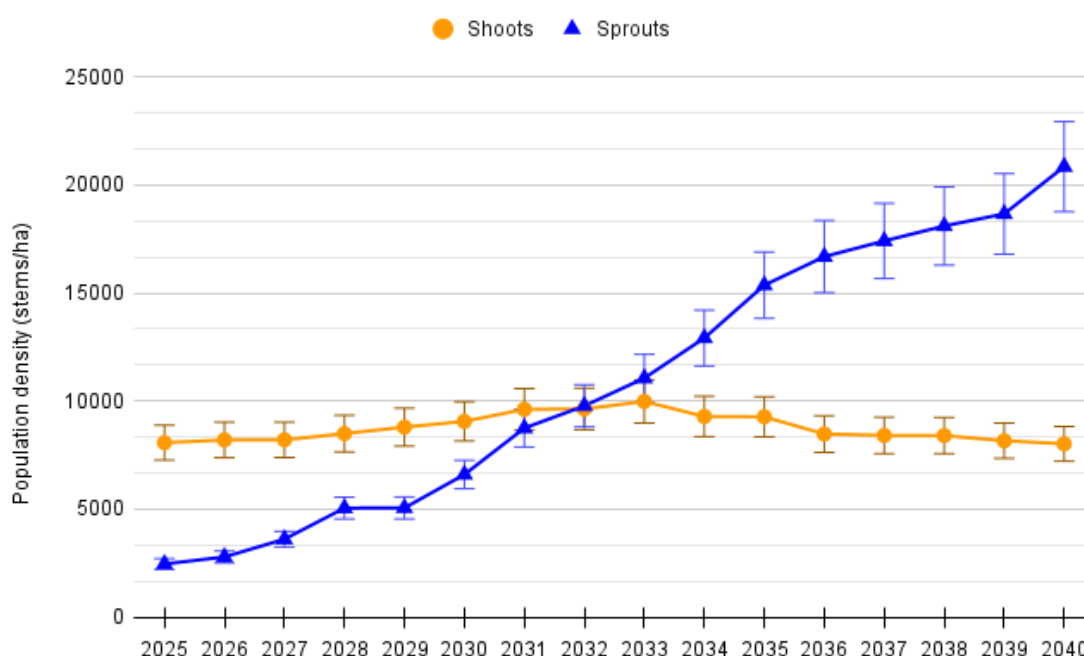

Figure 3: Mean density of shoots and sprouts across all study sites.

**Q5.** Indicate whether the following statements are true or false. **(40 points)**

*(Mark each statement as true or false.)*

- In a golden apple forest region on Pudding Isle that reported the first signs of sunsettia invasion in 2040, the sunsettia stems are likely to be shoots rather than sprouts.
- The average lambda for sunsettia shoots is approximately 0.
- If there is evidence that sunsettia sprouts have lower flowering rates than sunsettia shoots, then the ratio of sunsettia sporophytes to gametophytes increases across the study sites from 2025 to 2040.
- The rate of photosynthesis of a randomly selected sprout is greater than the rate of photosynthesis of a randomly selected and equally sized and aged shoot.

### Analysis III: Properties of the sunsettia

The sunsettia is a small, shade-tolerant tree that was introduced to the Golden Apple Archipelago more than 200 years ago. Even though its fruits are fleshy and edible, it quickly rots after ripening, subjecting the islands to several pest infestations throughout a sunsettia-dominated forest.

The sunsettia tree is apomictic and polyploid. It utilises two main methods of recruitment: seed dispersal and adventitious shoot development. Sunsettia seeds are mainly dispersed by wild pigs that feed on the sunsettia fruit.

Table 3: Types of spatial distribution.

<i>Interacting with golden apple trees:</i>	<b>Random</b>	<b>Aggregated</b>	<b>Uniform</b>
<b>Independent</b>	<i>A</i>	<i>B</i>	<i>C</i>
<b>Attracted</b>	<i>D</i>	<i>E</i>	<i>F</i>
<b>Repulsed</b>	<i>G</i>	<i>H</i>	<i>I</i>

**Q6.** Indicate the most likely spatial distribution of sunsettia stems at the study sites in 2025 and 2040 by entering a letter from Table 3 that represents the respective spatial distributions to each row. If you think that none of the distributions in Table 3 represent the most likely distribution, enter *J*. **(20 points)**

*(Enter the correct letter to each row.)*

<b>Year</b>	<b>Distribution (A-J)</b>
2025	
2040	

**Q7.** The polyploidy of the sunsettia is an evolutionary trait that was traced back to 500 years ago. Currently, throughout the world, diploid sunsettias have been outcompeted by polyploid sunsettias. Which of the following statements are possible reasons for this phenomenon? **(40 points)**

*(Select all correct options.)*

- A. Polyploid sunsettias have greater genetic diversity than diploid sunsettias.
- B. Polyploid sunsettias have a more efficient regulation of gene expression compared to diploid sunsettias.
- C. Polyploid sunsettias have a higher rate of beneficial mutations than diploid sunsettias.
- D. Polyploid sunsettias exhibit more extensive epigenetic modifications for more enhanced phenotypic plasticity than diploid sunsettias.
- E. Polyploid sunsettias contain more genes with functions that make polyploid sunsettias fitter than diploid sunsettias.
- F. Polyploid sunsettias carry fewer deleterious alleles, which makes them fitter than diploid sunsettias.
- G. Polyploid sunsettias have more advanced mechanisms for repairing DNA damage compared to diploid sunsettias.
- H. Polyploid sunsettias have a more accurate process of chromosome segregation than diploid sunsettias.
- I. Polyploid sunsettias benefit more from heterozygote advantages than diploid sunsettias.

Figure 4 shows several diagrams of reproductive structures in plants.

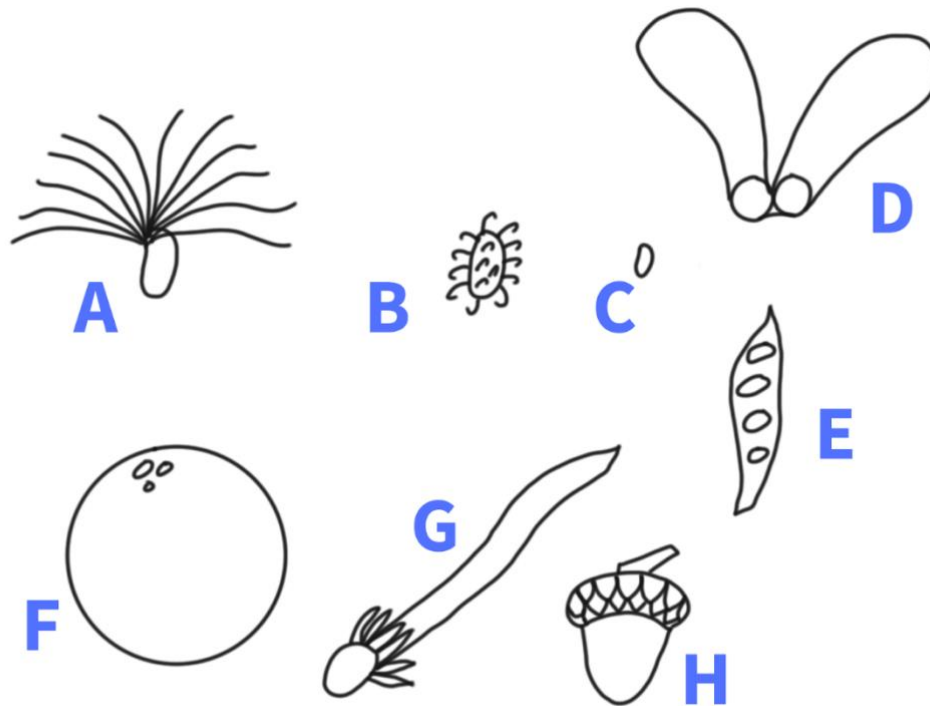

Figure 4: Diagrams of different possible sunsettia reproductive structures.

**Q8.** Which two reproductive structures most likely belong to the sunsettia plant? **(20 points)**  
(Select all correct options.)

- A. A
- B. B
- C. C
- D. D
- E. E
- F. F
- G. G
- H. H

# P16: Malicious Malicia's Malaria Magnum Opus I

(150 points)

Malaria is caused by a protozoan parasite belonging to the *Plasmodium* genus. Malaria is caused by a protozoan parasite belonging to the *Plasmodium* genus. The genus *Plasmodium* belongs to the phylum Apicomplexa. Nearly all apicomplexans possess the apicoplast, a special type of organelle. Figure 1 shows a *P. falciparum* parasite infecting a red blood cell.

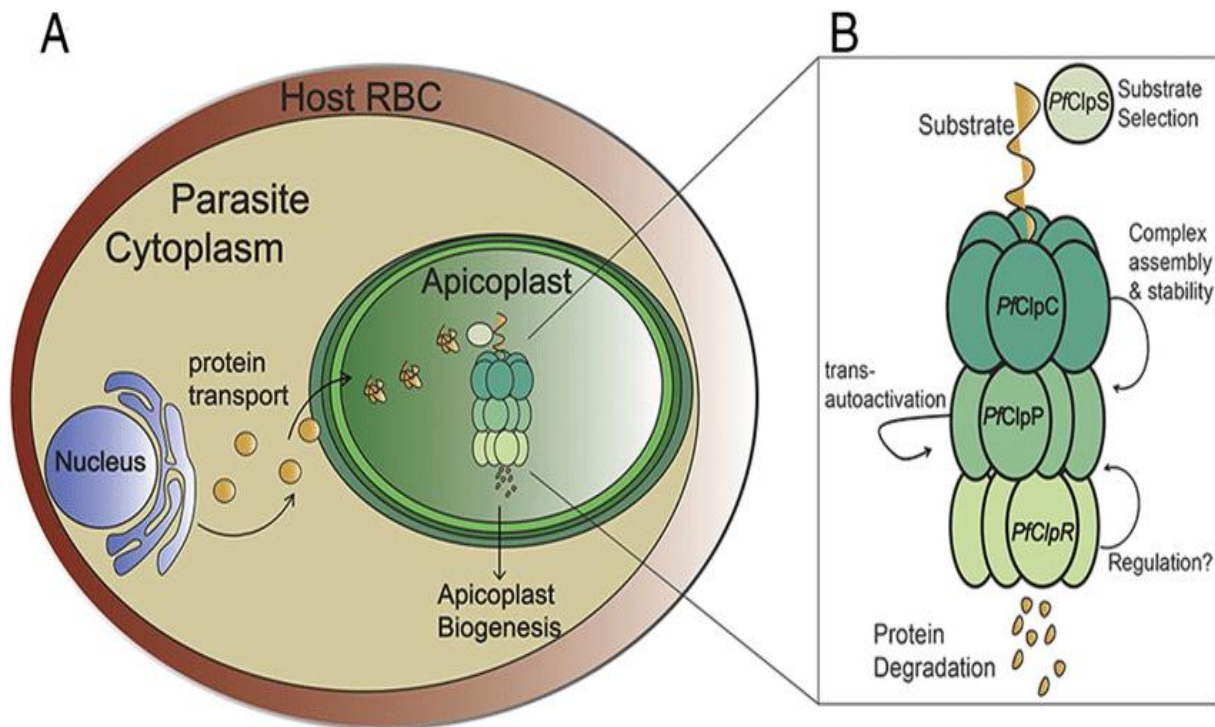

Figure 1: Diagrammatic representation of the *P. falciparum* parasite.

To qualify and stage, flow cytometry is a technique used. The sample containing infected red blood cells is treated and injected into a flow cytometer instrument, where cells pass through a column single file in ideal situations. The column is equipped with a laser which strikes each cell, and the scatter can be analysed to provide information about the physical and chemical characteristics of the cell.

A basic flow cytometry setup is depicted in Figure 2.

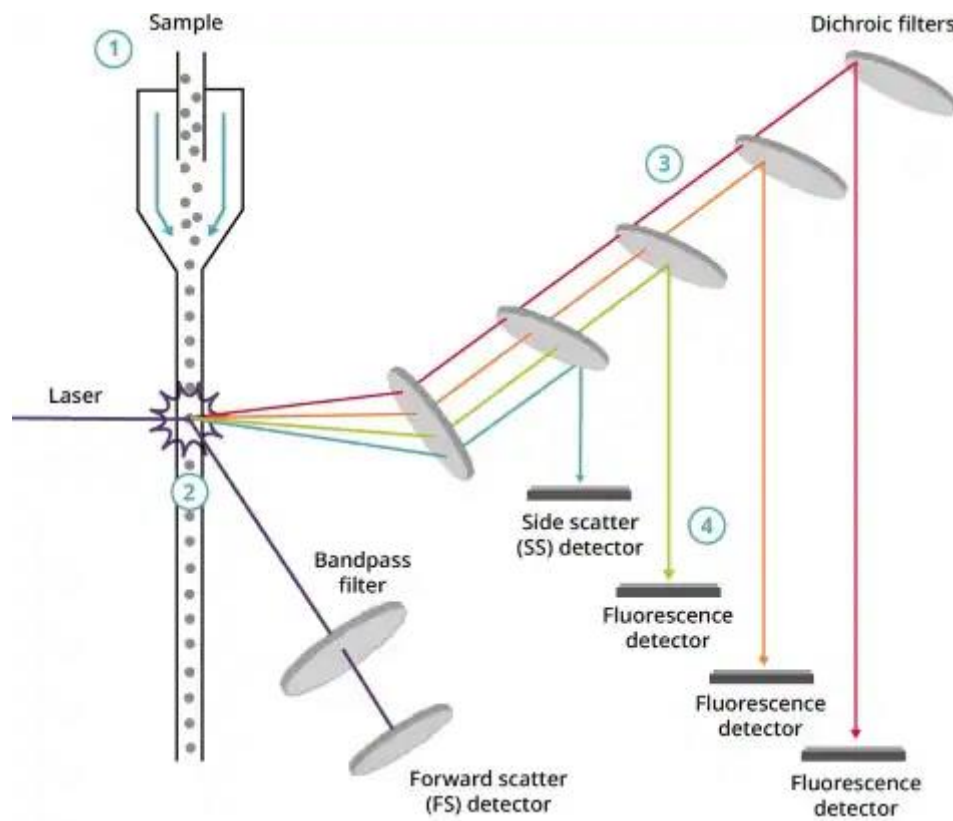

Figure 2: Basic flow cytometry setup

Forward scatter (FSC) and side scatter (SSC) are two parameters measured in flow cytometry. Forward scatter indicates the relative size of the cell, while side scatter indicates the complexity or granularity of the cell.

You are provided with fresh whole blood from a patient infected with *Plasmodium falciparum*. The cell populations present are **infected red blood cells (iRBC)**, **uninfected red blood cells (uRBC)**, **uninfected reticulocytes (uRTIC)** and **white blood cells (WBC)**. Debris is also present. Your task is to calculate the parasitaemia of this patient.

$$Parasitaemia = \left( \frac{iRBC}{total\ mature\ RBC} \right) \times 100\%$$

To zone in on your cell population(s) of interest, a process called gating is carried out, where cell populations **not** of interest are identified and excluded in a step-by-step manner – think of it as shortlisting.

The first step is usually to exclude cell debris. After excluding cell debris, the remaining cell populations are plotted with Hoechst vs CD45-APC as the two axes. Hoechst is a stain that the sample is treated with before it undergoes flow cytometry, and a positive Hoechst result indicates the presence of DNA while a negative Hoechst result indicates the absence of DNA. CD45 is an antigen that is found on the surface of nucleated hematopoietic cells.



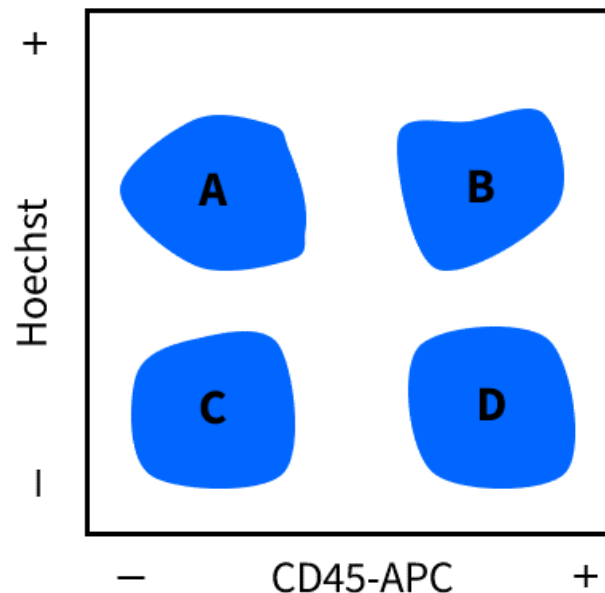

Figure 3: Flow cytometry results, testing for Hoechst and CD45.

Four clusters (A, B, C, D) are therefore possible due to the four possible combinations of Hoechst-/+ and CD45-/+ , as shown in Figure 2.

**Q1.** Which clusters would each of the cell populations (iRBC, uRBC, uRTIC, WBC) fall into? Note that it is possible for different cell populations to be represented in the same cluster, and not all clusters may be represented by a cell population. **(40 points)**

*(Enter the correct letter to the correct row.)*

Cell Population	Cluster
iRBC	
uRBC	
uRTIC	
WBC	

After analysis, you obtain these numbers:

Cell Type	Population Size/millions
iRBC	0.3
uRBC	8.9
uRTIC	0.8
WBC	8.0

**Q2.** Calculate the parasitaemia of the patient based on the above data. **(20 points)**

*(Enter your answer as a percentage correct to 3 s.f. Do not include the percent (%) sign.)*

When flow cytometry is unavailable, parasitaemia can also be estimated by doing a thin blood smear and viewing it under a microscope. It is assumed that the distribution of iRBC throughout the slide is uniform. The iRBC and total mature RBC from several microscope fields are counted. For this question, let us just use one microscope field.

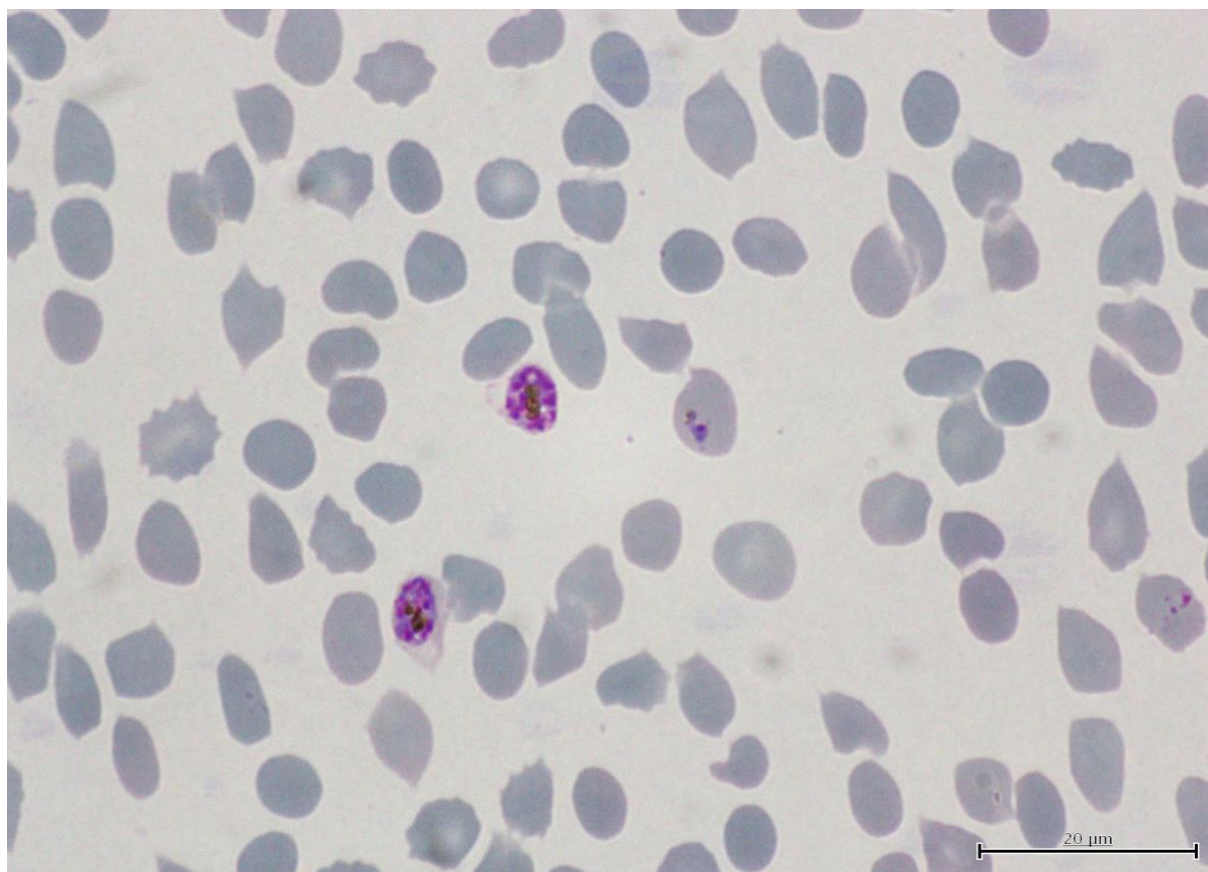

Figure 4: Thin blood smear of a *P. falciparum* culture, one microscope field.

Parasites appear purple and the red blood cells appear grey.

**Q3.** Calculate the parasitaemia based on the microscope field in Figure 4. For RBCs that are on the edge of the field and partially out of the field, count the ones on the left-hand side and top side of the field, but exclude the ones on the right-hand and bottom sides of the field. **(30 points)**

*(Enter your answer as a percentage correct to 3 s.f. Do not include the percent (%) sign.)*



*Plasmodium* parasites convert excess haem, which is toxic to the parasite, to haemozoin which is stored in a vacuole. Magnetic Activated Cell Sorting (MACS) is a method used in many *Plasmodium* studies. A parasite culture containing infected RBCs is passed through a column of magnetic beads.

**Q4.** Indicate whether the following statements are true or false. **(40 points)**

*(Mark each statement as true or false.)*

- A. Gating is unable to exclude data from several cells passing through the laser beam simultaneously.
- B. Debris is identified through its low FSC values.
- C. uRBC is present in the MACS eluent.
- D. iRBC is retained in the MACS column.

**Q5.** What is the purpose of MACS? **(20 points)**

*(Select all correct options.)*

- A. To enrich and isolate the iRBC
- B. To increase rate of infection so more uRBC becomes iRBC for analysis
- C. To induce eddy currents to elute the haemozoin
- D. To magnetise the *Plasmodium* parasites for extraction from iRBC
- E. To separate total RBC from WBC
- F. To measure haem content in RBC

# P17: This problem is a bully

(170 points)

Figure 1 shows a section of Plant A.

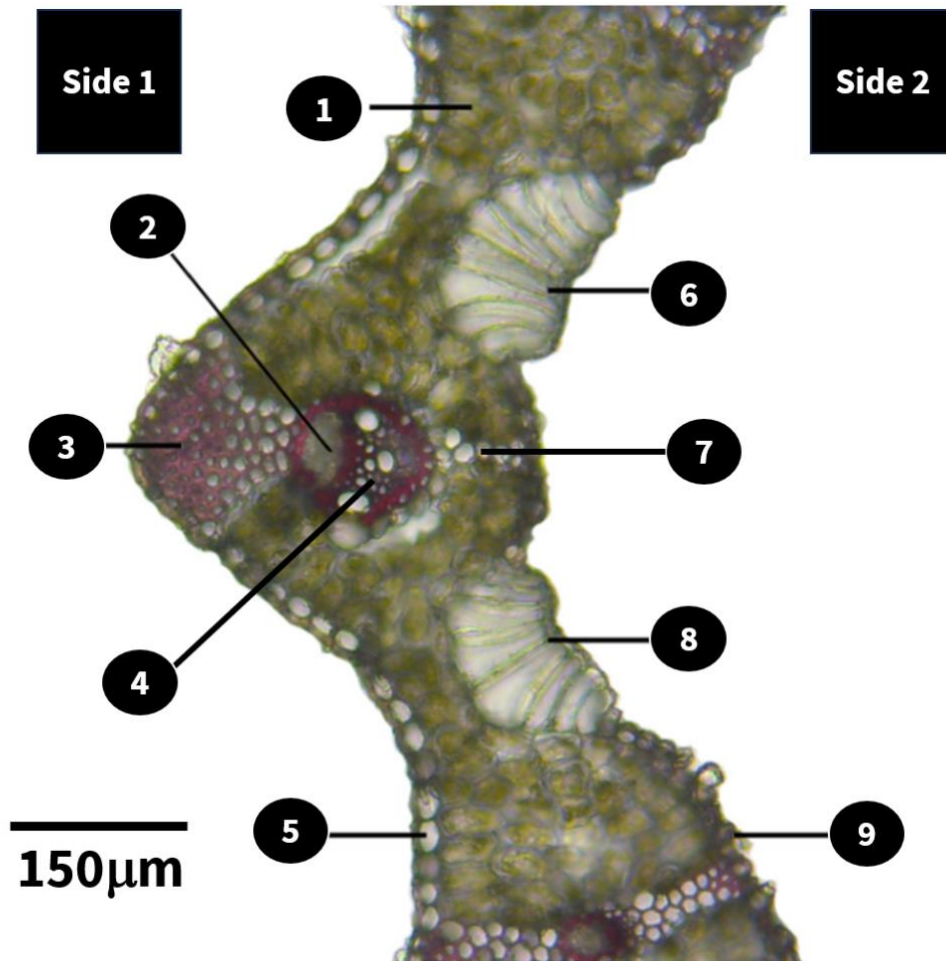

Figure 1: Plant A section.

**Q1.** Indicate which plant organ Figure 1 belongs to. (10 points)

*(Enter the correct word or phrase. Do not pluralise.)*

**Q2.** Indicate which of the following statements are true or false. (50 points)

*(Mark each statement as true or false.)*

- A. Side 1 represents the abaxial side.
- B. Figure 1 represents a mesophyte.
- C. Figure 1 is a longitudinal section.
- D. The stem of Plant A likely has no pith.
- E. Structure 7 is likely along the midrib.

**Q3.** Match the numbers of the structures (1-9) in Figure 1 to the following descriptions. If there is no such structure or process, type None. If there is more than one answer, type in all possible answers in numerical order without space or punctuations in between. **(40 points)**

*(Enter the correct numbers to the correct rows. If there is more than one possible number, enter all correct numbers in numerical order.)*

Description	Number
Presence of lignin	
Chlorenchyma	
Trichomes	
Transports mineral salts	

**Q4.** Indicate whether of the following statements regarding the plant in Figure 1 are true or false.

**(50 points)**

*(Mark each statement as true or false.)*

- A. Stratified columnar mesophyll is present.
- B. There are high levels of photorespiration at high temperatures such as 35°C.
- C. There are high activity levels of PEP carboxylase in bundle-sheath cells.
- D. RuBisCO is more complementary in conformation and charge to carbon dioxide in this plant than in most plants.
- E. Optimum temperature for photosynthesis is 30 to 40°C.

**Q5.** Which of the following most accurately represents the approximate area of the phloem vascular bundles in Figure 1? **(20 points)**

*(Select the correct option.)*

- A. 0.000955 mm<sup>2</sup>
- B. 0.00172 mm<sup>2</sup>
- C. 0.00612 mm<sup>2</sup>
- D. 0.0188 mm<sup>2</sup>
- E. 0.187 mm<sup>2</sup>
- F. 1.91 mm<sup>2</sup>
- G. 194 μm<sup>2</sup>
- H. 1210 μm<sup>2</sup>
- I. 11 700 μm<sup>2</sup>
- J. 1.00 m<sup>2</sup>

# P18: Training in the Avidya Forest

(190 points)

**Population genetics** is a field of biology that studies the distribution of allele frequencies within and between populations of organisms. Rather than looking at the cellular level (in the case of molecular genetics) or individual level (in the case of classical genetics), population genetics focuses on the bigger picture — how the overall distribution of traits changes within collections of individuals.

Inheritance is random in nature. For example, the allele for a particular gene in a diploid organism is passed down from parent to offspring in a 50-50-coin flip. However, through a macroscopic lens, these random events provide data for statistical inferences, which can then be applied to make predictions about the overall nature of a particular genetic trait.

In this problem, you will be sent to the Avidya Forest to learn population genetics from a trained researcher, Tighnari. Tighnari will guide you through two lectures before putting your skills to the test in a case study.

---

## Tighnari's Lecture, Chapter 1: Hardy-Weinberg equilibrium



Figure 1: Godfrey Harold Hardy (1877-1947), a statistician who studied population genetics

The **Hardy-Weinberg equilibrium** is a fundamental principle in the study of population genetics. A population is said to be in Hardy-Weinberg equilibrium if there are no evolutionary influences acting upon the population, such as natural selection or genetic drift. When a population is in Hardy-Weinberg equilibrium, both the **allele** and **genotype frequencies remain constant** from generation to generation.

Allele and genotype frequencies, being frequencies, are independent of population size. Hence, changes in population size are not an evolutionary influence and do not violate the Hardy-Weinberg principle.

In reality, no population is in perfect Hardy-Weinberg equilibrium. However, we can still use this principle to make inferences when a population is *near* Hardy-Weinberg equilibrium.

## Tutorial, Chapter 1

A population of creatures, the Spinocrocodile, have three different eye colours: white, red, and pink. Eye colour is controlled by one gene with two alleles ( $R/r$ ) that are incompletely dominant.

- Genotype  $RR$ : Red eye colour
- Genotype  $Rr$ : Pink eye colour
- Genotype  $rr$ : White eye colour

Tighnari had commissioned an ecologist to study the population of the Spinocrocodile. However, when he received the report, part of the report was damaged by water and the ink smudged.

Eye colour	Red	Pink	White	Total
Number	???	???	144	400

**Q1.** Assuming the Spinocrocodile population is and had been in Hardy-Weinberg equilibrium for at least the past generation, calculate the number of Spinocrocodiles in the population that have red eyes and pink eyes respectively. **(20 points)**

*(Enter your answers correct to the nearest whole number.)*

Colour of Eyes	Number
Red	
Pink	

## Tighnari's Lecture, Chapter 2: Chi-squared test

A statistical tool we can use to determine if observed data is statistically different from our calculated expectations is the **chi-squared test**.

$$\chi^2 = \sum \left[ \frac{(o - e)^2}{e} \right]$$

The **chi-squared value** can be calculated as the sum of  $\frac{(o-e)^2}{e}$  for each phenotype, where  $o$  and  $e$  are the observed data and expected data respectively. For example, if the number of white-fur mice observed is 40 when it was expected to be 50,  $\frac{(o-e)^2}{e} = \frac{(40-50)^2}{50} = 2$ .

Depending on the degrees of freedom, the chi-squared value can be converted to the **probability** (also known as the P-value) that one obtains data as extreme as your data. Hence, this indicates the probability that the discrepancy in the data is due to chance. In research, a small probability indicates a statistically significant result. In biology, most researchers use a critical P-value of 0.05.

## Tutorial, Chapter 2

A population of creatures, the Rishboland Tiger, has three sideburn lengths: long, dwarf, and no sideburn. The gene controlling sideburn length has two alleles with incomplete dominance, where the no sideburn allele  $N$  is dominant to the long sideburn allele  $n$ .

In 2002, Tighnari collected data on the number of Rishboland Tigers with each sideburn length. The population of Rishboland tigers were in Hardy-Weinberg equilibrium. 20 years later, he collected data again on the same population of Rishboland Tigers to investigate whether the population is still in Hardy-Weinberg equilibrium.

Sideburn Length	Long	Dwarf	No sideburn
Number (2002)	3	54	243
Number (2022)	15	101	584

A chi-squared test was done to determine whether the population of Rishboland Tigers remained in Hardy-Weinberg equilibrium from 2002 to 2022. Several possible hypotheses are listed below.

- A. There are **no** significant differences between the phenotypic frequencies in the observed and expected data. Hence, the population **did not remain** in Hardy-Weinberg equilibrium from 2002 to 2022.
- B. There are **no** significant differences between the phenotypic frequencies in the observed and expected data. Hence, the population **remained** in Hardy-Weinberg equilibrium from 2002 to 2022.
- C. There are significant differences between the phenotypic frequencies in the observed and expected data. Hence, the population **did not remain** in Hardy-Weinberg equilibrium from 2002 to 2022.
- D. There are significant differences between the phenotypic frequencies in the observed and expected data. Hence, the population **remained** in Hardy-Weinberg equilibrium from 2002 to 2022.



**Q2.** Match the appropriate null and alternative hypotheses from the hypotheses (A-D) above. **(20 points)**

*(Match the correct letter to the correct row.)*

Hypothesis	Option (A-D)
Null hypothesis	
Alternative hypothesis	

**Q3.** State the chi-squared value. **(30 points)**

*(Enter your answer correct to 3 s.f.)*

**Q4.** The test was carried out with a significance level of 0.05. Indicate whether the following statements are true or false. **(40 points)**

*(Mark each statement as true or false.)*

- A. The null hypothesis should be rejected in favour of the alternative hypothesis.
- B. The population of Rishboland Tigers had evolved.
- C. The results of the chi-squared test show that natural selection selects against heterozygous genotypes for sideburn length in the population of Rishboland Tigers.
- D. The results could be explained by a sexual preference for partners with similar sideburn lengths in the population of Rishboland Tigers.

## Case Study: Eleazar

Good job sitting through the past two lectures! Tighnari believes that you are ready to assist him with his research. He tells you that the nation of Sumeru (which you are both in right now) had a major problem: there exists an incurable disease called Eleazar, which causes hard scales to form on the skin.

Tighnari had been researching this disease for many years, and he vowed to continue until, in his words, “Eleazar and all its notorious effects have been rid from this world.”

He slides over a stack of paper, and you see a pedigree on the front page (Figure 2). “The first case, many centuries ago,” he says indiscriminately, without a hint of expression on his face. “Unlucky fellow.”

Individual I-1 was recorded to be the **first case of Eleazar** in the country. Since then, the country had been on lockdown, so no one could enter in or out.

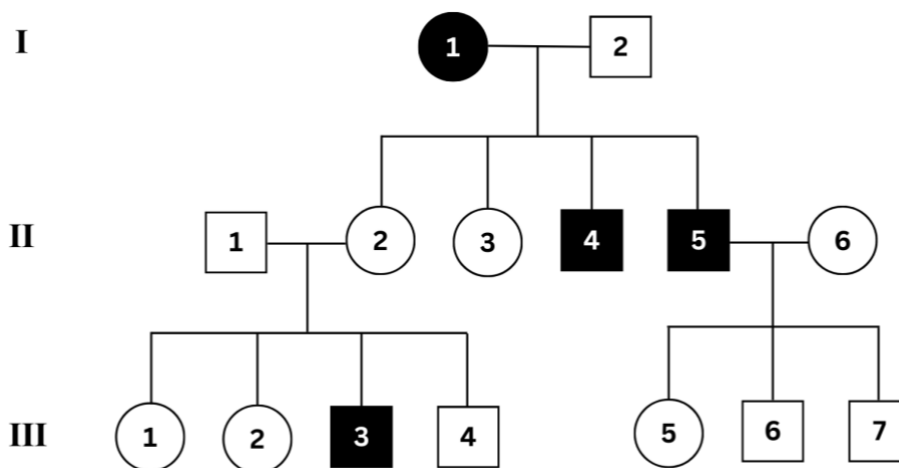

Figure 2: Pedigree

You flip the page and the table of data in Table 1. In the year 2024, Tighnari collected data from a sample of 1,840 people from Sumeru.

Table 1: Data from 1840 people in Sumeru

	Females	Males	Total
Afflicted with Eleazar	72	236	308
Total	920	920	1840

“Find anything?” Tighnari asks. You look at the table carefully, and something seems off. “Hold on a minute,” you say, “isn’t this a disproportionate fraction of males who are affected? That’s so unfair”

“Well, some variations here and there are expected when we collect data in reality, no?” he retorts.

You adamantly believe that that is not the case. “Seems like something more,” you reply, “but I’m not sure how to prove it.”

You decide to perform a chi-squared analysis to determine whether the number of males and females with Eleazar in the table significantly differs from the expected numbers should the disease affect both sexes equally. Your calculated results are seen in the table below.



### My First Eleazar chi-squared test

	Observed	Expected	$\frac{(o - e)^2}{e}$
Females with Eleazar	72	a	f
Females without Eleazar	848	b	g
Males with Eleazar	236	c	h
Males without Eleazar	684	d	j
		<b>Total:</b>	104.881

**Q5.** The test was carried out with a significance level of 0.05. Indicate whether the following statements are true or false. **(40 points)**

*(Mark each statement as true or false.)*

- A. The critical chi-squared value is 9.488.
- B. The probability that the discrepancy between the observed data and expected data is not due to random chance alone is extremely high.
- C. Value **a**, value **b**, value **c** and value **d** are equal.
- D. Value **f** and value **h** are equal.

Tighnari seems impressed with your work. However, his smile has all but vanished.

“Right, back to business,” he says, walking over to you, “because I have a report to send to *my* mentor. He’s asked me to extrapolate the nation’s current predicament and approximate the number of Eleazar cases twenty years from now.”

“What? Why?” You seem confused.

“Well, he’s working on some... treatment for Eleazar and wants to know how much time he has before the situation gets out of hand.” Tighnari’s face is grim.

“Isn’t it out of hand already?” But perhaps both of you already know the answer.

In any case, Tighnari has entrusted you with the final part of his report. Use the knowledge that he has passed to you prior and research well before submitting the calculations back to him.



**Q6.** With reference to Figure 2 and Table 1, calculate the proportion of females in the tribe that are heterozygous for Eleazar in the year 2044, assuming the population is in Hardy-Weinberg equilibrium, and that the relative fitness of individuals with Eleazar is 1. **(40 points)**  
*(Enter your answer correct to 3 s.f.)*

---

You slide your report to Tighnari. He takes a peek at your messy calculations, but seems content with it.

“Thank you, traveller. Now, we wait for next year.”

# P19: Malicious Malicia's Malaria Magnum Opus II

(140 points)

Malaria is caused by a protozoan parasite belonging to the *Plasmodium* genus. The genus *Plasmodium* belongs to the phylum Apicomplexa. Nearly all apicomplexans possess the apicoplast, a special type of organelle. Figure 1 shows a *P. falciparum* parasite infecting a red blood cell.

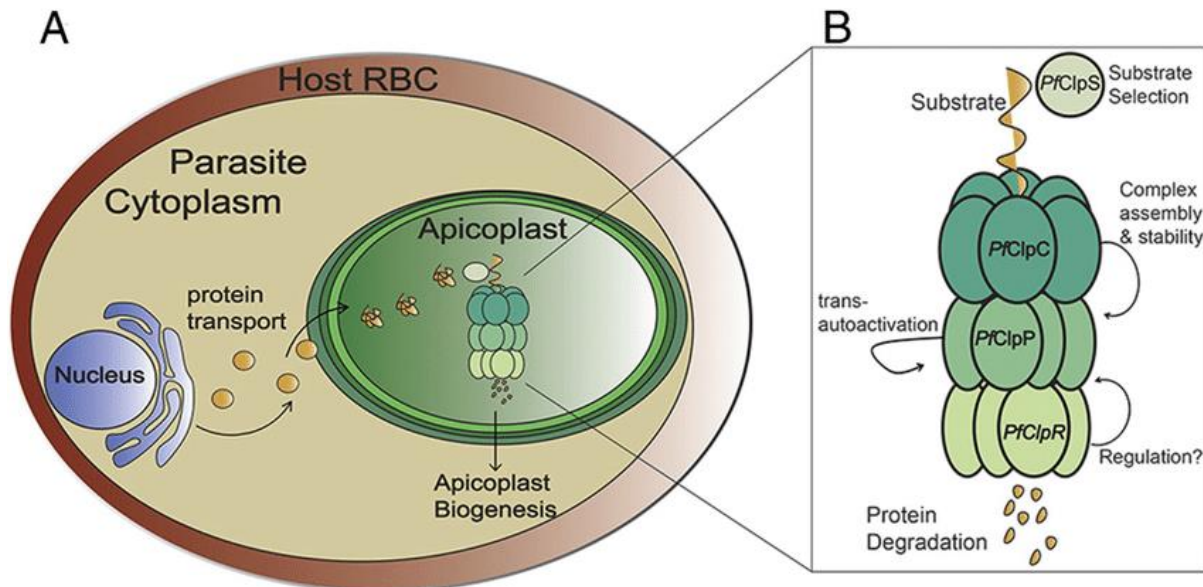

Figure 1: Diagrammatic representation of the *P. falciparum* parasite.

**Q1.** In terms of origin, which organelle is the apicoplast most similar to? (10 points)

(Select the correct option.)

- A. Ribosome
- B. Chloroplast from land plants
- C. Chloroplast from brown algae
- D. Mitochondria
- E. Amyloplast
- F. Lysosome

**Q2.** Indicate whether the following statements are true or false. (40 points)

(Mark each statement as true or false.)

- A. When the apicoplast is isolated, processed and run through gel electrophoresis, bands will appear when stained with ethidium bromide.
- B. The Clp complex in Figure 1 is only involved in lipolysis.
- C. *Plasmodium falciparum* is stained using the Ziehl-Neelsen acid-fast stain.
- D. More than one parasite can exist in an erythrocyte.

Figure 2 shows the life cycle of the parasite.

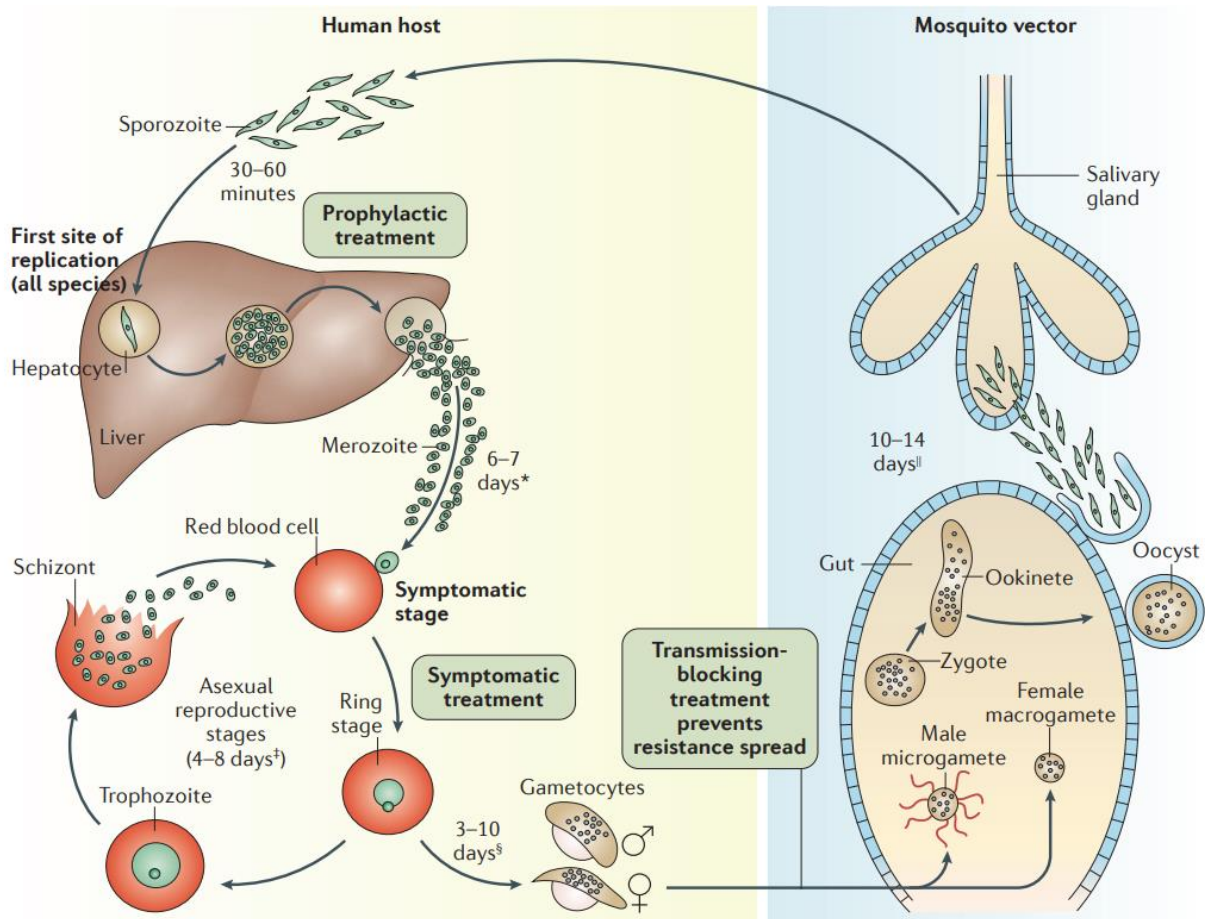

Figure 2: Diagram of the *P. falciparum* life cycle.

**Q3.** The apicoplast is essential to the survival of the Plasmodium parasite. One of the functions of the apicoplast is fatty acid synthesis. Select all the options that represent likely outcomes of disrupting this function of the apicoplast. **(20 points)**  
(Select the correct options.)

- A. The parasite will die immediately.
- B. The parasite is no longer able to invade the host red blood cells.
- C. The parasite will not be able to form merozoites at the liver stage.
- D. The parasite will no longer be able to be transmitted from host to vector.

**Q4.** Which parasite development stages would you expect to be able to see in an *in vitro* culture with red blood cells? **(30 points)**

(Select the correct options.)

- A. Sporozoite
- B. Merozoite
- C. Ring stage
- D. Trophozoite
- E. Schizont
- F. Gametocyte
- G. Zygote
- H. Ookinete

Four life stages of *P. falciparum* as seen under the microscope are labelled Images W-Z in Figure 3.

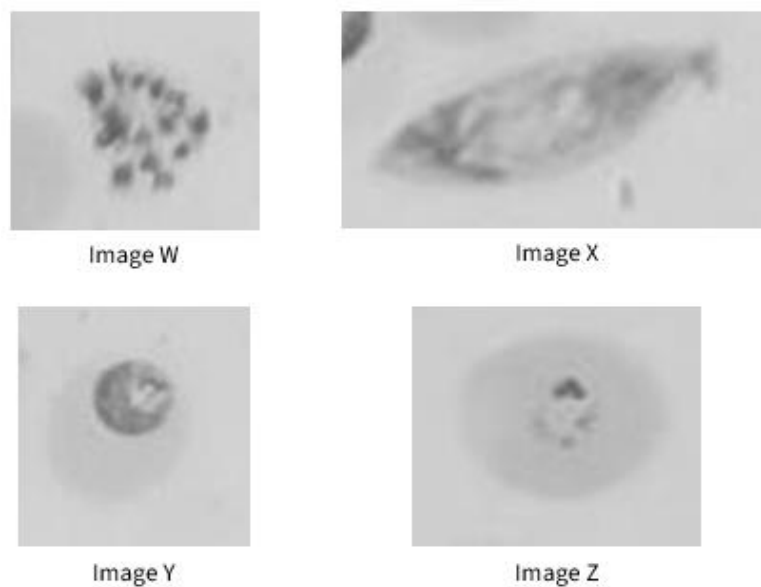

Figure 3: Life stages of *P. falciparum*

**Q5.** Match the images (W-Z) to their respective life stages. Use Figure 2 to aid you. **(40 points)**

(Enter the correct answer to each row.)

Image	Life Stage
W	
X	
Y	
Z	

# P20: Daddy Long Legs

(130 points)

Many metabolic reactions in the body involve condensation polymerisation, including DNA and polypeptides. In polymerisation reactions, two monomers are joined together with the removal of a small molecule (Figure 1). Thus, the mass of the polymer is less than the total mass of both the monomers due to the loss of the molecule.

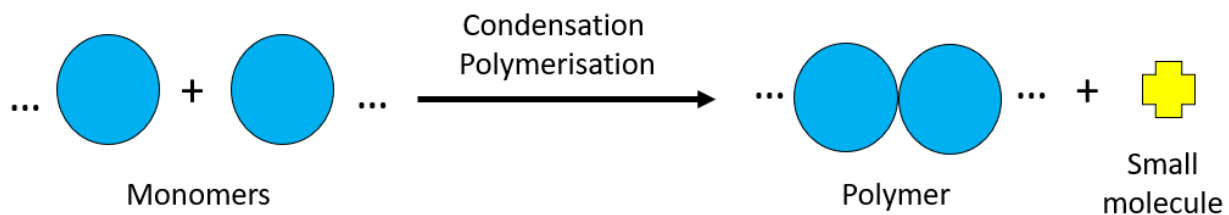

Figure 1: Condensation Polymerisation

**Q1.** Indicate which of the following biological processes are descriptions of **condensation polymerisation**. (30 points)

(Select all correct options.)

- A. Formation of tRNA in the nucleus
- B. Complementary base pairing between DNA strands to form a DNA double helix
- C. Water forming a continuous stream in the xylem for transpirational pull
- D. Formation of cellulose by cellulase
- E. Formation of lipids by joining of fatty acids and glycerol
- F. Formation of amylopectin in plant cells
- G. Aminoacyl-tRNA synthetase joining amino acid to tRNA molecule
- H. Formation of keratin in hair
- I. Blood coagulation by platelets and plasma proteins
- J. Binding of insulin to the insulin receptor
- K. Methylation of DNA

Luke is already familiar with polymerisation in proteins, and is thus curious to understand more about polymerisation in nucleic acids. He is curious about the changes to the DNA helix structure when the nucleobases are changed.

Luke modified several nucleobases found in nucleic acids and produced deoxysulfuric dihydronine triphosphate (dSTP), deoxyttrbiumine triphosphate (dYTP), deoxyjeromine triphosphate (dJTP), and deoxylimomethylene triphosphate (dLTP). These four molecules are the deoxyribonucleoside triphosphates (dNTP) of S, Y, J and L respectively. L is similar to cytosine as both can be methylated by methyltransferase. S (pyrimidine) base pairs with Y (purine) and J (pyrimidine) with L (purine). These





dNTP molecules are known to polymerise in the same manner as dATP, dCTP, dGTP, and dTTP to form nucleic acids.

**Q2.** How many different DNA triplets (forming mRNA codons) can be produced by these 4 modified nucleobases (S, Y, J, L) and the four canonical nucleobases (A, T, G, C), assuming that at least one nucleobase must be either S, Y, or J? **(20 points)**

*(Enter your answer correct to the nearest whole number.)*

Luke used these modified dNTPs to construct three different ssDNA strands. However, he does not know the identity of each dNTP molecule and thus labelled them A, B, C, and D. Their sequences and their mass can be seen below. The masses of the dNTP molecules and other relevant molecules are given below as well.

DNA strand	Sequence	Mass/g mol <sup>-1</sup>
1	ABDDCADBBABB	4221
2	CABADABABDD	3833
3	ABBACADABBAA	4205

Molecule	Mass/g mol <sup>-1</sup>
Methyl Group	15
Acetyl Group	43
Phosphate	95
Pyrophosphate	174
dSTP	490
dYTP	498
dJTP	521
dLTP	530

**Q3. Identify dNTP molecules A, B, C, and D. (40 points)**

*(Match the correct letter to the correct row.)*

dNTP	Label (A, B, C, D)
dSTP	
dYTP	
dJTP	
dLTP	

**Q4. Indicate whether the following statements are true or false. (40 points)**

*(Mark each statement as true or false.)*

- A. These DNA strands cannot be transcribed due to the lack of a start codon (AUG).
- B. If the ssDNA strands are base paired with their complementary strand forming a dsDNA molecule, their mass will be doubled.
- C. Methylation of limomethylene (L) in DNA strand 3 will cause a theoretical rise in mass of 56g for each mole of the DNA strand.
- D. If Luke creates a ssDNA strand where the percentage of J is 35%, the percentage of L will be 15%.

# P21: Trihybrid Trouble

(190 points)

A plant has three genes that influence the intensity of the colour of its petals. Let these genes have alleles  $A/a$ ,  $B/b$  and  $C/c$ . They have an additive effect as such:

- $AA$ ,  $BB$  or  $CC$  contribute 4 units of pigment each
- $Aa$ ,  $Bb$  or  $Cc$  contribute 2 units of pigment each
- $aa$ ,  $bb$  or  $cc$  contribute 1 unit of pigment each

Hence, a plant with genotype  $AabbCc$  would have petals with 5 units of pigment in them whereas another flower with genotype  $AABBcc$  would have 9 units of pigment in its petals. To get the ball rolling and the flowers blooming, we first cross two flowers with genotype  $AaBbCc$ . (*Hint: You can use Excel to create three Punnett squares, each measuring the effect of each of the three genes, and then add them up to get the final distribution.*)

**Q1.** Which genotype-phenotype relation matches the above scenario the best? (10 points)

(Select the correct option.)

- A. Complete dominance
- B. Incomplete dominance
- C. Codominance
- D. Overdominance
- E. Underdominance

**Q2.** Indicate the number the units of pigment in the flower petals of plants with the following genotypes. (30 points)

(Enter a whole number to each row. Do not include any units.)

Genotype	Amount of pigment/units
$AaBBCC$	
$Aabbcc$	
$aabbcc$	

**Q3.** How many possible genotypes would result from the cross? (10 points)

(Enter a whole number.)

**Q4.** Which of the following units of pigment would be modal? **(30 points)**

*(Select all correct options.)*

- A. 1
- B. 2
- C. 3
- D. 4
- E. 5
- F. 6
- G. 7
- H. 8
- I. 9
- J. 10
- K. 11
- L. 12

**Q5.** If we keep picking flowers from the offspring of the cross, what would be the average pigment value? The value need *not* be a whole number. **(30 points)**

*(Enter your answer correct to 3 s.f.)*

Suddenly, the plant's pollinators go near blind and cannot see any flowers whose petals have 9 units of pigment or fewer. You should assume they have an equal chance of landing on any flower they can see and will pollinate said flower.

**Q6.** What is the probability of the pollinator landing on a flower with 12 units of pigment in its petals? **(10 points)**

*(Enter your answer as a decimal correct to 3 s.f.)*

**Q7.** Which of the following plant genotypes have flowers that the pollinator can see and hence land on? **(10 points)**

*(Select all correct options.)*

- A. Triple homozygous dominant
- B. Triple heterozygous
- C. Triple homozygous recessive

Wanting to study the pigment more, we extract it from the petals and make a solution. We put the solution into the spectrophotometer in cuvettes of 1-cm width and collect the following data:

Genotype	Absorbance/a.u.
<i>AABBCC</i>	0.891
<i>AABbCC</i>	0.750
<i>aaBbCc</i>	0.364
<i>aabbcc</i>	0.222

**Q8.** If we want to model the above values in a graph of absorbance against the number of pigment units with a best-fit straight line, what would its gradient be? **Enter your answer correct to 2 s.f. (20 points)**

(Enter your answer correct to **2 s.f.**)

Where necessary, use the **2 s.f. values of the gradient and y-intercept** of the equation of the graph you obtained in **Q8** to solve the following questions.

The Beer-Lambert Law is used in spectrophotometry to determine the concentration of a light-absorbent species. The formula is seen below:

$$A = \epsilon cl$$

Where  $A$  refers to absorbance,  $\epsilon$  is the molar extinction coefficient ( $\text{M}^{-1} \text{cm}^{-1}$ ),  $c$  is the concentration of the species ( $\text{M}$ ), and  $l$  is the length of solution that the light passes through the cuvette ( $\text{cm}$ ).

**Q9.** The solution obtained from the plant with genotype *aabbcc* is found to have a concentration of 0.08M. Assuming that we are using cuvettes of 1 cm width, use the Beer-Lambert Law to find the molar extinction coefficient in  $\text{M}^{-1} \text{cm}^{-1}$ . **(20 points)**

(Enter your answer correct to 3 s.f.)



**Q10.** A careless student over-dilutes the pigment solution extracted from the flower petals of a plant with genotype  $aaBBCc$ . He obtains an absorbance value of 0.174. How many times was the solution diluted? **(10 points)**

*(Select the correct option.)*

- A. 10x
- B. 8x
- C. 5x
- D. 4x
- E. 3x
- F. 2x

**Q11.** What would the expected absorbance value be from the solution extracted from a flower belonging to a plant with genotype  $AAbbCC$ ? **(10 points)**

*(Enter your answer correct to 3 s.f.)*

## P22: Bend it like Bee-ckham

(230 points)

From your education in the Regnia Symposium, you have learnt about how scout honeybees perform a waggle dance when they find a location with nectar and pollen or a new nest site. The dance conveys information regarding the distance and direction of the location. An explanation of the waggle dance is given in Figure 1, so as to refresh your memory.

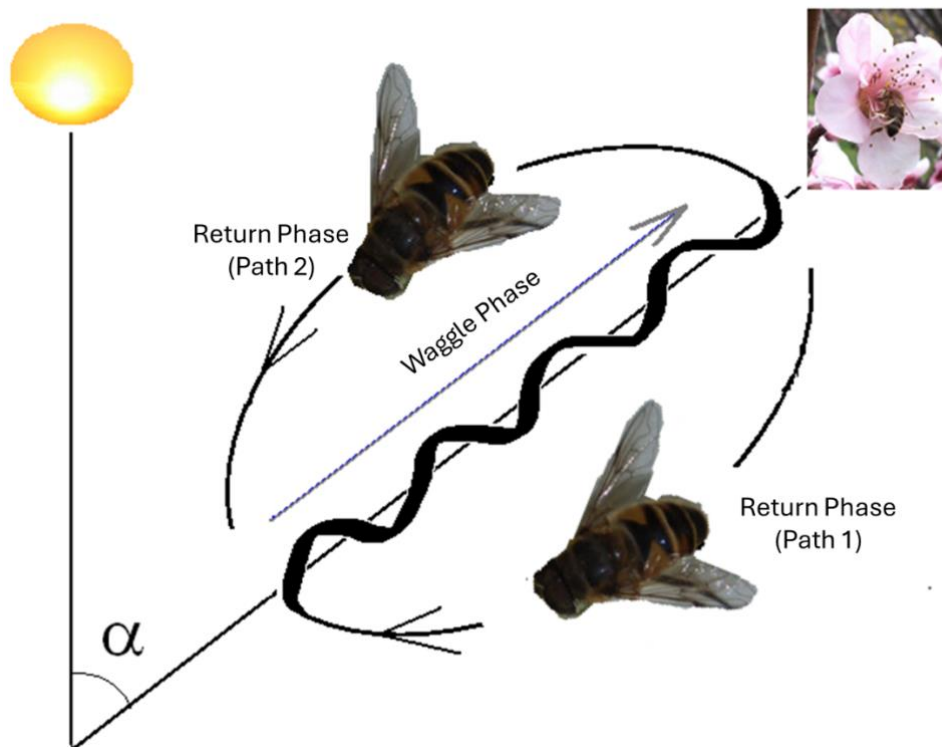

Figure 1. A diagram of the waggle dance performed by honeybees

The dance can be divided into two parts: the waggle phase and the return phase. The waggle phase is the actual part of the dance that encodes information about the location. Firstly, the dance is done on the vertical plane of the honeycomb, with upwards being the sun's position at that time of the day. The angle of the waggle phase denotes the relative angle of the location with respect to the sun, represented in Figure 1 by  $\alpha$ . Secondly, the duration of the waggle phase encodes the distance. It is generally agreed that 0.1s of waggle duration correlates with around 100 metres in distance.

Now, you have been called to the planet Arrakis by St. Alia of the Knife, a psychic with a soft spot for zoology, to study some of the native animals and characterise them. On the spaceship from your home planet to Arrakis, you were given the following information about the first animal you have to study, the Flutters:

*To try and get away from the Harkonnen soldiers, the Shai-Hulud worms on the planet have evolved the ability to fly. They are colloquially referred to as the Flutters by the Imperial Planetologists governed by House Atreides. There are two species (both capable of flight) and each has its own extant population, one in the North Frontier and the other in the South Frontier. Both populations have only one Queen, whereas all the other Flutters and their offspring can be Scouts. The ancestral population was split into two roughly genetically similar groups (the North Frontier population and the South Frontier population) after the Lord of the Earth struck upon Arrakis and erected a chain of Pillars using the secret Otherworldly Spell of **Dominus Lapidus**. Over time, the two populations have ended up as two distinct species.*

*After this separation, only the Flutters of the North Frontier evolved the distinctive Fluttwerk dance. This dance is a spectacle, usually performed by a Scout Flutter in front of the Queen Flutter. The energetic dance frequently summons sandstorms, so the Fremen cry out the phrase **pardana itha** (which means ‘duststorm comes’ in their native tongue) just before the Scout Flutter commences the Fluttwerk.*

*The Flutters, like their ancestors, are fiercely territorial. They can sense the presence of foreigners in their land and frequently attack them in retaliation. This means spice harvesters and rogue Harkonnen soldiers (who escaped the Holy War waged by Paul Atreides upon the alliance of Houses Harkonnen and Corrino) regularly incur the wrath of these otherwise docile animals. However, their own is lost in the process. Provided are some resources gathered by the native Fremen during their spice expeditions that can offer more information about the Flutters.*

Population	Habitat area/km <sup>2</sup>	Population size	Number of predators or enemies	Number of prey	Water availability/m <sup>3</sup> water
Ancestral population	545,600	8246	12,504	45,014	400,000
North Frontier population	326,500	4935	23,965	26,940	239,370
South Frontier population	219,100	3311	4,895	18,074	160,630



You are assured that the number of predators or enemies, number of prey and water availability has remained fairly constant throughout time and the values given are the mean of all annual measurements taken for the population ever since their existence. The population size of the ancestral population was measured at its peak, right before the split. The population size of the North Frontier and South Frontier populations was taken right after the split.

**Q1.** Which of the following is the most likely evolutionary pressure behind the evolution of the Fluttwerk behaviour in the North Frontier population? **(20 points)**  
(Select the correct option.)

- A. Decreased per capita water availability ( $\text{m}^3/\text{no. of individuals}$ )
- B. Increased predator or enemy density ( $\text{no. of predators or enemies}/\text{km}^2$ )
- C. Decreased prey density ( *units redacted* )
- D. Increased prey density ( *units redacted* )
- E. Increased intra-population competition for space ( *units redacted* )
- F. Increased intra-population competition for prey ( $\text{no. of prey}/\text{no. of individuals}$ )
- G. Decreased water availability ( $\text{m}^3/\text{km}^2$ )

Several possible graphs for the number of mortalities per 1000 individuals per week over 4500 years are given in Figure 2.

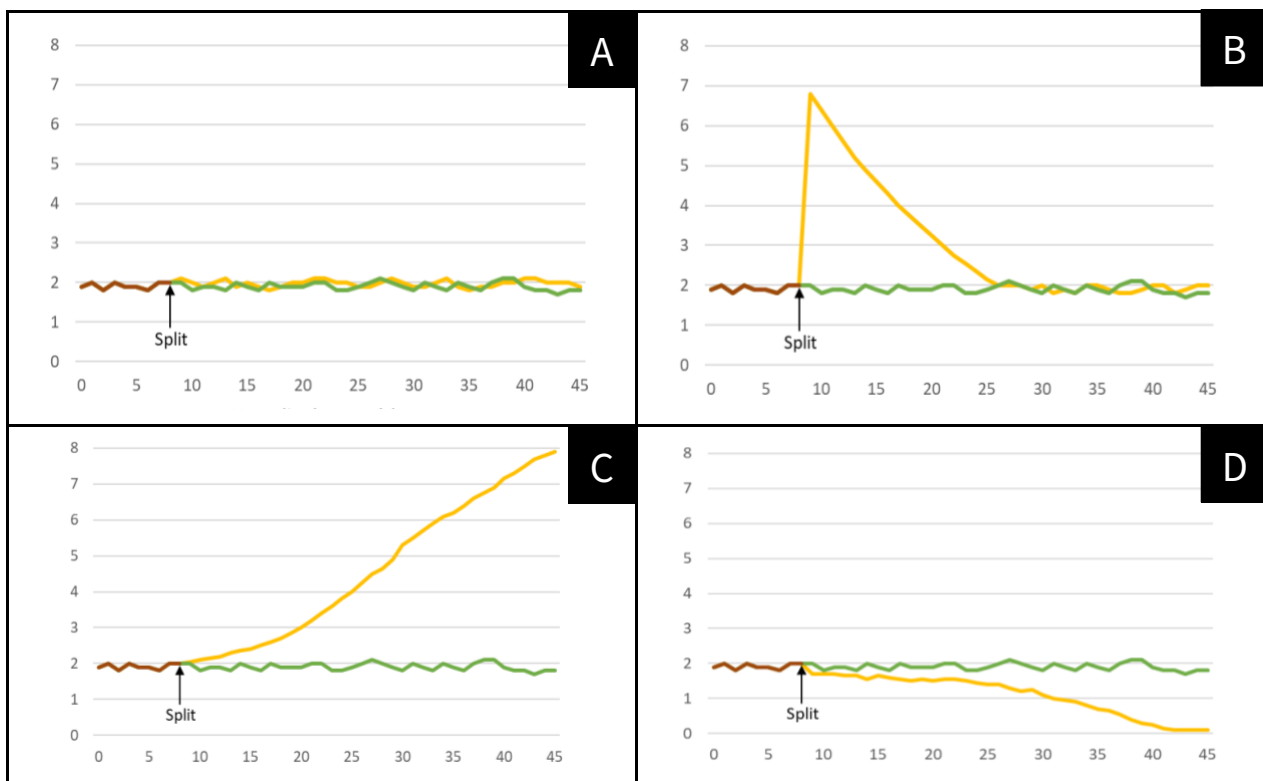

Figure 2: Possible graphs of number of mortalities per 1000 individuals per week over 4500 years. y-axis represents number of deaths per week per 1000 individuals. x-axis represents the year in thousands. Yellow line: North Frontier, Green line: South Frontier, Brown line: Ancestral population. The point of splitting of the ancestral population is indicated with an arrow.

**Q2.** Based on Figure 2, what is the most plausible graph for the annual number of mortalities in the population? **(10 points)**

*(Select the correct option.)*

- A. A
- B. B
- C. C
- D. D

**Q3.** Which type of speciation mechanism fits that of the Flutters the best? **(10 points)**

*(Select the correct option.)*

- A. Allopatric Speciation
- B. Parapatric Speciation
- C. Peripatric Speciation
- D. Sympatric Speciation

**Q4.** Match the species concepts to the *possible* observations you can make of the Flutters. **(40 points)**

*(Match the correct number to the correct row.)*

- 1. Biological
- 2. Ecological
- 3. Morphological
- 4. Phylogenetic

Observation	Species Concept (1-4)
The two species prey on different organisms and inhabit geographically separate areas.	
Only the North Frontier species has evolved the Fluttwerk, which makes it an apomorphy.	
The two species produce infertile offspring when cross-reproducing.	
The North Frontier species have a different pattern on their scales and wings as compared to the South Frontier species.	



After reading all the information provided and consolidating your understanding, your superior tasks you to understand the Fluttwerk. The characteristics of the Fluttwerk that can be varied are the duration of the dance, which way the abdomen of the Scout Flutter points during the dance and which wing is fluttered.

Many brilliant graduates of the Regnia Symposium have tried and failed at this task, so you set your mind to be the first one to crack this secret the Flutters hold. However, the Fremen used to revere the Shai-Hulud and hence hold their descendant Flutters in high regard. As a result, you are strictly forbidden from keeping them captive and using them as experimental subjects. To understand the Fluttwerk better, you only have data of past fights that the Fremen happened to notice. They are recorded in the Arrakis Annals found at the Imperial Library and your transcribed set of notes are below. Will this unlikely occurrence and the honeybee's waggle dance offer any clues? Only time will tell. Go forth and maybe, just maybe, the Regnia Symposium will laud you in the centuries to come.

Year of Fight	Individual Location	Fluttwerk Characteristic		
		Duration of Fluttwerk	Abdomen Pointing	Wing(s) fluttered
9922 AG*	4 spice harvesters due north, 200m away	30 seconds	Down	Right
9961 AG	10 spice harvesters due northeast, 100m away	30 seconds	Down	Right
10130 AG	2 Harkonnen soldiers due east, 150m away	10 seconds	Left	Left
10137 AG	1 Harkonnen soldier and 2 spice harvesters due southeast, 200m away	15 seconds	Left	Both
10147 AG	4 spice harvesters and 2 Harkonnen soldiers due south, 100m away	30 seconds	Down	Both
10148 AG	1 Harkonnen soldier and 1 spice harvester due southwest, 200m away	10 seconds	Right	Both
10152 AG	1 spice harvester due west, 50m away	5 seconds	Right	Right



10166 AG	5 Harkonnen soldiers and 3 spice harvesters due northwest, 150m away	30 seconds	Down	Both
10177 AG	3 Harkonnen soldiers due north, 50m away	15 seconds	Down	Left
10180 AG	5 spice harvesters due south, 100m away	30 seconds	Down	Right

\*AG refers to After Guild, with 0 AG being the year when the Spacing Guild successfully monopolised space travel. Before House Harkonnen took over Dune in 10130 AG, only spice harvesters were recorded as unfortunate victims of the Flutters.

**Q5. What do the Fluttwerk features represent? (40 points)**

(Match the correct number to the correct row.)

1. Duration of Fluttwerk
2. Direction the abdomen points in
3. Which wings are fluttered
4. Not coded for

Information regarding threat	Fluttwerk feature (1-4)
Type of intruder	
Number of intruders	
Distance of intruders	
Direction of intruders	

Your superior checks your hypothesis against all the recorded fights, and surprisingly it seems to hold up! Extremely well, in fact. You smile inwardly, proud of what you have achieved. The days seem to fly by incredibly fast... you now proceed to study the different plants around the desert and marvel at their adaptations in such an arid climate. One day, a Fremen group runs towards the camp your colleagues have set up. They're mumbling and gesturing wildly while behind you, there seems to be dust flying everywhere. And amidst this chaos you hear the words you thought you wouldn't in this lifetime, **'fardhana itha'**. Slowly, you piece together from what the Fremen tell you that 7 spice harvesters of Muad-dib's have entered the North Frontier from the southwest and were detected by the Scout Flutter 150m away. Your supervisor is too shocked to react but you, as a true science graduate of the Regnia Symposia, immediately get your sand-resistant and self-cooling writing pad out.

**Q6.** What would the Fluttwerk in the above case look like? **(30 points)**

*(Match the correct number to the correct description.)*

1. 5s
2. 10s
3. 15s
4. 20s
5. 25s
6. 30s
7. 35s
8. Abdomen pointing down
9. Abdomen pointing left
10. Abdomen pointing right
11. Abdomen pointing up
12. Only left-wing fluttering
13. Only right-wing fluttering
14. Both wings fluttering
15. No wings fluttering

<b>Fluttwerk feature</b>	<b>Option (1-15)</b>
Duration of Fluttwerk	
Direction the abdomen points in	
Which wings are fluttered	

As all proper ethologists do, you have a lingering desire to investigate the proper basis of the Fluttwerk with Tinbergen’s four questions. You have already found out the function (purpose) of and causation (stimulus) leading to the Fluttwerk, and sadly are inadequately equipped to examine the evolution of the behaviour over the 38,000 years since the chain of Pillars was erected. That leaves you with the fourth question, that of ontology - **how did the Fluttwerk develop within a North Frontier Flutter’s lifespan?**

Conveniently, you find a young Flutter from the North Frontier who has sadly been separated from its group. You sneakily put a convincing model of a spice harvester near it and watch it from the distance. The poor thing gets close to the model and eats it up in one gulp. It gets scratched on the head by the metal though, and it makes this weird star-shaped scar. What’s more interesting than that is that it surprisingly does not perform the Fluttwerk. A few days later, it reunites with the group (woohoo)! You don’t see how you can further your research on the behaviour’s ontology, so you wrap this funky study up and head back to rest for the evening.

\*\*\*

Time passes. It's been a few decades since you came to Arrakis. Now, it's time for you to pack up and return to your home planet for retirement. You decide to say goodbye to the Flutters that defined your career on this desert planet in a symbolic way to celebrate your success. The decoding of the Fluttwerk got you the Gesserit Medal from the Sisterhood of Science, after all. On your way there, you see a Flutter (as big as they get) with a star-shaped scar... and then you see it once more.

In 10221 AG, the last-ever Fluttwerk you will get to study.

You are suddenly consumed by your thoughts over the work you did with the Flutters over the past few decades, but there is little time to mull. You need to pack for the Spacing Guild ship. You run back to your shelter, emotions running high and your mind in a whirl. You suppose this is the end.

**Q7.** Reflecting on your work, indicate whether the following statements are true or false. **(40 points)**

*(Mark each statement as true or false.)*

- A. The North Frontier population underwent the founder effect.
- B. This two-species situation can be described as cladogenesis.
- C. The chain of Pillars can be thought of as the isolating mechanism.
- D. The Fluttwerk is a learned behaviour.

## P23: It's time for a face lift I

(150 points)

Theropoda is a dinosaur clade characterised by hollow bones and three toes and claws on each limb. They were terrestrial predators of the Late Triassic and became the dominant predators of the land during the Jurassic and Cretaceous. While all dinosaurs are currently extinct, we are still able to investigate their anatomy by making use of fossils.

Muscles work together with bones to produce movement. The function of muscles can be deduced based on their origin and extension. The origin of a muscle refers to the point where the muscle is fixed, while the insertion moves with each contraction. The origin of a muscle is usually attached to the more stable bone, while the insertion is attached to the more mobile bone. Thus, during contraction, the more mobile bone can be brought in closer proximity to the more stable bone.

Sean was on a trip to the Lee Kong Chian National History Museum (LKCNHM) when he spotted several fossils. He is first introduced to Specimen 1. He is shown a video on how the contraction of the jaw muscles of Specimen 1 affects the movement of its jaw. Figure 1 shows the jaw muscles labelled.

*Note: For this question participants were provided with a short video clip extracted from the 1min 2s mark to 1min 5s mark of the following video: <https://www.youtube.com/watch?v=tdezagMXE2w>. The video clip was used with permission.*

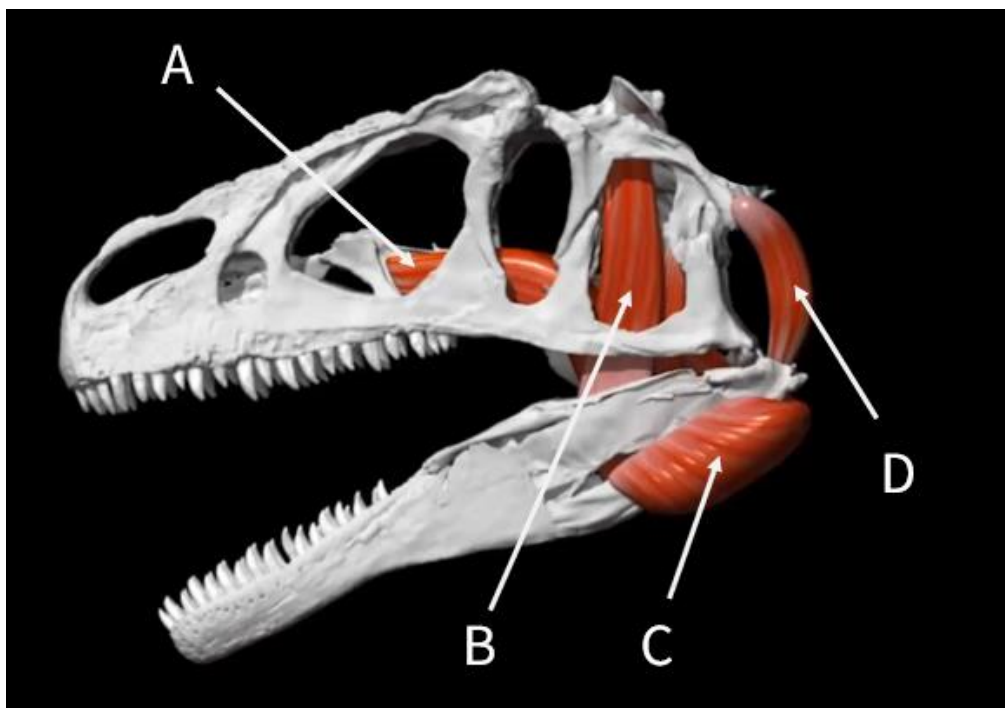

Figure 1: Jaw muscles

**Q1.** By referring to Figure 1 and the video, help Sean to match the function of the muscle on the jaw to each muscle. Enter *Open* if the muscle opens the jaw and *Close* if the muscle closes the jaw. **(40 points)**

(Enter either “Open” or “Close” to each row.)

Muscle	Function (“Open” or “Close”)
A	
B	
C	
D	

The lever action of a musculoskeletal system can be quantified by considering the moment of a force, or torque ( $\tau$ ). The torque can be calculated by the product of the force applied and the perpendicular distance between the point of the applied force and the pivot (Figure 2).

$$\tau = Fd$$

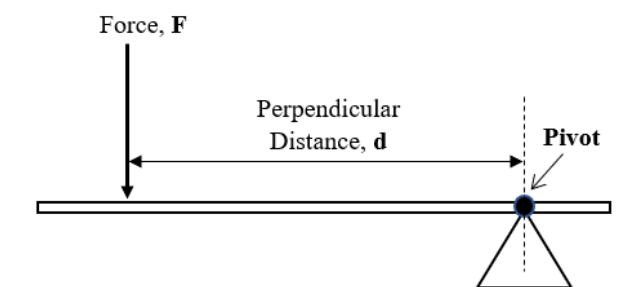

Figure 2: Moment of a force

According to the principles of moments, for a body to remain in rotational equilibrium, the sum of clockwise moments must equal the sum of counterclockwise moments.

Figure 3 shows the lever principle being applied to the human arm. The lever principle governing the mechanics of the human arm also applies to that of the arm of theropods.

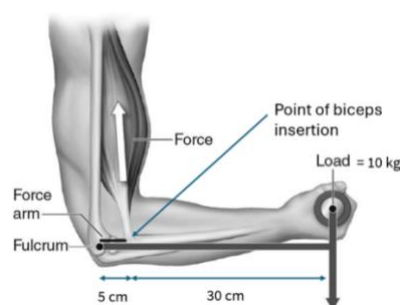

Figure 3: Mechanics of human arm



**Q2.** Calculate the value of the force exerted by the biceps muscle (in Newtons) in Figure 3 for the system to be in rotational equilibrium. Take gravitational acceleration to be  $10 \text{ m s}^{-2}$ . **(20 points)**  
*(Enter your answer correct to nearest whole number. Do not include any units.)*

**Q3.** If a theropod's bicep insertion was 7 cm from the elbow joint and the centre of the hand was 42 cm away from the point of insertion of the biceps, how fast would the object move (in  $\text{cm s}^{-1}$ ) when the biceps shorten  $3 \text{ cm s}^{-1}$ ? **(20 points)**  
*(Enter your answer correct to nearest whole number. Do not include any units.)*

Figure 4 shows several other fossil specimens that Sean saw at the LKCNHM exhibits.

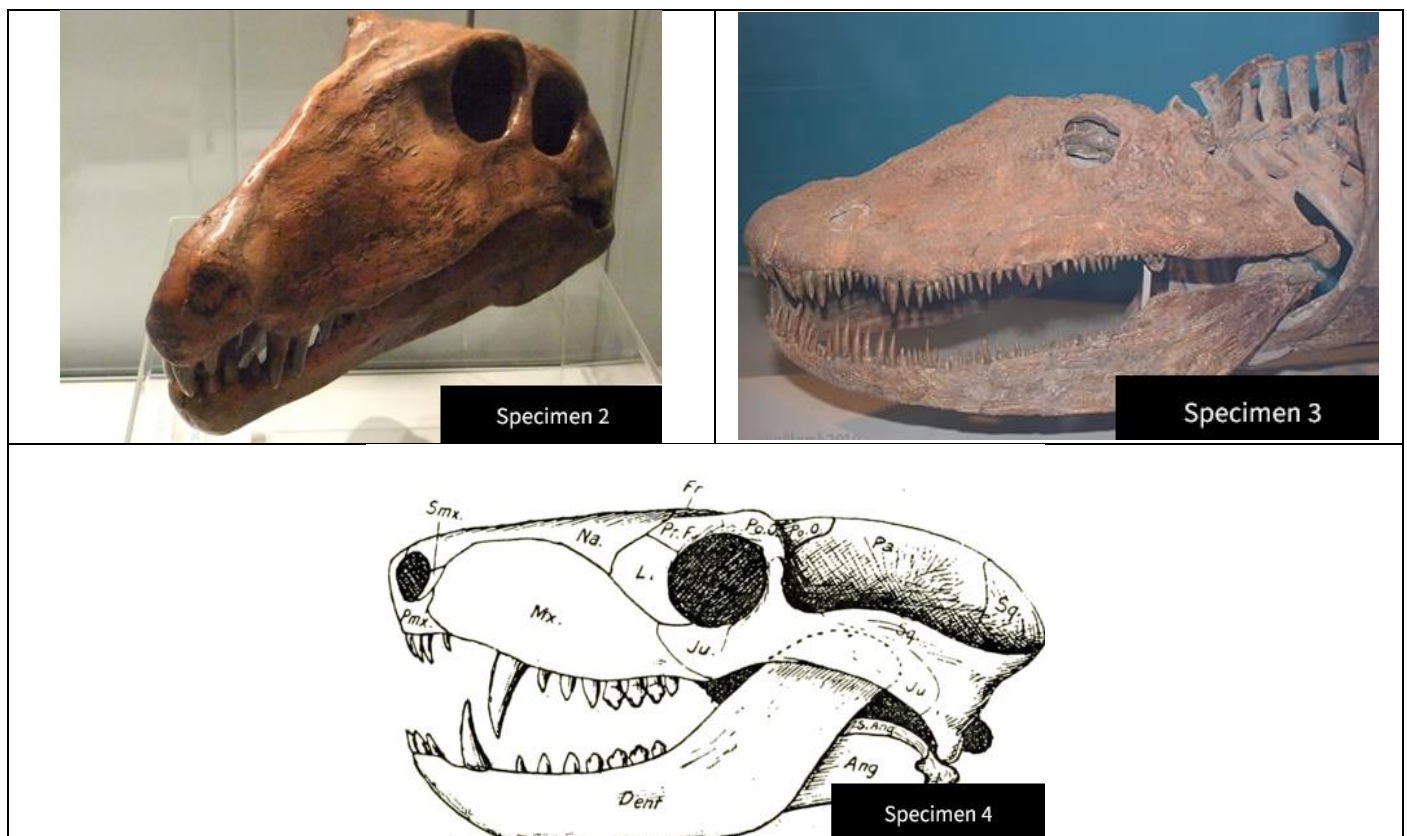

Figure 4: Specimens 2-4

Amniota is a clade of tetrapod vertebrates which includes dinosaurs, birds, and mammals. Amniotes show four different skull types: anapsid, diapsid, synapsid, as well as euryapsid. The skull types are distinguished by the presence and relative location of the temporal fenestrae.

**Q4.** Based on Figure 4 and the above information, indicate whether the following statements are true or false. **(40 points)**  
*(Mark each statement as true or false.)*

- A. Specimen 1 has three temporal fenestrae.
- B. Specimen 2 is a diapsid.
- C. Specimen 3 is more likely to be carnivorous than herbivorous.
- D. Specimen 3 is heterodontic.



The dental formula is a summary of the arrangement of teeth in an animal. The number of teeth of each type is written as a dental formula for one side of the mouth, or quadrant, with the upper and lower teeth shown on separate rows separated by a slash symbol (/). In each set, the order of teeth is from the outer anterior to inner posterior (Incisor, Canine, Premolar, Molar). The dental formula of adult humans is 2123/2123.

**Q5.** Indicate the dental formula of the upper and the lower teeth of Specimen 4 and the total number of teeth in the animal. Do not include the slash symbol (/). **(30 points)**

*(Enter a number to each row.)*

<b>Teeth</b>	<b>Answer</b>
Upper teeth	
Lower teeth	
Total Number of Teeth	

# P24: The Dancing Queen

(140 points)

In unfavourable environmental conditions, bacteria such as *B. subtilis* upregulate the expression of survival genes (e.g. those for formation of endospores). These genes are under negative control by the repressor protein AbrB, which prevents their unnecessary expression. One protein that contributes to the upregulation of survival genes is AbbA, which binds to and blocks AbrB from binding to DNA.

DNA stands for deoxyribonucleic acid, which is made of a phosphate backbone, deoxyribose sugar, and nitrogenous base. The structure of DNA is seen below.

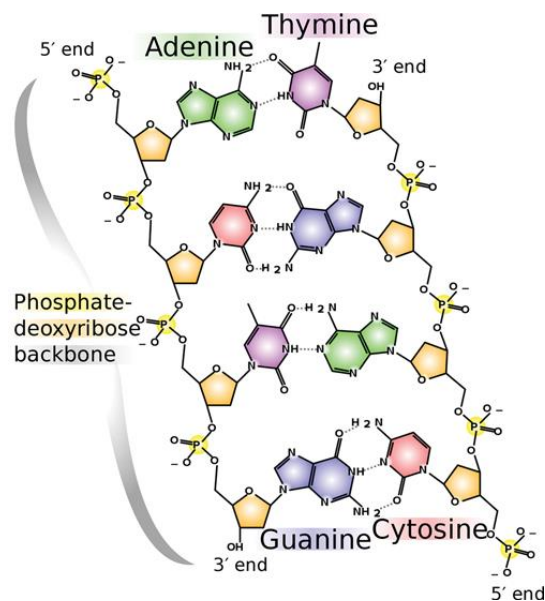

Figure 1: DNA structure

**Q1:** AbbA forms a dimer and mimics the structure of DNA. Considering the structure of the DNA backbone in Figure 1, which of the following amino acids are likely found in the AbrB-binding region of AbbA? (20 points)

(Select all correct options.)

- A. Alanine (A)
- B. Arginine (R)
- C. Aspartic Acid (D)
- D. Cysteine (C)
- E. Glutamic Acid (E)
- F. Isoleucine (I)
- G. Lysine (K)
- H. Tryptophan (W)

The dimerised nature of AbbA was confirmed via Size-Exclusion Chromatography (SEC) and Matrix-Assisted Laser Desorption/Ionisation Time-of-Flight (MALDI-TOF) Mass Spectrometry. SEC involves passing the solution through a column containing gel beads with small pores. Small molecules pass through the pores and are slowed down while larger molecules bypass the beads and travel straight through the column. In MALDI-TOF, molecules are ionised and travel down a path of fixed length. The ionised molecules are separated by their mass-to-charge ( $m/z$ ) ratio, with higher  $m/z$  ratio travelling slower within the electric field than lighter molecules with lower  $m/z$  ratio. Most molecules pick up a singular positive charge from the ionisation process.

**Q2.** Indicate whether the following statements regarding these two forms of mass spectrometry are true or false. **(40 points)**

*(Mark each statement as true or false.)*

- A. In SEC, an AbbA dimer would pass through the column faster and be eluted earlier than an AbbA monomer.
- B. Bio-gel P-60 is appropriate for isolating AbbA and IgG antibodies from a mixture of proteins via SEC.
- C. In TOF mass spectrometry, an AbbA dimer would pass through the spectrometer faster and be detected earlier than an AbbA monomer (assuming equal charge).
- D. A strong base is required for MALDI-TOF to produce ions containing the sample for analysis.

In SDS-PAGE (Sodium Dodecyl Sulphate Polyacrylamide Gel Electrophoresis), proteins are denatured by the SDS buffer and separated by molecular weight through electrophoresis, so proteins with equal molecular weight (and likely identity) would be found in the same horizontal band of the gel. This technique has been used to investigate AbrB.

Literature shows that four arginine residues (R8, R15, R23, R24) are strongly conserved in AbrB and are critical for its ability to bind DNA. To investigate whether the same residues are necessary for AbrB to bind to AbbA, researchers purified wild-type His<sub>6</sub>-AbrB, His<sub>6</sub>-AbrB<sup>R8A</sup>, His<sub>6</sub>-AbrB<sup>R15A</sup>, His<sub>6</sub>-AbrB<sup>R23A</sup>, and His<sub>6</sub>-AbrB<sup>R24A</sup> from bacterial cell lysate. (Note: His<sub>6</sub>-AbrB<sup>R8A</sup> indicates that AbrB has a 6x histidine tag and that R8 is mutant and nonfunctional in this protein.) Chromatography was conducted and the load (L), flow-through (FT), wash (W) and eluate (E) were run through SDS-PAGE and stained with Coomassie Blue.

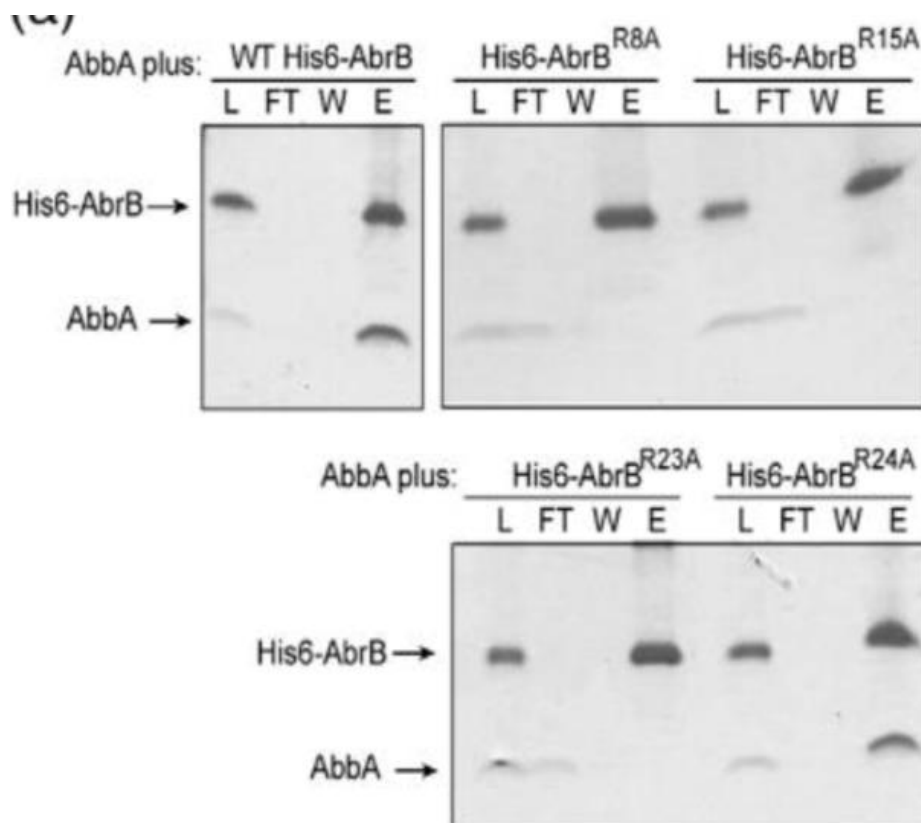

Figure 2: SDS-PAGE gel from chromatography. Coomassie Blue stains proteins.

**Q3.** What type of chromatography was likely used to purify the His6-AbrB:AbbA complexes? **(20 points)**

*(Select the correct option.)*

- A. Size Exclusion Chromatography
- B. Cation Exchange Chromatography
- C. Anion Exchange Chromatography
- D. Affinity Chromatography
- E. High-pressure Liquid Chromatography
- F. Thin Layer Chromatography
- G. Cannot be deduced

**Q4.** Which of the arginine residues are necessary for AbbA to bind to AbrB? **(20 points)**

*(Select all correct options.)*

- A. R8
- B. R15
- C. R23
- D. R24

**Q5.** Indicate whether the following statements regarding the experiment above are true or false.

**(40 points)**

*(Mark each statement as true or false.)*

- A. There are traces of AbbA detected in the load solution because some AbbA is still able to bind to AbrB with mutant arginine residues.
- B. An imidazole buffer should be used for the wash step because it competes with the His-tagged proteins and prevents unwanted proteins from binding to the column.
- C. AbbA is a competitive inhibitor of AbrB.
- D. 2D electrophoresis could have been used to produce Figure 2.

# P25: Potato Disease

(180 points)

The Potato Disease (PDT) is a rare but completely-penetrant disease found in individuals in the country of BioMania. PDT is caused by a single transversion mutation in the 5200bp-long gene *potate*. This mutation causes the face to turn yellow and the brain to swell up. This causes encephalitis and meningitis, which quickly results in death within two years that symptoms manifest.

PDT is usually diagnosed by genetic testing of a microsatellite region situated sufficiently close to the gene that it is effectively completely linked. Figure 1 shows the normal and mutant alleles and their respectively linked microsatellite.

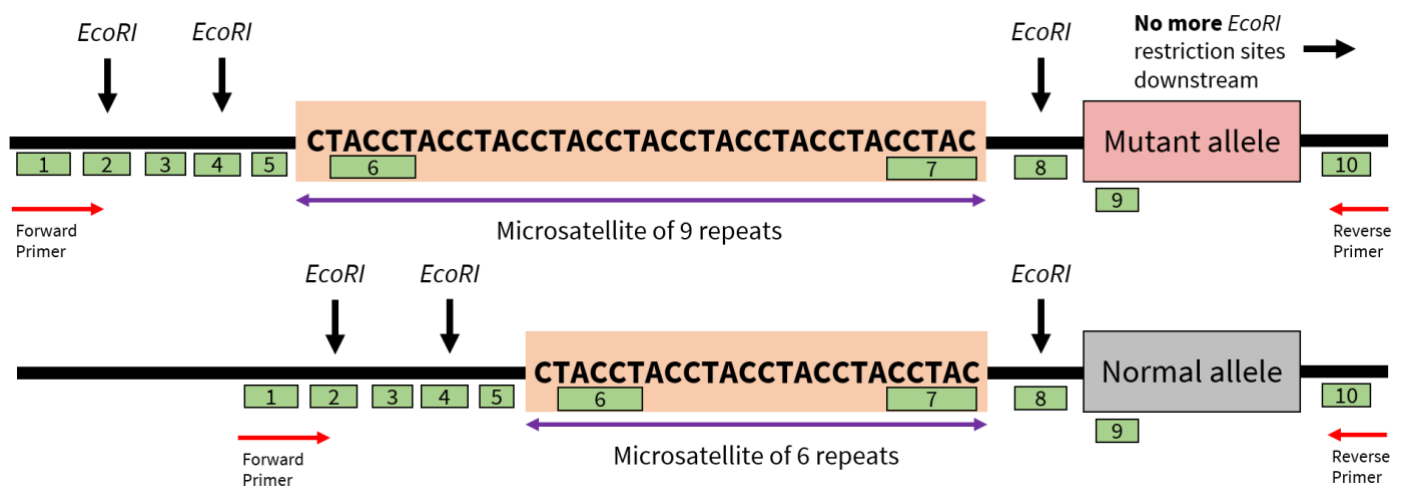

Figure 1: Map of *potate* gene and its linked microsatellite. *EcoRI* restriction sites are indicated. No *EcoRI* restriction sites can be found in all the 2 million base pairs downstream of the *potate* gene. Green boxes indicate possible radioactive probes.

These microsatellite regions are situated between two *EcoRI* restriction sites as seen in Figure 1. To perform the protocol, Jason first performed PCR using primers as indicated in red in Figure 1. He then cleaved the DNA fragment using *EcoRI*, removed the *EcoRI* enzymes, and then incubated the DNA fragments with radioactive probes to produce the result in Figure 2. He did so for Generations I and II but did not do so for Individual III-1 as the child was too young. However, as Joseph was a potato, he forgot to label the lanes and had no clue which lane corresponded to which individual (*bruh*).

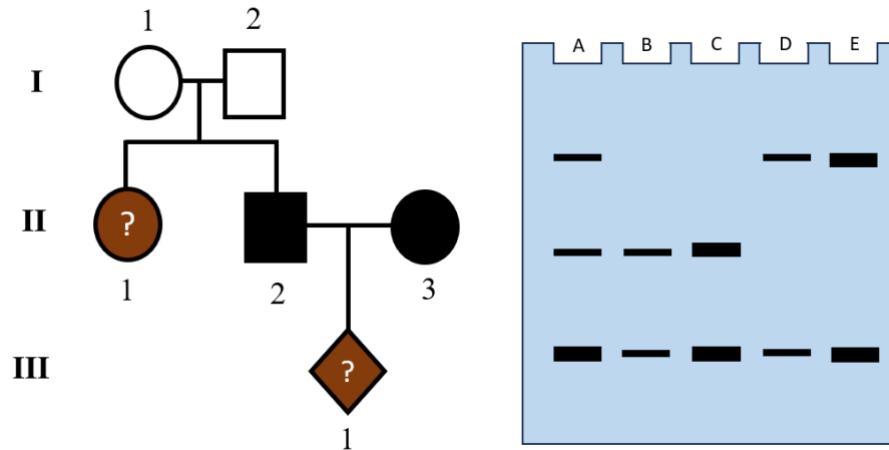

Figure 2: (left) Pedigree of a family with PDT. White indicates that the individual does not have PDT while black indicates that the individual is affected. However, it is unknown whether Individuals II-1 and III-1 are affected. (right) Gel electrophoresis of the samples of Generations I and II after incubation with radioactive probes

**Q1.** You used only one type of probe to conduct the experiment. Which probes, when used individually, could have been used to produce the result in Figure 2? **(30 points)**

(Select all correct options.)

- A. Probe 1
- B. Probe 2
- C. Probe 3
- D. Probe 4
- E. Probe 5
- F. Probe 6
- G. Probe 7
- H. Probe 8
- I. Probe 9
- J. Probe 10

**Q2.** What is the nucleotide sequence of the microsatellite repeat? **(10 points)**

(Enter a string of letters. Do not include 5' or 3'.)



**Q3.** What is the mode of inheritance of PDT? **(20 points)**

*(Select the correct option.)*

- A. Autosomal recessive
- B. Autosomal dominant
- C. X-linked recessive
- D. X-linked dominant
- E. Y-linked
- F. Paternal imprinting
- G. Maternal imprinting
- H. Cytoplasmic inheritance

**Q4.** Indicate whether the following statements are true or false. **(50 points)**

*(Mark each statement as true or false.)*

- A. The mutation could have been a change from cytosine to thymine.
- B. The mutant allele is a lethal allele.
- C. Individual II-1 is unaffected but is a carrier.
- D. Lane B corresponds to Individual II-3.
- E. PDT is unlikely to develop symptoms below 10 years of age.

**Q5.** What is the probability that Individual III-1 will develop PDT? **(10 points)**

*(Enter your answer as a decimal correct to 3 s.f.)*

**Q6.** Individuals I-1 and I-2 decide to have ten more children in addition to the two they already have. What is the probability that exactly four of the ten children subsequently develop PDT? **(30 points)**

*(Enter your answer as a decimal correct to 3 s.f.)*

A similar disease, *patata*, is inherited in an autosomal dominant manner. A variable number tandem repeat (VNTR) is found near to the gene locus that causes *patata*.

Figure 3 shows a pedigree with affected individuals shaded black and their respective VNTRs indicated. There are seven different VNTRs (V1 to V7).

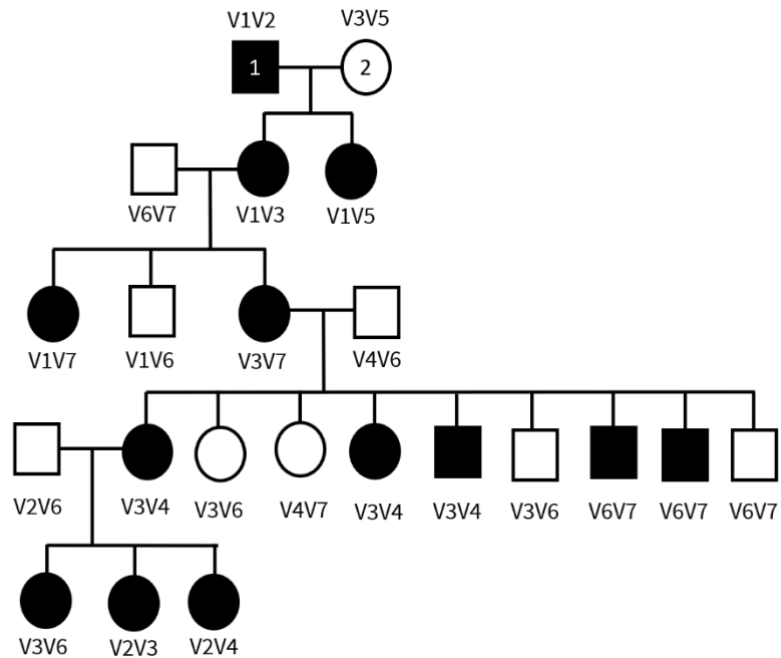

Figure 3: Pedigree of *patata* in a family. Affected individuals are shaded black. The respective VNTRs are indicated. Individuals 1 and 2 are known to be homozygous.

**Q7.** Based on Figure 3, calculate the map distance between the VNTR locus and the *patata* gene locus in map units (m.u.). **(30 points)**  
 (Enter your answer correct to 3 s.f. Do not enter any units.)

# P26: Abs

(130 points)

Abscisic acid (ABA) is known to regulate dormancy of seeds and to regulate other stress responses in plants. Phytochromes are light photoreceptors that are involved in photoperception of the light environment. Faith hypothesises that phytochromes regulate the signalling of ABA in plants. She decides to investigate how phytochrome A (*phyA*) and phytochrome B (*phyB*) regulate ABA signalling in *Arabidopsis*.

Faith sowed wild-type (WT), *phyA* mutant (*phyA*<sup>-</sup>), and *phyB* mutant (*phyB*<sup>-</sup>) seeds on medium containing various concentrations of ABA and grew them vertically in R light for 5 days. The results are seen in Figure 1A. Then, she sowed the seeds of WT, *phyA* mutant, and two *phyA* complementation lines on medium containing various concentrations of ABA for 1 day in white light, and then transferred to FR light and incubated for additional 6 days. The results are seen in Figure 1B.

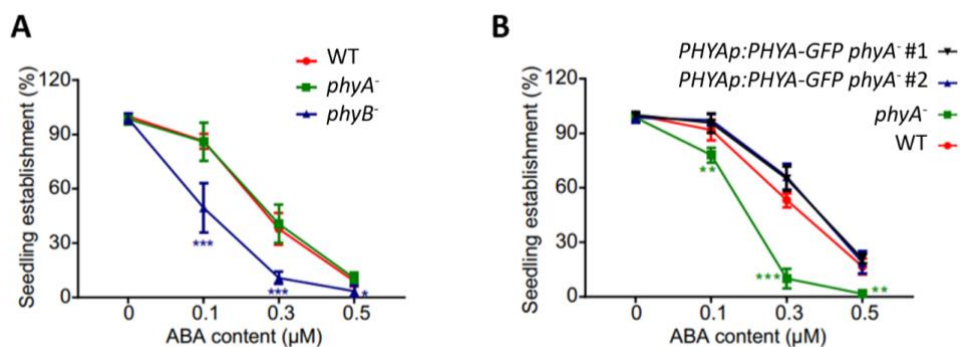

Figure 1: ABA on *phyA*<sup>-</sup> and *phyB*<sup>-</sup> mutants' germination.

(A) Seedling establishment rates of WT, *phyA*<sup>-</sup>, and *phyB*<sup>-</sup> seedlings grown on medium containing different concentrations of ABA in R light for 5 days.

(B) Seedling establishment rates of WT, *phyA*<sup>-</sup>, and two *phyA*<sup>-</sup> complementation lines grown vertically on the medium containing the indicated concentrations of ABA in white light for 1 day, then transferred to FR light, and incubated for an additional of 6 days. Complementation lines contained *phyA*-GFP under the control of the native PHYA promoter.

**Q1.** Indicate whether the following statements are true or false. (40 points)

(Mark each statement as true or false.)

- phyA* has negligible effect on the regulation of ABA signalling in R light but *phyB* positively regulates ABA signalling in R light.
- phyA* may be epistatic to *phyB*.
- phyA* mutant seeds show low germination rates under FR light in the presence of ABA.
- phyA* mutant seeds become more sensitive to ABA if *phyA*-GFP is introduced under the control of a native PHYA promoter.

To further investigate the effects of phyA and phyB on ABA signalling, Faith created an ABA system in yeast cells that emulates the ABA-signalling pathway, with a downstream transcription factor that controls a reporter. She then fused a nuclear localisation signal (NLS) with phyA, phyB or COP1 (phyA-NLS, phyB-NLS, NLS-COP1 respectively) and they were expressed in these yeast cells. PCB was added as the substrate for phytochromes. In the presence of R or FR light, the phyA and phyB proteins can thus convert into their Pr or Pfr forms. The results are shown in Figure 2A-C.

In addition, she also tested the effect of a phyA point mutation phyA #3. The results are shown in Figure 2D. Figure 2E shows the results when one of the components of the emulated ABA-signalling pathway, KT8, is substituted with homologous KE7 and KB9 respectively. Figure 2F shows the results when ABI1 in the pathway is replaced with homologous ABI2.

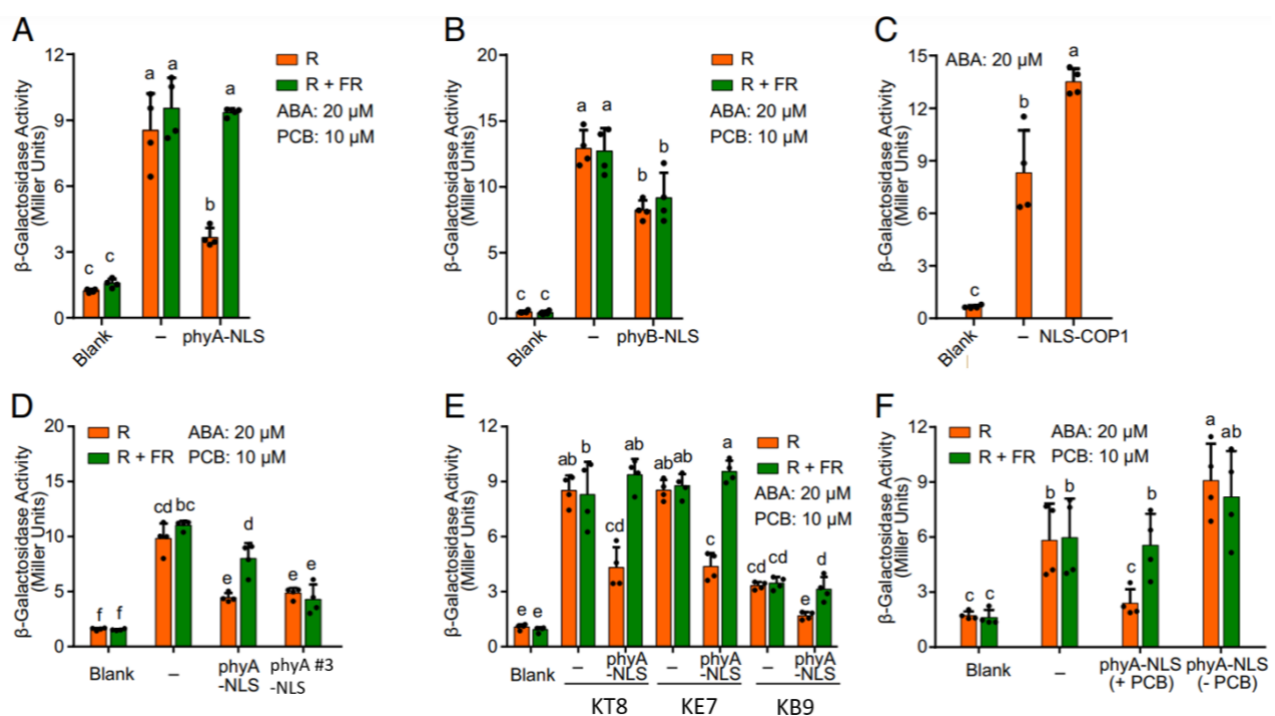

Figure 2: phyA, phyB, and COP1 effects on ABA signalling in yeast cells.  
**(A-C)** phyA (A), phyB (B), and COP1 (C) effect on ABA signalling.  
**(D)** phyA and mutant phyA #3 on ABA signalling  
**(E)** Effects on ABA signalling after substitution of KT8 with KE7 or KB9.  
**(F)** Effects on ABA signalling after substitution of ABI1 with ABI2 and in the presence or absence of PCB.

**Q2.** Indicate the effect of the following proteins on the regulation of ABA signalling in the transformed yeast cells by matching the following options (1-3) to the correct row. **(50 points)**  
*(Match the correct number to the correct row.)*

1. Positive
2. Negative
3. Negligible

<b>Protein</b>	<b>Effect (1-3)</b>
Pr form of phyA	
Pfr form of phyA	
Pr form of phyB	
Pfr form of phyB	
COP1	

**Q3.** Indicate whether the following statements are true or false. **(40 points)**  
*(Mark each statement as true or false.)*

- A. phyA #3 likely contains a mutation that inhibits the conversion of Pfr to Pr.
- B. phyA affects the ABA signalling pathway when KT8 is substituted with KB9 but not when KT8 is substituted with KE7.
- C. phyA still inhibits the ABA signalling pathway even after ABI1 is substituted with ABI2.
- D. The predominant effect of phyA on ABA signalling is via the Pfr form.

# P27: It's time for a face lift II

(150 points)

Sean continues his trip in the Lee Kong Chian National History Museum (LKCNHM). He sees Figure 1, which shows the evolution of cynodonts and mammaliaforms as well as their dietary adaptations and modifications in skull morphology. He also sees Figure 2, the skull of *Pascualgnathus*.

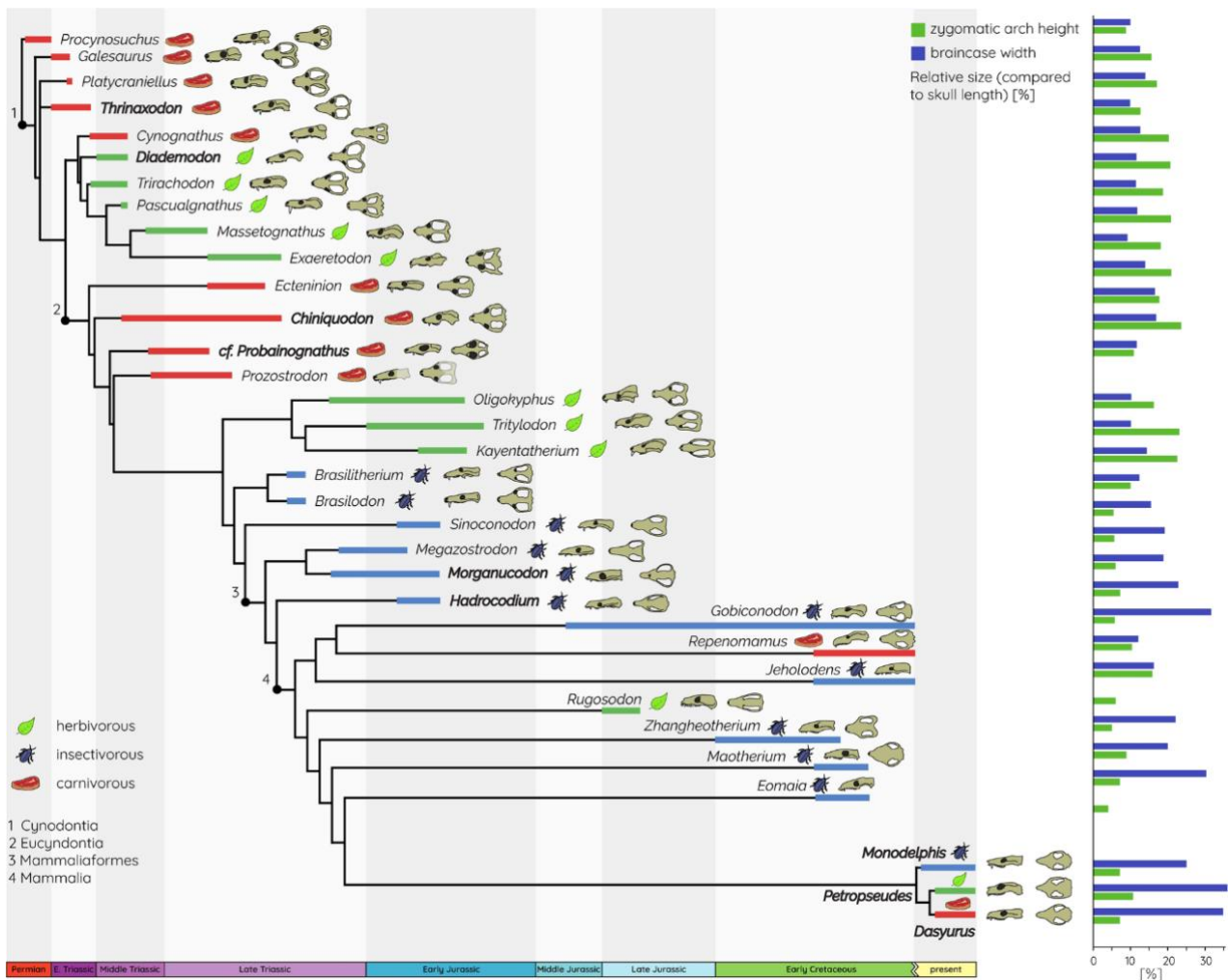

Figure 1: Evolutionary of cynodonts and mammaliaforms.

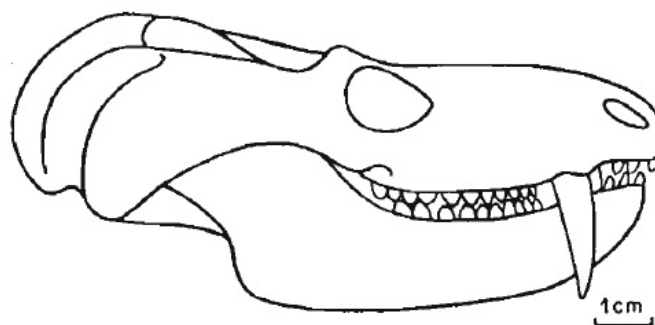

Figure 2: *Pascualgnathus* skull

**Q1.** By referring to Figure 1, indicate whether the following statements are true or false. **(40 points)**

(Mark each statement as true or false.)

- A. The changes in the relative sizes on the right-hand side of Figure 1 could have been driven by a selective advantage in stronger skulls.
- B. Most cynodonts have a zygomatic arch length of 5% to 15% of the skull length.
- C. *Eomaia* and *Maothorium* are sister taxa.
- D. Herbivory is an autapomorphic trait in *Rugosodon*.

**Q2.** By referring to Figure 1, indicate whether the following statements are true or false. **(40 points)**

(Mark each statement as true or false.)

- A. The Mammalia clade likely underwent adaptive radiation.
- B. The extinct species in Figure 1 form a monophyletic clade.
- C. The dental arrangement of *Pascualgnathus* is unusual considering its diet.
- D. The most recent common ancestor of *Rugosodon* and *Brasilitherium* is more recent than the most recent common ancestor of *Zhanghoetherium* and *Brasilodon*.

Occam's razor is a principle used in phylogenetics to find the most parsimonious phylogenetic tree. Occam's razor states that if hypotheses have equal explanatory powers, the one requiring the fewest assumptions should be the preferred hypothesis. Hence, with all other things being equal, the phylogenetic tree which requires the fewest number of evolutionary changes is the best hypothesis and can be used as the most parsimonious tree.

**Q3.** Using Occam's razor, calculate the most likely number of diet changes that occurred in the phylogenetic tree in Figure 1. **(10 points)**

(Enter a whole number.)

Fossils are also useful in helping to determine the relative ages of different strata. They are called index fossils. Figure 3 shows several outcrops taken from different parts of the world containing different fossils.

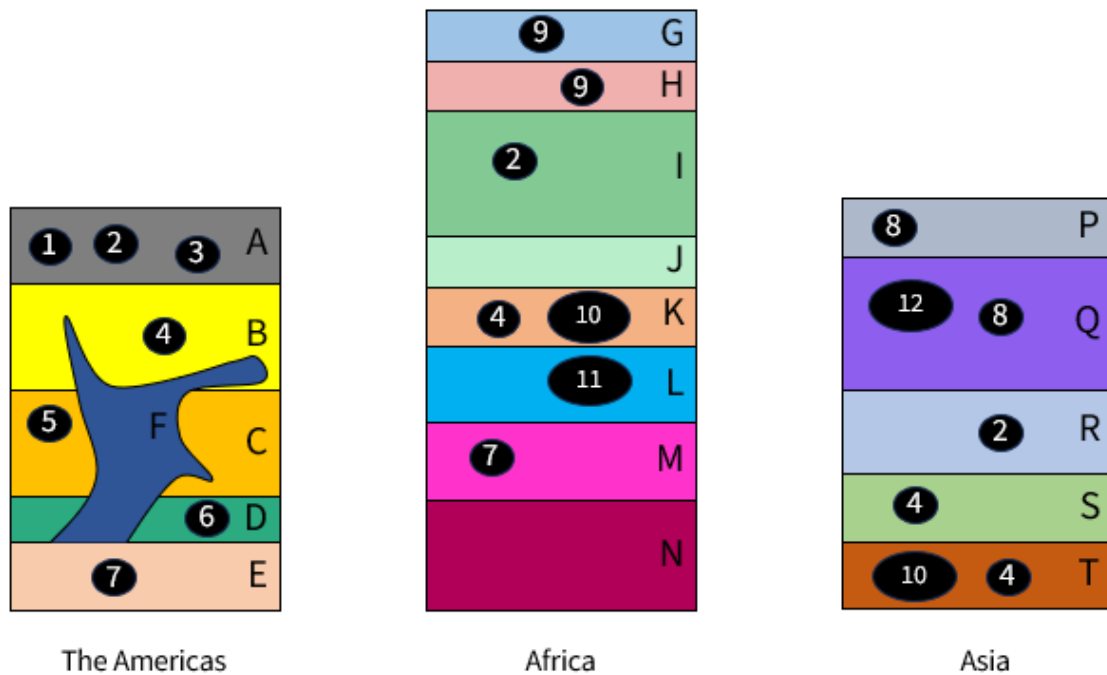

Figure 3: Outcrops. Fossils are in numbers (1-12) and rock layers are in letters (A-T). To avoid confusion no layer is labelled O.

**Q4.** Indicate which fossil (1-12) should be used as the index fossil. **(10 points)**

*(Enter a whole number.)*

**Q5.** Indicate whether the following statements are true or false. **(50 points)**

*(Mark each statement as true or false.)*

- A. Since Asia has a fewer number of strata as compared to Africa, we can deduce that Africa existed before Asia.
- B. Fossil 3 is older than Fossil 9.
- C. Layer F is older than Layer B.
- D. Layer J is younger than Layer S.
- E. Lava likely flowed onto the surface in Layer J but not Layer R.



# P28: X marks the spot

(130 points)

After much X-raying and crossbreeding, Dr Pahari has created a pure-breeding *Drosophila melanogaster* with genotype  $bbprprvvgss$ , where the gene loci of  $b$ ,  $pr$ ,  $vg$  and  $s$  are all found on the same chromosome. Excited, he crossed it with a wild-type strain with  $b^+b^+pr^+pr^+vg^+vg^+s^+s^+$  genotype and performed a test cross of the  $F_1$  generation. The + sign indicates the wild-type allele, while the lack of the + sign indicates the mutant recessive allele.

Legend	
$b^+$ : black body	$b$ : grey body
$pr^+$ : red eyes	$pr$ : purple eyes
$vg^+$ : normal wings	$vg$ : vestigial wings
$s^+$ : long bristles	$s$ : short bristles

The results are shown in the table below.

Phenotype	Number
Black body, red eyes, normal wings, long bristles	411
Black body, red eyes, normal wings, short bristles	409
Black body, red eyes, vestigial wings, long bristles	61
Black body, red eyes, vestigial wings, short bristles	58
Black body, purple eyes, normal wings, long bristles	2
Black body, purple eyes, normal wings, short bristles	2
Black body, purple eyes, vestigial wings, long bristles	30
Black body, purple eyes, vestigial wings, short bristles	28
Grey body, red eyes, normal wings, long bristles	28
Grey body, red eyes, normal wings, short bristles	29
Grey body, red eyes, vestigial wings, long bristles	1
Grey body, red eyes, vestigial wings, short bristles	3

Grey body, purple eyes, normal wings, long bristles	60
Grey body, purple eyes, normal wings, short bristles	61
Grey body, purple eyes, vestigial wings, long bristles	412
Grey body, purple eyes, vestigial wings, short bristles	407
<b>Total</b>	2002

The four genes on the chromosome are illustrated in Figure 1. While the diagram is not to scale and the genes are not labelled, you know that genes A and B are closer to each other than genes B and C are.

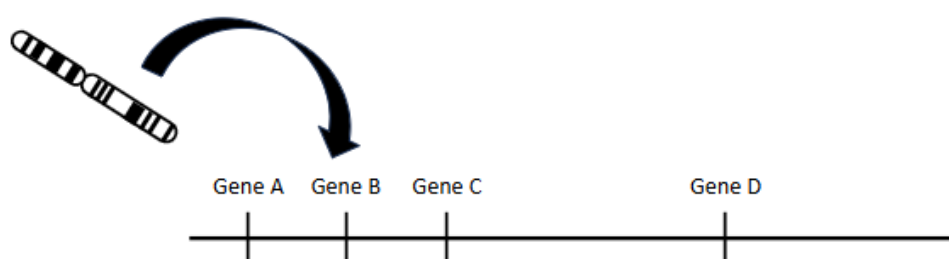

Figure 1: Diagram of genes on chromosome. Not to scale.

**Q1.** Gene D is so far apart from the other three gene loci that it is practically genetically unlinked. Which gene does gene D represent? **(10 points)**

*(Select the correct option.)*

- A.  $b^+/b$
- B.  $pr^+/pr$
- C.  $vg^+/vg$
- D.  $s^+/s$

**Q2.** The other 3 genes are genetically linked to each other. Which gene does gene B represent? **(10 points)**

*(Select the correct option.)*

- A.  $b^+/b$
- B.  $pr^+/pr$
- C.  $vg^+/vg$
- D.  $s^+/s$

**Q3.** Calculate the genetic distance between genes A and B in map units (m.u.). **(20 points)**

*(Enter your answer correct to 3 s.f. Do not enter any units.)*

**Q4.** Calculate the genetic distance between genes B and C in map units (m.u.). **(20 points)**

*(Enter your answer correct to 3 s.f. Do not enter any units.)*

For a general heterozygote with genotype  $AaBbCc$ , where the gene loci  $A/a$ ,  $B/b$  and  $C/c$  lie on the same chromosome in that order, two crossover events must occur to get a gamete with genotype  $aBc$  or  $AbC$ , which are known as double recombinants (Figure 2). Hypothetically, the expected frequency of double recombinants can be derived from multiplying the genetic distance between  $A/a$  and  $B/b$  and the genetic distance between  $B/b$  and  $C/c$ . However, in reality, the observed frequency of double recombinants is often lower due to a phenomenon known as crossover interference. The ratio of the observed frequency of double recombinants to the expected frequency is known as the coefficient of coincidence. The complement of the coefficient of coincidence is the degree of interference.

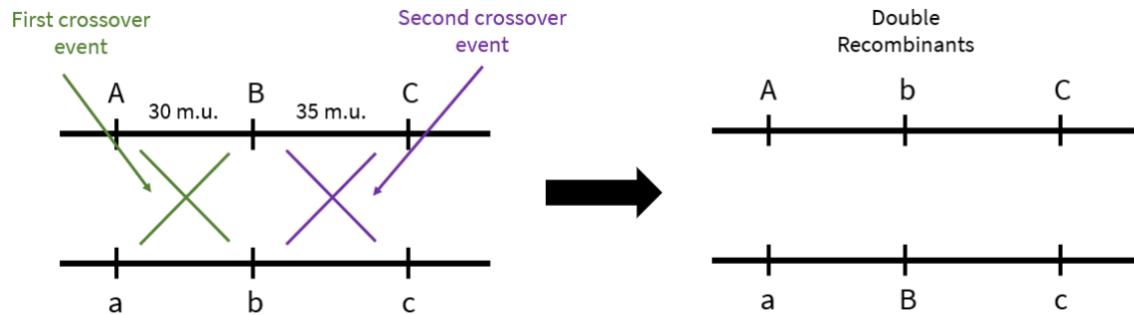

Figure 2: Double recombinants

**Q5.** Calculate the degree of interference observed. **(30 points)**

(Enter your answer correct to 3 s.f.)

**Q6.** Dr Pahari ran out of *Drosophila melanogaster* with genotype  $bbprprvgvgss$ . He decides to cross 2 *Drosophila melanogaster* heterozygotes from the  $F_1$  generation to create more *Drosophila melanogaster* with genotype  $bbprprvgvgss$ . What is the chance that an offspring fly has the desired genotype? **(40 points)**

(Enter your answer as a decimal correct to 3 s.f.)

# P29: Y2H? Y2K?

(190 points)

The Yeast-Two-Hybrid (Y2H) System is a molecular biology technique used to discover protein-protein interactions. Y2H also makes use of transcription factors and the yeast *Saccharomyces cerevisiae* (*S. cerevisiae*).

All transcription factors are made of two modular domains: a DNA-binding domain (BD) and an activation domain (AD) that recruits RNA polymerase to bind to it. Hence the transcription factor (TF) is necessary as RNA polymerase cannot bind to the promoter by itself, and a transcription factor that lacks either domain is non-functional.

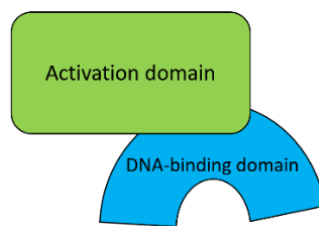

Figure 1: BD and AD of Transcription Factors

A reporter gene such as *lacZ* with a promoter is chosen. Using recombinant technology, the genes for the two proteins of interests, say X and Y, are fused to the genes coding for AD and BD of the transcription factor respectively. The AD and BD-coding genes are separated, often on different plasmids, so that the two domains are separate and non-functional by itself. The two proteins of interest, say X and Y, are fused to AD and BD respectively, forming two proteins AD-X (prey) and Y-BD (bait). If the two proteins interact, X and Y will bind with each other, forming an AD-X-Y-BD protein complex which brings AD and BD close to each other restoring the TF, thus the TF is now functional and transcription of the reporter gene will occur. Transcription for the reporter gene *lacZ* can be seen by the products of the gene. In this case, *lacZ* produces  $\beta$ -galactosidase which hydrolyses X-gal to form a blue product. Conversely, no product will be formed if the two proteins do not interact as the TF cannot be restored.

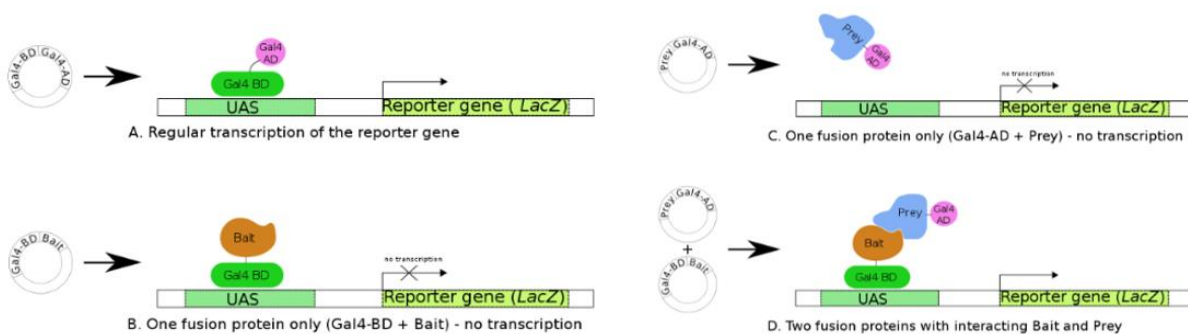

Figure 2: Bait and Prey on Y2H

Faith is investigating the interactions among 5 proteins, P1, P2, P3, X, and Y. X is known to interact with Y. The figure below shows the growth and  $\beta$ -galactosidase activity of yeast cells expressing different combinations of BD and AD fusions. The reporter gene codes for enzymes that synthesise leucine as well as  $\beta$ -galactosidase. The combinations of the plasmids are shown in Figure 3.

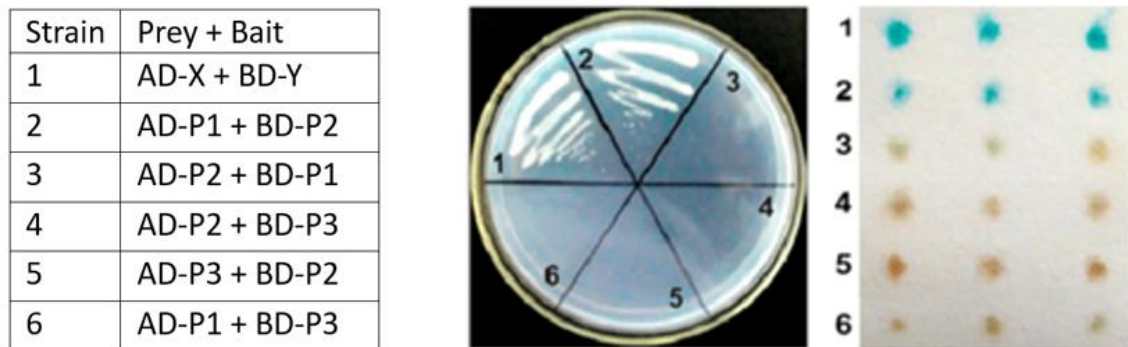

Figure 3: Y2H Assay Results on the five proteins. **Left panel:** Prey and Bait in yeast strains. **Middle panel:** Growth of yeast cells on a SD/-Leu dropout plate. **Right panel:** Activity of the  $\beta$ -gal of indicated strains.

**Q1.** Answer the following questions regarding the strains and the proteins. **(30 points)**

(Enter the correct answer to each row. Use None, 1, 2, 3, 4, 5, 6, or All to represent the strains, and P1, P2, or P3 to represent proteins.)

Question	Strain/Proteins
Positive control	
Negative control	
Which are the two proteins that bind together? Leave your answer as "P1P2" or "P2P3" or "P1P3".	

**Q2.** Indicate whether the following statements regarding modifications to the Y2H assay are true or false. "Work" implies that the assay is accurate and valid and the data can be used, but not necessarily yielding a positive result. **(40 points)**

(Mark each statement as true or false.)

- Y2H can still work even if the proteins are not folded in their specific conformation as long as the amino acid sequence where they interact is present.
- Y2H can still work between a soluble protein and an insoluble protein like myosin.
- Y2H can still work even if the two fusion proteins can independently activate the reporter gene.
- The Y2H system established in Figure 3 will still work even if the  $\beta$ -galactosidase enzyme coded for is non-functional.

**Q3.** Indicate whether the following statements regarding the Y2H assay are true or false. **(40 points)**

*(Mark each statement as true or false.)*

- A. A Y2H assay with RNA polymerase as bait and another protein as prey yields a blue solution. This means that RNA polymerase and the protein definitely interact in human cells.
- B. As the strain of yeast used cannot carry out oxidation between cysteine residues, a Y2H assay involving insulin and RTK will yield a negative result.
- C. Adding a substance that increases the electrostatic attraction between the two proteins of interest can increase the specificity of Y2H.
- D. Y2H can be used to discover most of the substrates that enzymes bind to.

Faith is interested in investigating the interactions between seven proteins (A to G) in humans. She makes use of a Y2H assay to deduce the interactions between different proteins.

Figure 4 shows the results of Y2H with X-gal using the different proteins as bait and prey. Unfortunately, due to poor experimental techniques, some of Faith's results are invalid and appear as black on Figure 4. Fortunately, Faith knows the Protein E is the first precursor in this pathway.

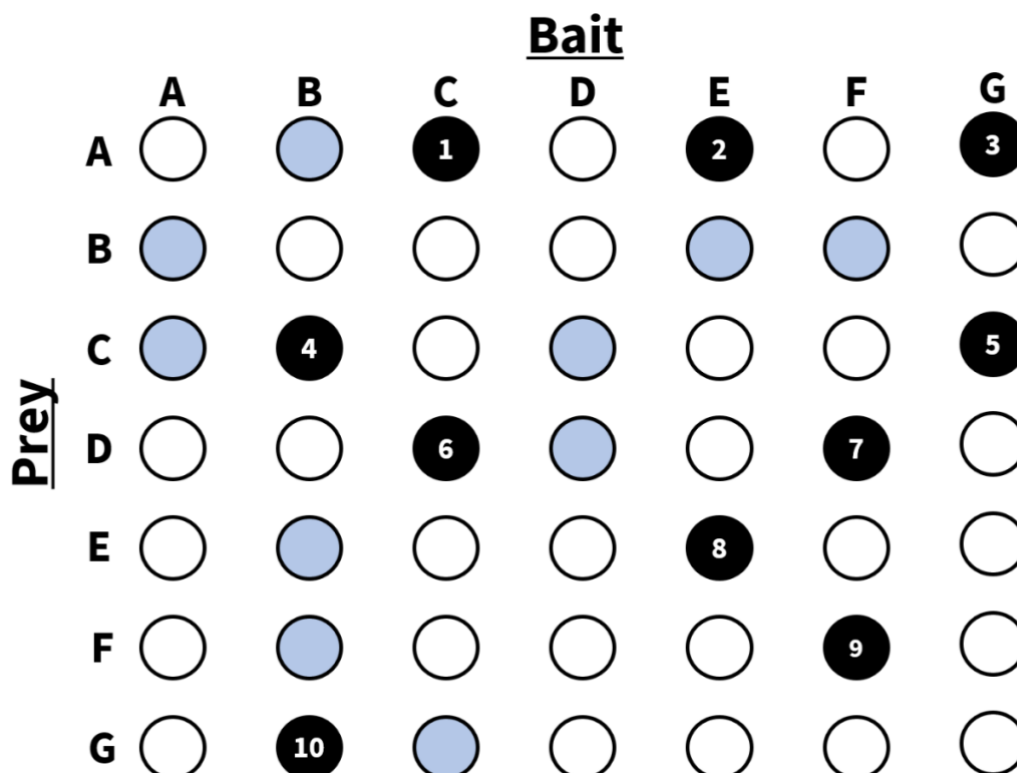

Figure 4: Results of Y2H using different proteins as bait and prey. Black dots represent failed Y2H assays due to poor experimental techniques.

The failed assays are numbered from 1 to 10.

**Q4.** Which protein(s) act downstream to protein A? **(10 points)**

*(Select all correct options.)*

- A. None
- B. Protein B
- C. Protein C
- D. Protein D
- E. Protein E
- F. Protein F
- G. Protein G

**Q5.** Based on Figure 4, which protein most likely exists as a homodimer? **(10 points)**

*(Select the correct option.)*

- A. Protein A
- B. Protein B
- C. Protein C
- D. Protein D
- E. Protein E
- F. Protein F
- G. Protein G

**Q6.** Based on Figure 4, indicate which of the failed assays would definitely have been positive (blue) if the assay had worked properly. **(10 points)**

*(Select all correct options.)*

- A. 1
- B. 2
- C. 3
- D. 4
- E. 5
- F. 6
- G. 7
- H. 8
- I. 9
- J. 10
- K. None



**Q7.** By deducing the interaction pathway between these seven proteins, indicate whether the following statements are true or false. **(50 points)**

*(Mark each statement as true or false.)*

- A. Protein A acts downstream of Protein B.
- B. Protein B acts downstream of Protein G.
- C. Protein D acts upstream of Protein G.
- D. Protein D acts downstream of Protein B.
- E. Protein F acts downstream of Protein D.



# P30: The Animal Kingdom

(220 points)

The Lee Kong Chian National History Museum (LKCNHM) is located in the Kent Ridge campus of the National University of Singapore and boasts over a million specimens from across Southeast Asia. On a learning journey to the LKCNHM, Kelly was very fascinated by the large biodiversity of specimens there. She asked the docent, “What’s the theme? There’s always a theme.” The docent replied, “I don’t tell you the theme, you see the theme,” and he promptly handed her an information booklet with a phylogenetic tree. The docent continued, “Here, each number in the dichotomous key corresponds to an animal specimen in the museum. See if you can identify them.”

<b><u>Dichotomous Key</u></b>	
<ol style="list-style-type: none"> <li>1. Radial symmetry               <ol style="list-style-type: none"> <li>1. Yes — go question 2</li> <li>2. No — go to question 3</li> </ol> </li> <li>2. Nematocysts               <ol style="list-style-type: none"> <li>1. Yes – Species 2</li> <li>2. No – Species 6</li> </ol> </li> <li>3. Vertebral Column               <ol style="list-style-type: none"> <li>1. Yes — go to question 5</li> <li>2. No — go to question 4</li> </ol> </li> <li>4. Sessile adult form               <ol style="list-style-type: none"> <li>1. Yes – Species 9</li> <li>2. No – Species 12</li> </ol> </li> <li>5. Bones               <ol style="list-style-type: none"> <li>1. Yes – go to question 7</li> <li>2. No – go to question 6</li> </ol> </li> <li>6. Jaw               <ol style="list-style-type: none"> <li>1. Yes – Species 1</li> <li>2. No – Species 3</li> </ol> </li> <li>7. Amniote               <ol style="list-style-type: none"> <li>1. Yes – go to question 10</li> <li>2. No – go to question 8</li> </ol> </li> <li>8. Positive breathing pressure               <ol style="list-style-type: none"> <li>1. Yes – Species 13</li> </ol> </li> </ol>	<ol style="list-style-type: none"> <li>2. No – go to question 9</li> <li>9. Lobed fin               <ol style="list-style-type: none"> <li>1. Yes – Species 10</li> <li>2. No – Species 4</li> </ol> </li> <li>10. Temporal opening on skull               <ol style="list-style-type: none"> <li>1. Yes – go to question 11</li> <li>2. No – Species 5</li> </ol> </li> <li>11. Egg laying               <ol style="list-style-type: none"> <li>1. Yes – go to question 13</li> <li>2. No – go to question 12</li> </ol> </li> <li>12. The species have transmissible Cancer               <ol style="list-style-type: none"> <li>1. Yes – Species 11</li> <li>2. No – Question 15</li> </ol> </li> <li>13. Eggshell hardness               <ol style="list-style-type: none"> <li>1. Soft – Question 14</li> <li>2. Hard – Species 15</li> </ol> </li> <li>14. Lactation               <ol style="list-style-type: none"> <li>1. Yes – Species 14</li> <li>2. No – Species 7</li> </ol> </li> <li>15. Presence of epipubic bones?               <ol style="list-style-type: none"> <li>1. Yes – Species 8</li> <li>2. No – Species 16</li> </ol> </li> </ol>

Figure 1: Kelly’s Dichotomous Key

Kelly's friend, Ryan, looked really interested in her dichotomous key. Hence, the docent also passed him an information booklet, but this booklet instead contained two phylogenetic trees. The docent pointed out a board in the far distance, saying, "Look at that board. Those 16 animal specimens are each represented by a number on Kelly's dichotomous key and a letter on Ryan's phylogenetic trees. But some of the animal specimens are already filled in in the phylogenetic trees for you!"

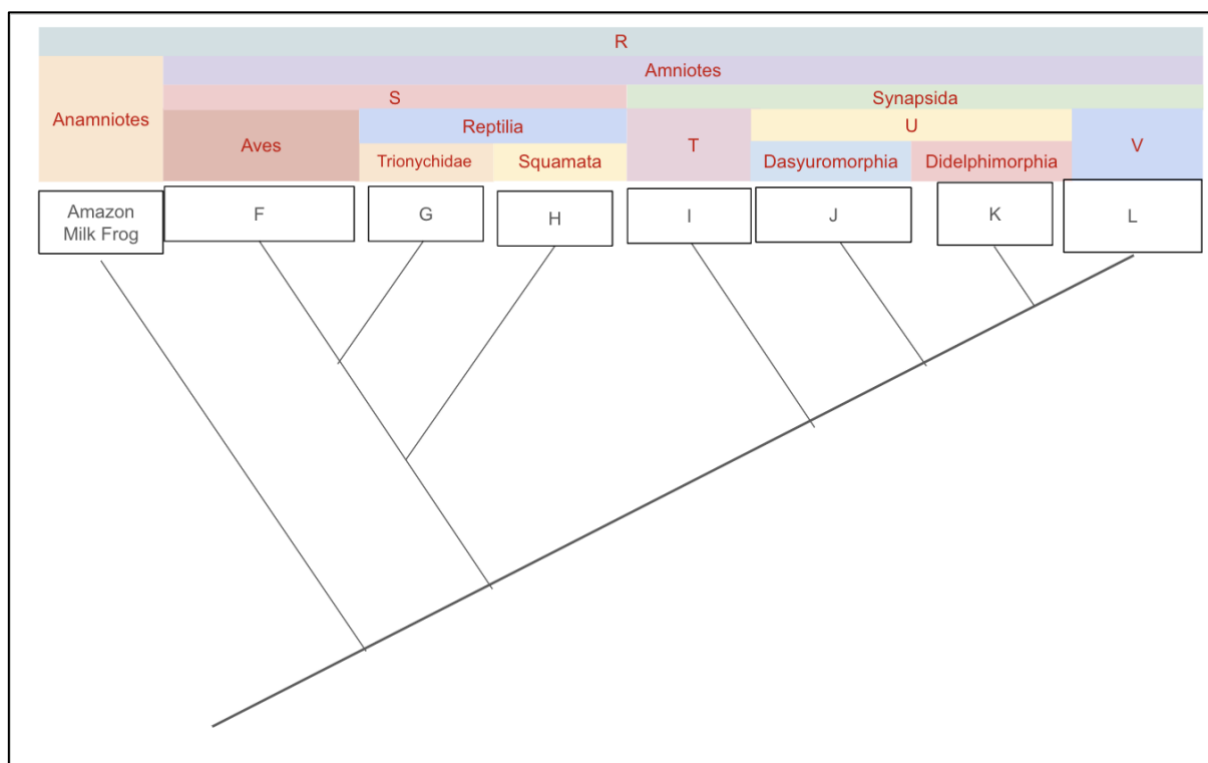
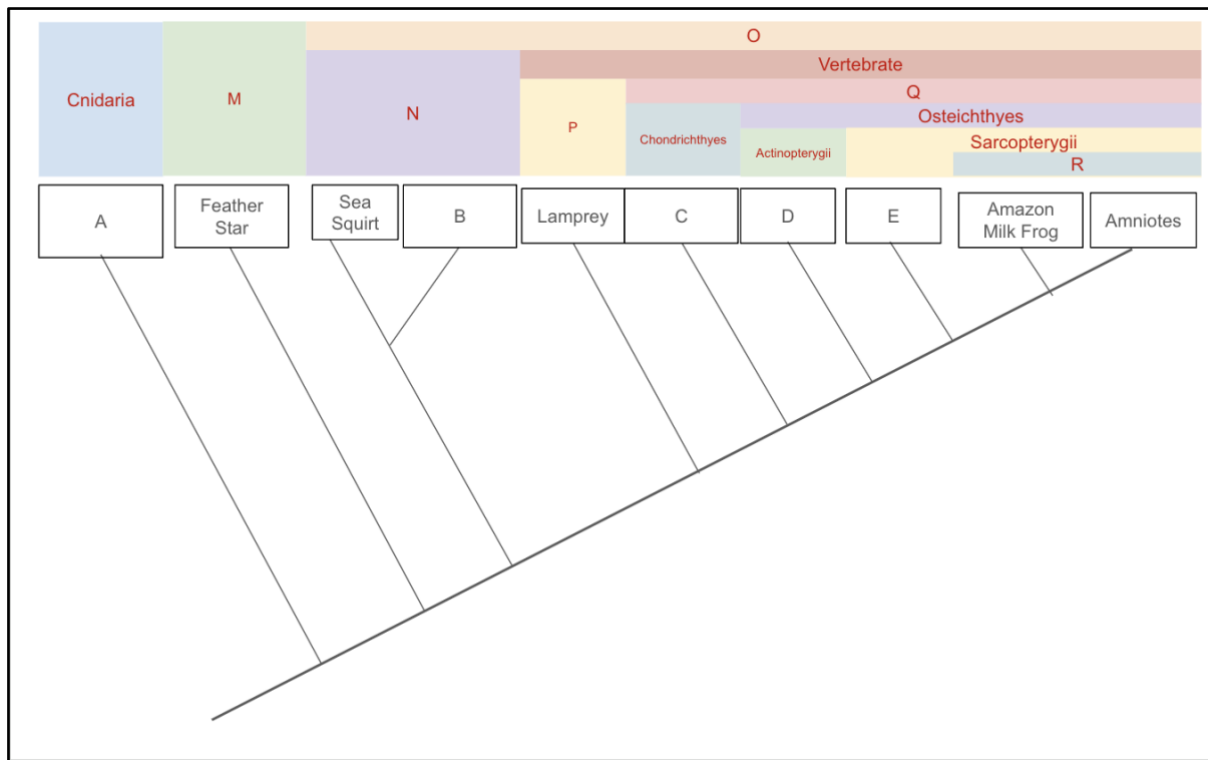

Figure 2: Ryan's two phylogenetic trees



Let's help Kelly and Ryan match the animal specimens to their corresponding numbers and letters.

**Q1.** Match the following animal specimens to the number and letter they represent. Enter your answer by **entering the corresponding number and then the corresponding letter to each row**. Do not leave any space. For example, if your answer is Animal 5 and Animal A, enter 5A. **(30 points)**

*(Enter a number and then a letter to each row.)*

<b>Animal Specimen</b>	<b>Number (1-16) + Letter (A-L)</b>
Crescent-caped lophorina	
Pacific sea nettle	
Opossums	

**Q2.** Match the following animal specimens to the number and letter they represent. Enter your answer by **entering the corresponding number and then the corresponding letter to each row**. Do not leave any space. For example, if your answer is Animal 5 and Animal A, enter 5A. **(30 points)**

*(Enter a number and then a letter to each row.)*

<b>Animal Specimen</b>	<b>Number (1-16) + Letter (A-L)</b>
Echidna	
Softshell turtles	
Greenland shark	

**Q3.** Match the following animal specimens to the number and letter they represent. Enter your answer by **entering the corresponding number and then the corresponding letter to each row**. Do not leave any space. For example, if your answer is Animal 5 and Animal A, enter 5A. **(30 points)**

*(Enter a number and then a letter to each row.)*

<b>Animal Specimen</b>	<b>Number (1-16) + Letter (A-L)</b>
Lungfish	
Slowworms	
Giant Larvacean	

**Q4.** Match the following animal specimens to the number and letter they represent. Enter your answer by **entering the corresponding number and then the corresponding letter to each row**. Do not leave any space. For example, if your answer is Animal 5 and Animal A, enter 5A. **(30 points)**

*(Enter a number and then a letter to each row.)*

Animal Specimen	Number (1-16) + Letter (A-L)
Sunfish	
Tasmanian Devil	
Asian Small-Clawed Otters	

On the next page of his information booklet, Ryan noticed several keywords (Figure 3) that he presumes matches to the letters above the phylogenetic trees.

Chordata	Sauropsida	Gnathostomes	Tetrapoda	Echinodermata
Monotremata	Eutheria	Marsupialia	Cyclostomes	Tunicata

Figure 3: Keywords

**Q5.** Match each letter on the top of the phylogenetic trees with their corresponding keywords. **(50 points)**

*(Enter a word from Figure 3 to each row.)*

Letter	Keyword
M	
N	
O	
P	
Q	



**Q6.** Match each letter on the top of the phylogenetic trees with their corresponding keywords. **(50 points)**

*(Enter a word from Figure 3 to each row.)*

<b>Letter</b>	<b>Keyword</b>
R	
S	
T	
U	
V	

# P31: Vanda Miss Joaquim

(150 points)

While drinking a cup of refreshing sugarcane juice, you stroll in the Singapore Botanic Gardens. The Singapore Botanic Gardens was founded in 1859 and is one of only three gardens in the world to be honoured as a UNESCO World Heritage Site. As you were walking, you stumbled into your friend Lionel who works there with NParks. You notice that he looks flustered. Maybe he needs a cup of sugarcane juice!

Upon asking him, Lionel reveals that he works in the Orchid Garden and needs help with one of his orchid plants.



Figure 1: Singapore National Orchid Garden

Singapore's national flower is an orchid called Vanda Miss Joaquim (Figure 2). (You may have noticed the orchid on the SBL website too!) Vanda Miss Joaquim was selected as the national flower on 15 April 1981 and was created by horticulturist Agnes Joaquim by crossing two orchid species, *Vanda teres* and *Vanda hookeriana*, in her garden. The orchid was named after her for her contribution to the creation of this flower. However, recent scientific research has revealed that these two orchid species are actually of the *Papilionanthe* genus, and thus the scientific name for Vanda Miss Joaquim has been changed to *Papilionanthe Miss Joaquim*. Nonetheless, the flower is still commonly called Vanda Miss Joaquim.



Figure 2: Vanda Miss Joaquim

Most commercial orchids are tetraploids, and so are these hybrids. During meiosis, each of the four homologous chromosomes associate randomly with each other forming two homologue pairs. Hence, each daughter cell receives two of the four homologues. Orchids are the most diverse family of Angiosperms and belong to the family Orchidaceae. They have colourful blooms and fragrances to attract insects for pollination. However, orchids are not immune to pests, and often are infested by aphids and caterpillars.

He recently discovered that one of the *Arachnis hookeriana* orchid plants in the Singapore Botanic Gardens was immune to aphids. Upon investigation, he discovered a dominant gene *A* in the plant which confers resistance to aphids by secreting neem oil which repels aphids. This plant has the genotype *AAaa* at its gene locus. Lionel also discovered that while most of the *A. hookeriana* plants were *aaaa*, some of the neighbouring *A. hookeriana* plants have the genotype *Aaaa* but do not have any resistance to aphids. He hence deduces that at least two dominant *A* alleles are required for resistance.

Lionel intends to select for this gene *A* by crossing different *A. hookeriana* plants together. He does so by first placing a toothpick under the anther to extract the pollen from one plant, then pushing the pollen into the stigma of the other plant.

**Q1.** Lionel crossed several orchid plants together based on the table below. Crossing of the parents produces the F1 (first filial) generation. The F1 generation is then crossed with itself to obtain the F2 generation and so on. Indicate the earliest generation that he can obtain an *AAAA* plant in the following crosses. If you think that it can never be obtained, leave your answer as *-1*.

**(40 points)**

*(Enter the correct answer to each row. Leave your answer as the filial generation in short form i.e. F1, or F2, or F3...)*

<b>Cross</b>	<b>Earliest generation where <i>AAAA</i> can be obtained</b>
<i>Aaaa</i> self-cross	
<i>AAaa</i> self-cross	
<i>Aaaa</i> x <i>aaaa</i>	
<i>AAaa</i> x <i>Aaaa</i>	

**Q2.** If Lionel were to test cross a *A. hookeriana* plant with genotype *AAaa*, what is the probability of obtaining an *Aaaa* offspring plant in the F1 generation? **(20 points)**

*(Enter your answer as a decimal correct to 3 s.f.)*

**Q3.** Lionel then decided to cross a *AAaa* plant with an *Aaaa* plant. What is the probability of getting an offspring plant that is resistant to aphids in the F1 generation? **(30 points)**

*(Enter your answer as a decimal correct to 3 s.f.)*

**Q4.** Lionel wishes to obtain pure-bred AAAA plants. He randomly picked two aphid-resistant plants from the F1 generation in **Q3** and crossed them. What is the probability of obtaining a pure-bred AAAA plant? **(40 points)**

*(Enter your answer as a decimal correct to 3 s.f.)*

Hybrid orchids can be produced by crossing two different species of orchids together. The pollen of one species of orchids is transferred to the stigma of another species of orchid, producing a hybrid of both species. Fertilisation occurs in a similar manner to other angiosperms. The pollen grain contains a generative cell and a tube cell, the latter of which grows into the style leading the way for the generative cell. The generative cell divides by mitosis forming two sperms. As the pollen tube enters the ovule through the micropyle, one sperm fertilises the egg situated between the synergids while the other fertilises the polar nuclei. The polar nuclei are each formed when the meiotic product in the female plant undergoes mitosis to produce two polar nuclei. The embryo then germinates after imbibition to form an orchid hybrid plant.

While most orchids are either diploids or tetraploids, there have been reports of extremely rare cases of orchids with higher ploidy levels. Lionel artificially bred two species of orchid with higher ploidy levels by inducing non-disjunction using colchicine. One species of the orchid is decaploid ( $10n$ ) while the other is an octoploid ( $8n$ ).

**Q5.** Lionel transferred the pollen grain from the decaploid ( $10n$ ) species to the stigma of the octoploid species of orchid ( $8n$ ). Indicate the ploidy of the resultant endosperm and embryo as a multiple of  $n$ . **(20 points)**

*(Enter your answer to each row as a multiple of  $n$ . For example, if you think that it is diploid, leave your answer as  $2n$ . If you think that the ploidy level is a decimal, leave your answer to 1 d.p. like  $3.5n$ . If you think there are extra copies of a chromosome, leave your answer as the sum of a multiple of  $n$  and an integer. For example, if you think there is trisomy 21 in a diploid, leave your answer as  $2n + 1$ .)*

Tissue	Ploidy ( $n$ )
Endosperm	
Embryo	



# P32: Emma is crying again!

(150 points)

After Emma cried over spilling milk over her data, she promised never to drink milk in the lab again (which she should not have anyway). However, she was quite happy in the lab today as she recently discovered an assay called Electrophoretic Mobility Shift Assay (EMSA) which has a similar name to hers.

Electrophoretic Mobility Shift Assay (EMSA) is an assay to study the interactions of proteins to different segments of DNA, for example with transcription factors. The protein of interest is first added to the radioactively labelled DNA fragments, and then the sample is subjected to electrophoresis. This operates on the principle that DNA fragments bound to proteins will be retarded and thus migrate more slowly than the free linear DNA fragments. Thus, the radioactively labelled DNA can be imaged by radiographic techniques.

Emma needs to determine where the sequence coding for the DNA-binding domain of a newly-discovered transcription factor TFIIN is located in the gene. She constructs five gene constructs from 5' to 3' as seen below and transforms them separately into *E. coli* to form proteins 1 to 5 from each gene construct 1 to 5 respectively as seen in Figure 1.

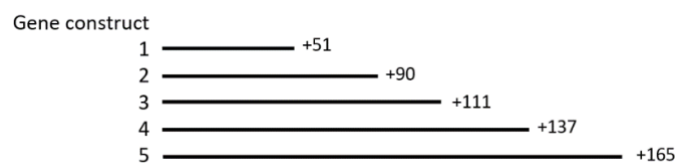

Figure 1: Gene constructs

The transcription factor is known to bind to a 100bp DNA fragment. The DNA fragment was radioactively labelled, mixed with the various combinations of proteins as seen in the table in Figure 2, and then subjected to an EMSA.

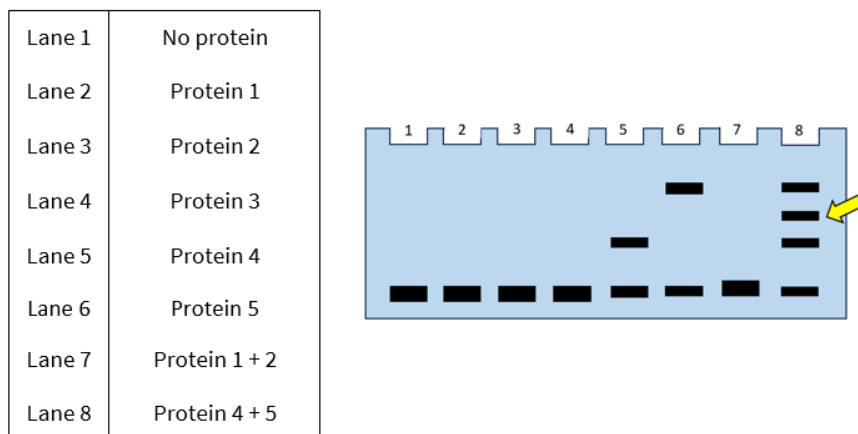

Figure 2: EMSA for TFIIN investigation

**Q1.** Within which region can the DNA-binding domain of TFIIN be found? **(10 points)**

*(Select the correct option.)*

- A. Upstream of -1
- B. -1 to +51
- C. +51 to +90
- D. +90 to +111
- E. +111 to +137
- F. +137 to +165
- G. Downstream of +165
- H. Cannot be deduced

**Q2.** An additional band can be seen in Lane 8 as indicated by the yellow arrow. Emma made several hypotheses regarding its formation. Which of the following hypotheses are plausible? **(30 points)**

*(Select all correct options.)*

- A. The second band is a result of alternative splicing.
- B. The second band is a result of the protein requiring post-translational modification which *E. coli* is unable to carry out.
- C. The second band is a result of dimerism of proteins 4 and 5 forming a heterodimer.
- D. The second band is a result of all the protein 5 added to the well to be longer than usual.
- E. The second band is a result of the protein 5 denaturing.
- F. The second band is a result of poor experimental technique introducing hair keratin (a protein) into the sample.

Emma also needs to investigate the interaction between unknown DNA-binding proteins A, B, C, and a DNA fragment. She is also trying to investigate the interactions of X, Y, and Z, which are respectively an antibody that binds to C, a DNA fragment that binds strongly to A, B, and C, as well as a mutated DNA fragment. She adds one of X, Y or Z to lanes 8 to 10, in addition to A, B, C and the DNA fragment. None of these are radioactively labelled.

The DNA fragment was radioactively labelled, mixed with various combinations of proteins as seen in Figure 3, and then subjected to an EMSA. As the gel electrophoresis takes 1h, she walked out of the lab so that she could drink her milk. Unfortunately, Emma spilt milk on her lab notebook again, covering up what she had added into Lanes 8-10. She insisted that it was not her fault as she was drinking milk outside of the lab, which was permitted. Nevertheless, she knows she has to use her results to figure out what she had added to Lanes 8-10.

Lane 1	DNA Ladder (250bp, 500bp, 750bp, 1000bp, 2000bp, 2500bp, 3000bp, 3500bp, 4500bp, 5000bp)
Lane 2	DNA fragment only
Lane 3	DNA fragment + A
Lane 4	DNA fragment + B
Lane 5	DNA fragment + A + B
Lane 6	DNA fragment + B + C
Lane 7	DNA fragment + A + B + C
Lane 8	DNA fragment + A + B + C + 
Lane 9	DNA fragment + A + B + C + 
Lane 10	DNA fragment + A + B + C + 

Figure 3: DNA fragment and proteins added in the respective lanes for EMSA. Milk was spilt on Lanes 8-10 obscuring their information.

The results of the EMSA are shown in Figure 4.

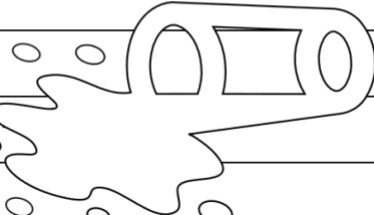
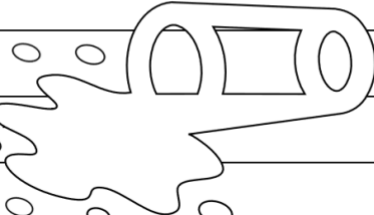
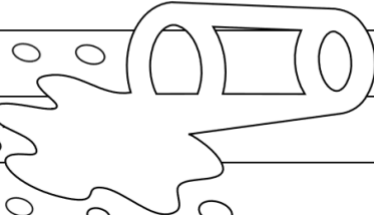
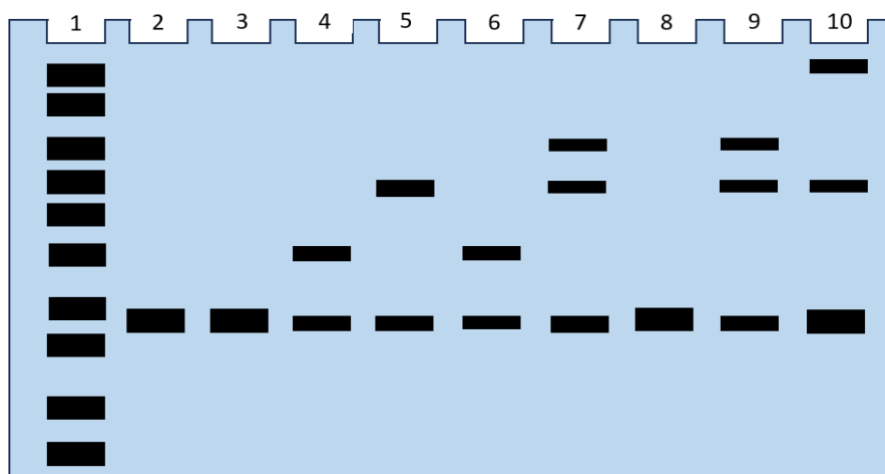

Figure 4: EMSA for unknown DNA-binding proteins

**Q3.** Indicate whether the following statements regarding the EMSA in Figure 3 are True or False. **(50 points)**

*(Mark each statement as true or false.)*

- The DNA fragment is about 3200bp.
- Just like in SDS-PAGE, the samples were heated with SDS and  $\beta$ -mercaptoethanol to around 100°C before the samples were loaded into the wells for EMSA.
- The gene that codes for the protein that binds to the DNA fragment in Lane 4 is approximately 1100bp long.
- The binding efficiency of Protein C is relatively low.
- If the lane only contained the DNA fragment + A + C, the result would look like Lane 4.

**Q4.** Help Emma match the letters (A, B, C, X, Y, Z) to the correct questions. **(60 points)**

*(Enter the correct letters to the correct rows. If there is more than one letter, input them in alphabetical order or in the order as specified.)*

Question	Letter(s)
Which protein(s) (A, B, C) can bind to the DNA fragment by itself?	
Which protein (A, B, <b>or</b> C) is most likely to be RNA polymerase?	
What is the order of protein binding of A, B and C? <i>(Indicate the order of binding by typing in the first protein that binds to the DNA fragment, the next protein that binds to this protein, and the last protein that binds to the second one.)</i>	
Which unknown (X, Y, <b>or</b> Z) was added to lane 8?	
Which unknown (X, Y, <b>or</b> Z) was added to lane 9?	
Which unknown (X, Y, <b>or</b> Z) was added to lane 10?	

Maybe Emma should go for a refresher on safety in the lab with her professor?

# P33: Despicable Me

(200 points)

Mitogen-activated protein kinases (MAPKs) are a type of protein kinase involved in directing cellular responses to extracellular signals. For example, in mammals, many MAPKs are involved in cell proliferation and mobility coordination. AtMPK10 is a type of MAPK present in *Arabidopsis* plants. To investigate its activity in an *Arabidopsis* plant called “Subject 1”, we use a glucuronidase (GUS) reporter. The reporter gene codes for the  $\beta$ -glucuronidase enzyme which can convert non-coloured or non-fluorescent substrates into coloured or fluorescent products, allowing for easy visualisation. Hence, the colour intensity can be used as a surrogate for AtMPK10 activity. The results are seen in Figure 1.

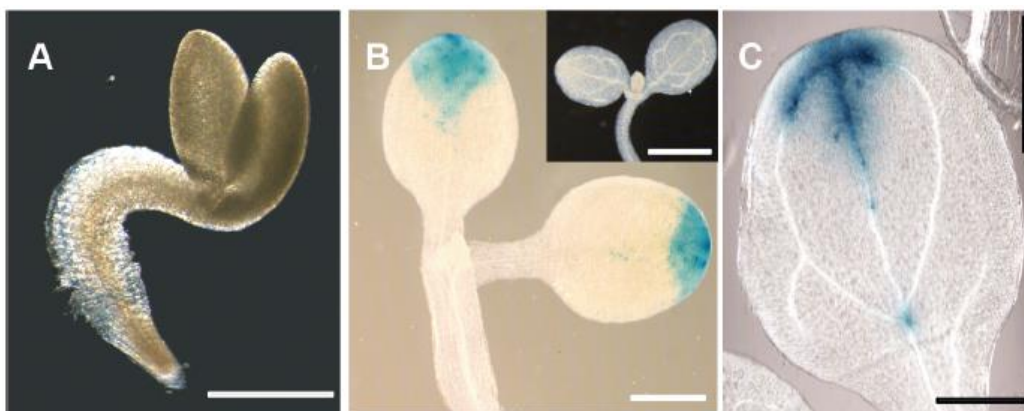

Figure 1: (A) A seedling a day post-germination. (B) A seedling's cotyledons 3 days post-germination (top-right corner: a wild-type seedling with no GUS reporter). (C) One cotyledon for a seedling 12 days post-germination.

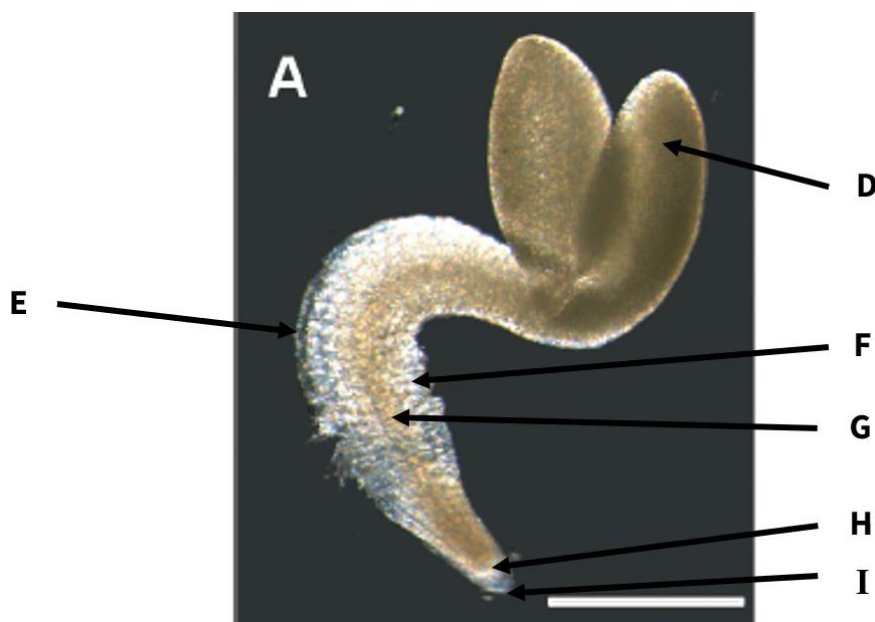

Figure 2: Enlarged labelled diagram of Figure 1A

We then conducted RT-PCR and ran the results on agarose gel with radioactive probes as listed in Figure 3.

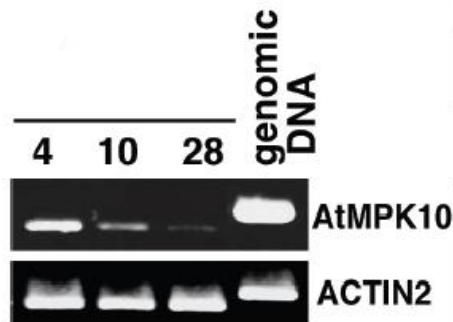

Figure 3: RT-PCR results. Numbers represent the number of days post-germination.

**Q1.** Match the parts (D-I) in Figure 2 to the correct descriptions below. If there is no such part, enter *None*. Note that not all letters may be used, and some letters may be used more than once. However, there is only one answer to each description. **(40 points)**

*(Match the correct letter to each row.)*

Description	Part (D-I)
Protoxylem	
Quiescent centre	
Secretes mucilage	
Endosperm	

**Q2.** Indicate whether the following statements are true or false. **(40 points)**

*(Mark each statement as true or false.)*

- A. The cells in I in Figure 2 help determine whether the radicle grows upwards or downwards.
- B. AtMPK10 is active 24 hours after a seedling germinates.
- C. Active AtMPK10 has an apical distribution.
- D. Over time, AtMPK10 activity spreads across the lamina.

**Q3.** Indicate whether the following statements are true or false. **(40 points)**

*(Mark each statement as true or false.)*

- A. AtMPK10 activity slowly becomes restricted to cotyledon veins.
- B. As the seedling grows, AtMPK10 expression falls.
- C. The venation development in the cotyledons post-germination allows for the sugars made during photosynthesis to be transported from the cotyledons to the rest of the seedling.
- D. AtMPK10 tends to be active where leaf veins branch.

After that, we performed a yeast 2-hybrid (Y2H) screening to find out the potential binding partners that AtMPK10 has. The results are seen in Figure 4. Note that AtMKK2 and MKK2 are considered synonymous.

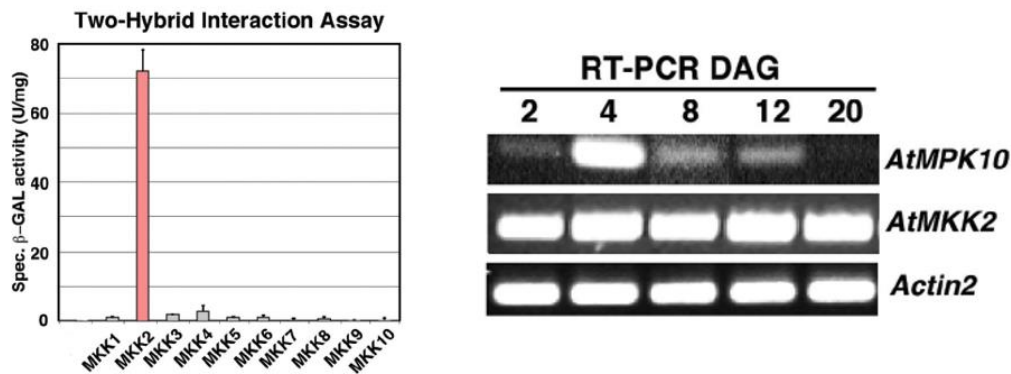

Figure 4: Y2H assay and RT-PCR results. DAG represents days after germination

**Q4.** Match the following expression levels to the number of days after germination (DAG). (30 points)

(Enter a whole number to each row.)

Expression level (normalised to highest value)	DAG
0.00	
0.15	
1.00	

To investigate some of the MAPK kinases *Arabidopsis* has, we carried out further studies. Figure 5 shows a Y2H assay conducted under different NaCl concentrations with the addition of different MAPKs, while Figure 6 shows a Western blot gauging the activity of MPK4 and MPK6 after the plant is exposed to cold stress.

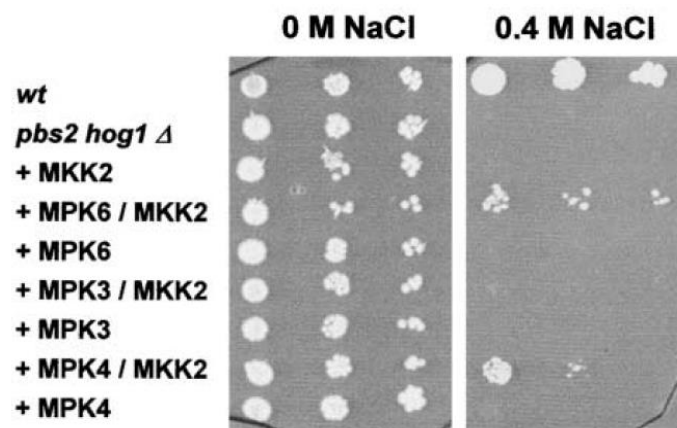

Figure 5: Y2H assay of different MAPKs. *wt* represents wildtype, while *pbs2 hog1 Δ* represents an osmosensitive mutant.

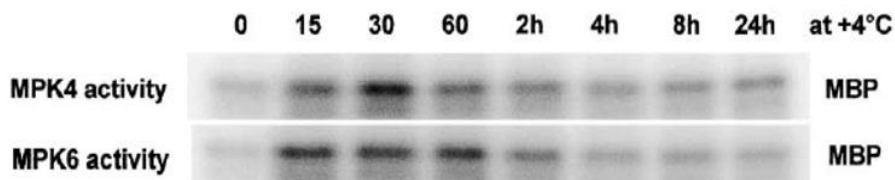

Figure 6: Western blot assay on MAPK4 and MAPK6 activities. MBP as substrate. Intensities are to scale.

**Q5.** Which of the following MAP kinases interact with MKK2 to allow for salt tolerance? **(10 points)**

*(Select all correct options.)*

- A. MPK3
- B. MPK4
- C. MPK6

**Q6.** Indicate whether the following statements are true or false. **(40 points)**

*(Mark each statement as true or false.)*

- A. The assays with added MPK or MKK in Figure 5 were conducted with the *pbs2 hog1 Δ* mutant instead of the wildtype.
- B. MPK6 is mobilised before MPK4 to help deal with cold stress.
- C. The plant acclimates to cold stress after being in the cold for at least 4h.
- D. MPK4 is more active than MPK6 when the plant is exposed to the cold for an hour.



# P34: Character Displacement

(120 points)

*Pogoniulus bilineatus* and *Pogoniulus subsulphureus* are 2 closely related species. *Pogoniulus bilineatus* are typically found in more open habitats and *Pogoniulus subsulphureus* are found in dense forests. Their geographical range tended not to have overlapped in the past (allopatry) but may have started to coexist in areas (sympatry) where pristine rainforest has been degraded due to deforestation. This had led to morphological and behavioural changes in both species. Bird songs are typically sung by male birds to attract mates or signal territorial ownership to their conspecifics.

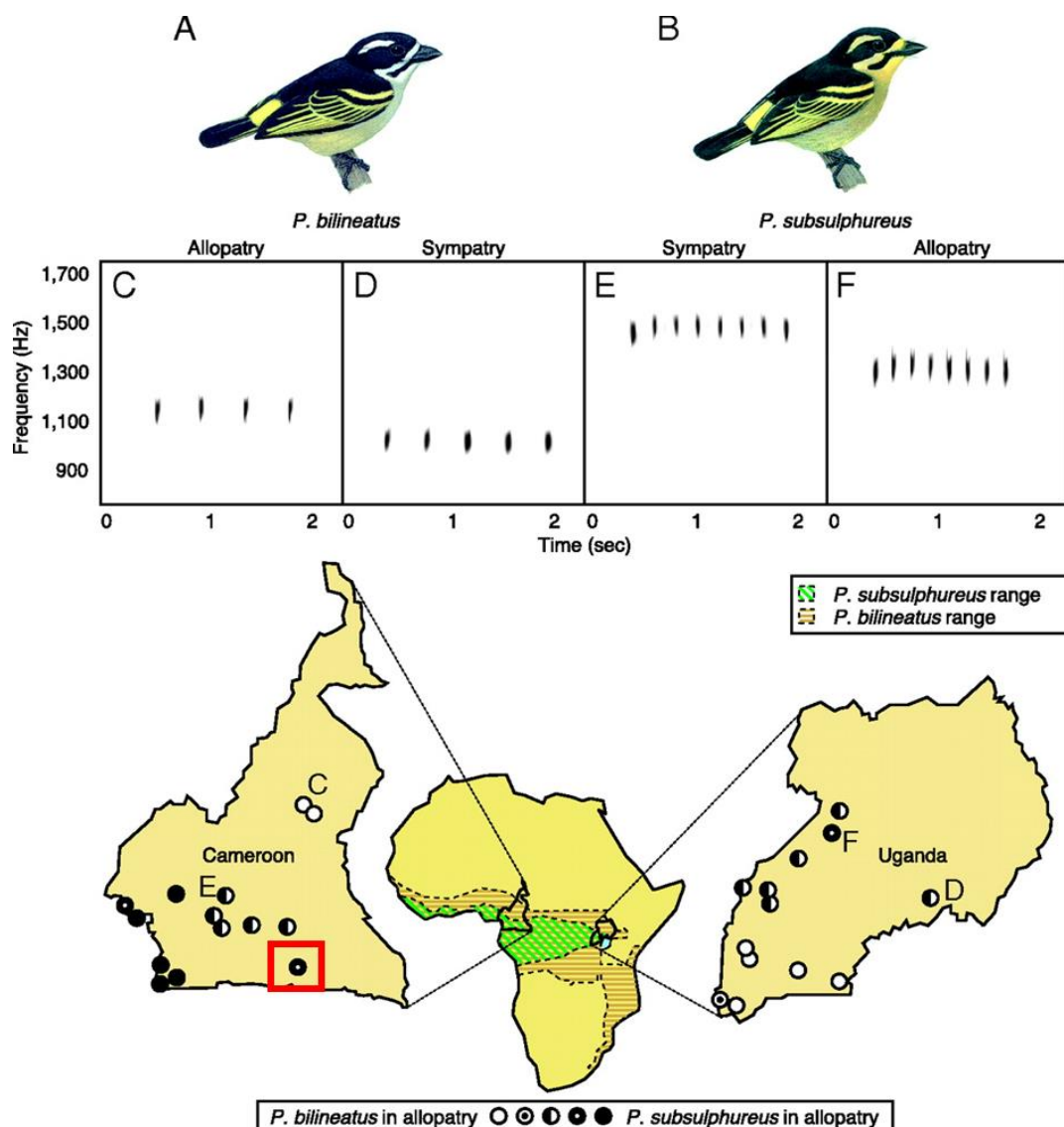

Figure 1: (C–F) Spectrograms of bird songs. The Africa map illustrates the species' distributions. Each circle represents a habitat where either one or both species are present. Site locations are illustrated for *P. bilineatus* in allopatry (white circles); *P. subsulphureus* in allopatry (black circles); *P. subsulphureus* common, *P. bilineatus* rare in sympatry (black circles with white dots); *P. bilineatus* common, *P. subsulphureus* rare in sympatry; and both species common in sympatry (half-filled circles).

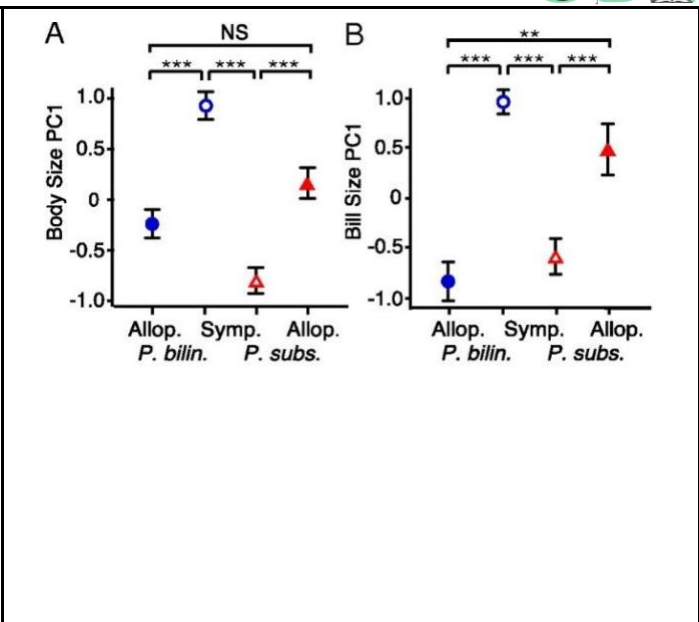
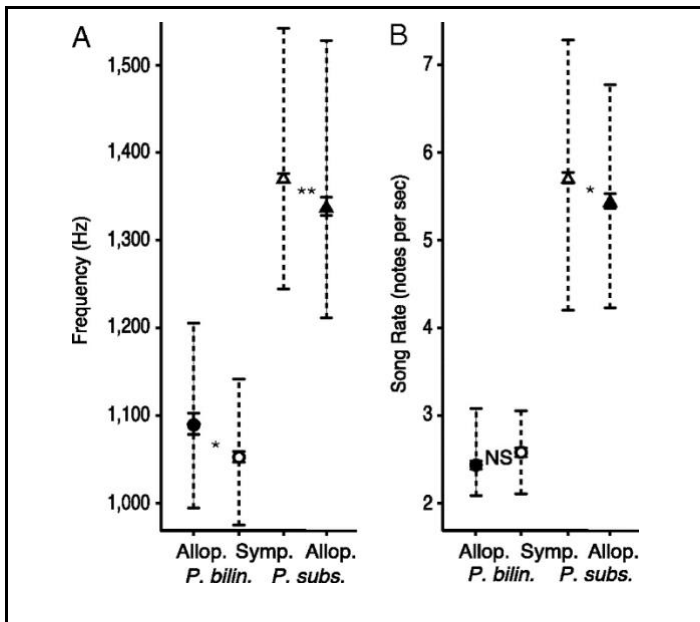

Figure 2: Frequency and song rate of *P. subsulphureus* and *P. bilineatus* in sympatry and allopatry.

Figure 3: Body size and bill size of *P. subsulphureus* and *P. bilineatus* in sympatry and allopatry.

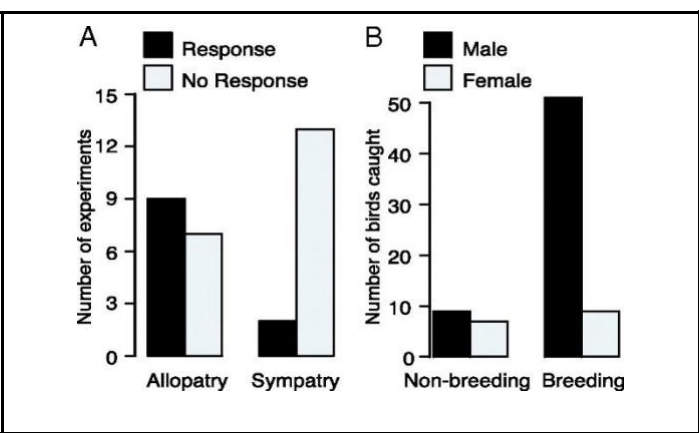
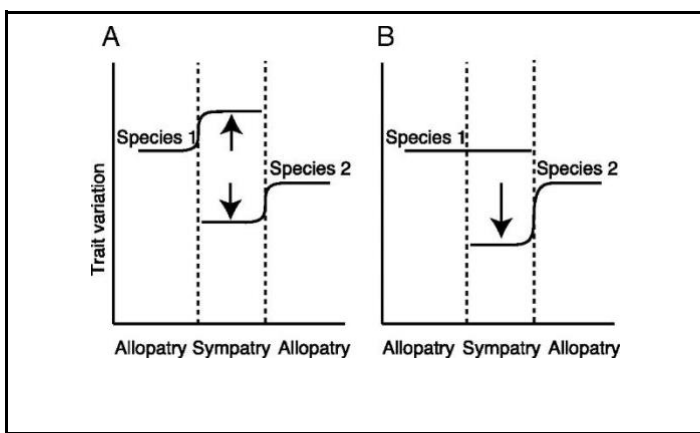

Figure 4: Effect of evolutionary-related, ecologically-similar heterospecifics on evolution of traits of its counterpart when in sympatry may vary based on relative abundance.

Figure 5:  
A: Synthetic mean heterospecific songs were played and the number of responses were measured.  
B: Synthetic mean conspecific songs were played and the number of birds caught were measured.

**Q1.** Indicate whether the following statements are true or false. **(40 points)**

(Mark each statement as true or false.)

- A. In both Cameroon and Uganda, there are more habitats with birds in sympatry than allopatry.
- B. Both species had a change in song rate from its allopatric condition when in sympatry.
- C. Frequency of notes is likely a more significant differentiator in song types compared to song rate.
- D. The data supports the acoustic adaptation hypothesis.

**Q2.** Indicate whether the following statements are true or false. **(40 points)**

(Mark each statement as true or false.)

- A. Frequency of songs is generally positively correlated with song rate.
- B. An increase in body and bill size is correlated with a lower pitch when comparing different populations of the same species.
- C. Deforestation is leading to phenotypic convergence between *Pogoniulus bilineatus* and *Pogoniulus subsulphureus*.
- D. *Pogoniulus bilineatus* and *Pogoniulus subsulphureus* in allopatry had significantly different body size and bill size.

**Q3.** Indicate whether the following statements are true or false. **(40 points)**

(Mark each statement as true or false.)

- A. The reproductive barrier between *Pogoniulus bilineatus* and *Pogoniulus subsulphureus* is stronger in allopatry than in sympatry.
- B. *Pogoniulus subsulphureus* in the habitat which is boxed in red in Figure 1 is species 2 in Figure 4B for the area of sympatry.
- C. Vocalisation of bird songs where the 2 birds are in sympatry are used to mark territorial boundaries against heterospecifics (e.g. *Pogoniulus bilineatus* warding off *Pogoniulus subsulphureus*).
- D. The males are singing during the breeding season primarily to attract mates.

# P35: Replication: A Closer Look

(190 points)

## Overview of DNA Replication

DNA replication occurs semi-conservatively, with each parental strand serving as a template for the synthesis of a new daughter strand. As DNA polymerase can only synthesise DNA in the 5'-to-3' direction, this creates Okazaki fragments, which are short segments of nucleotides formed during DNA replication (Figure 1).

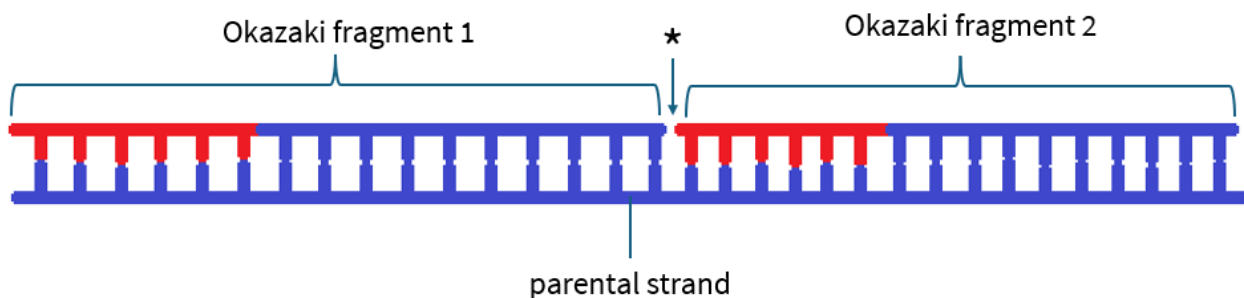

Figure 1: DNA replication. Blue: DNA, Red: RNA

**Q1.** Which statement about DNA replication is true? (20 points)

(Select the correct option.)

- A. In *E. coli*, the Okazaki fragments on the lagging strand are synthesised in the same direction in which the replication fork is progressing.
- B. The synthesis of the lagging strand “lags” behind that of the leading strand as the DNA polymerase that synthesises the lagging strand has a slower rate of synthesis (i.e. fewer nucleotides incorporated per second).
- C. After the removal of RNA primers but prior to the action of DNA ligase, there will be a gap in the sugar-phosphate backbone at the position marked with an asterisk (\*) between Okazaki fragments 1 and 2 in Figure 1.
- D. When fully synthesised, a single daughter DNA strand comprises parts that were synthesised continuously and parts that were synthesised discontinuously during DNA replication.

## Back to Where It All Started: Finding the Origin

DNA replication begins at specific DNA sequences called origins of replication. Two-dimensional DNA electrophoresis can be used to determine the position of the origin of replication. After restriction digest, replicating DNA molecules are separated by size in the first dimension, and then by shape in the second dimension. Results of one such experiment are shown in Figure 3.

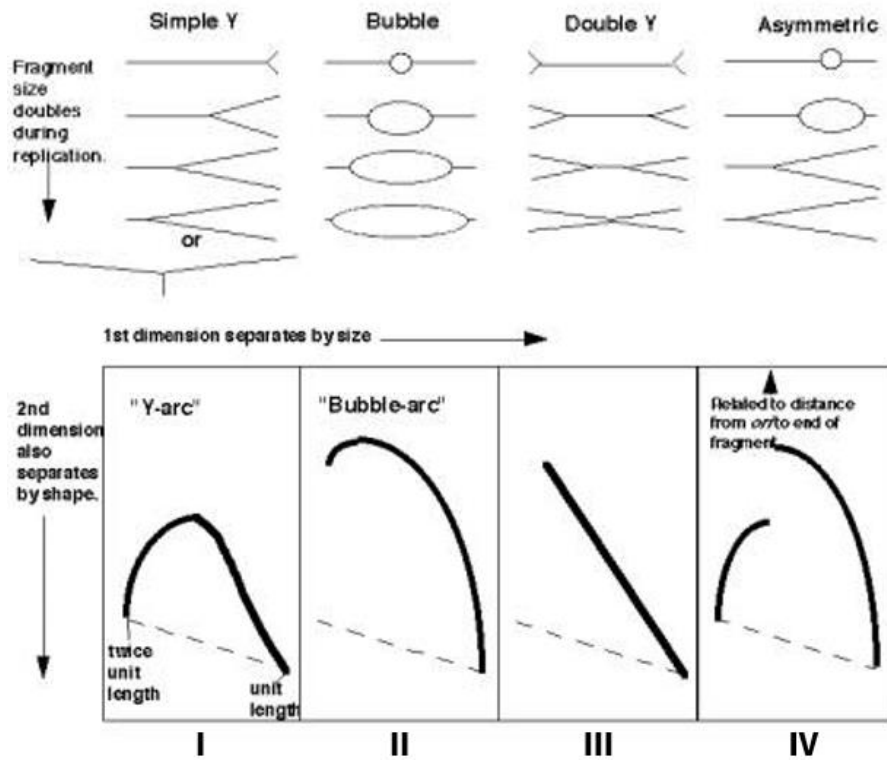

Figure 2: Principles of 2-dimensional DNA electrophoresis. The corresponding gel (I, II, III, IV) is shown below each type of DNA fragment.

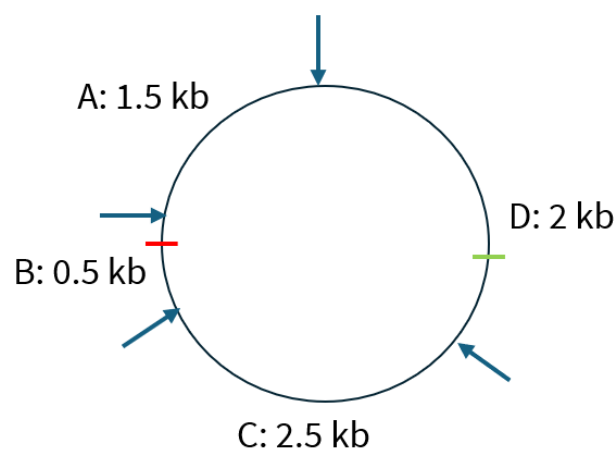

Figure 3: Restriction map of plasmid containing a single origin of replication and a single terminator sequence. Arrows: Restriction sites, Green hatch mark: Origin of replication, Red hatch mark: Terminator sequence

**Q2.** Match the fragments (A, B, C, D) in Figure 3 with their corresponding gel results (I, II, III, IV) in Figure 2. Note that each Roman numeral may be used more than once or not at all. **(40 points)**  
*(Match the correct Roman numerals to the correct letters.)*

Fragment	Gel Result
A	
B	
C	
D	

## Cell Replication

The cell cycle, the process by which a cell replicates its DNA and divides into two genetically identical daughter cells, consists of the  $G_1$ , S,  $G_2$  and M phases. Three experiments were conducted to determine the length of each phase of the cell cycle for a culture of a hypothetical microbe. In experiment 1, the number of viable cells in a growth medium were counted at 20-hour intervals (Figure 4). In experiment 2, the cells were first briefly exposed to radioactive thymidine, washed, and re-incubated with non-radioactive thymidine. The percentage of mitotic cells that were labelled were counted at one-hour intervals (Figure 5). In experiment 3, microscopic observation showed 10% of cells to be in M phase.

Time/h	log(number of cells)
0	1
20	1.2

Figure 4: Experiment 1 Results.

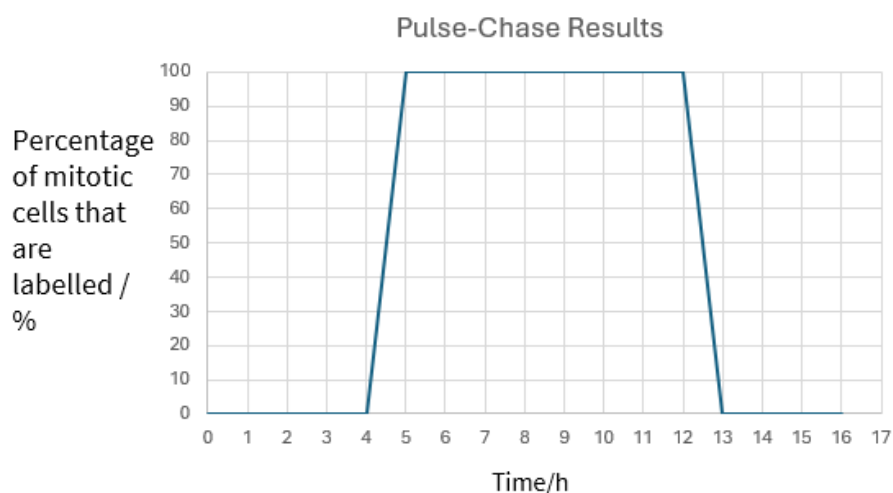

Figure 5: Experiment 2. Time = 0 h indicates the time when radioactive thymidine was added.



**Q3.** To the nearest whole number, what is the total duration of the entire cell cycle? **(20 points)**

*(Select the correct option.)*

- A. 9 h
- B. 18 h
- C. 26 h
- D. 30 h

**Q4.** Calculate the duration of the M phase in hours. Round off your answer to the nearest whole number. **(10 points)**

*(Enter your answer correct to the nearest whole number. Do not include any units.)*

**Q5.** Calculate the duration of the  $G_1$ , S and  $G_2$  phases in hours. Round off all answers to the nearest whole number. **(60 points)**

*(Enter your answer correct to the nearest whole number to each row.)*

<b>Phase of Cell Cycle</b>	<b>Duration in hours</b>
$G_1$	
S	
$G_2$	

## ***E. coli* Replication**

Replication of the entire *E. coli* genome takes 40 min to complete. Under normal circumstances, regulatory mechanisms ensure that the origin of replication is only initiated once during each round of cell division, coupling the process of DNA and cell replication. In *E. coli*, one such mechanism is the methylation of the DNA sequences at the origin of replication. Immediately after DNA replication, at the origins of replication, the daughter strands are unmethylated, whereas the parental strands are methylated. The next round of DNA replication can only be re-initiated after the daughter strands are methylated, which only occurs a while after DNA replication is complete.

A student cultured *E. coli* in a particular growth medium, and determined the generation time to be 20 min. The student observed the replicating *E. coli* genome under the microscope and drew the structure shown in Figure 6.

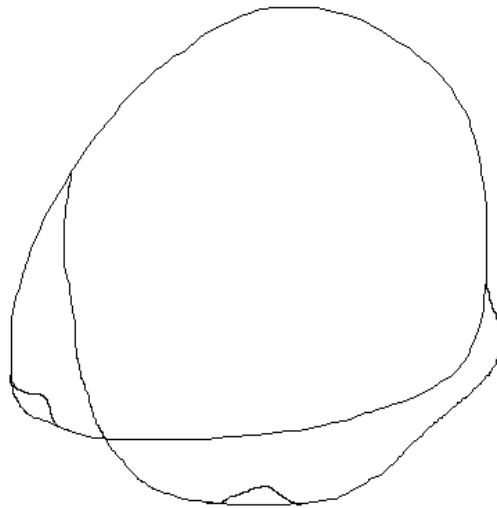

Figure 6: *E. coli* genome.

**Q6.** Indicate whether the following statements regarding replication of the *E. coli* genome are true or false. **(40 points)**

*(Mark each statement as true or false.)*

- A. The students' observations in Figure 6 are due to DNA supercoiling (the twisting of the DNA double helix onto itself).
- B. A mutation in topoisomerase can explain the results, as it prevents concatenated DNA (interlocked DNA circles) from being resolved.
- C. The results indicate the presence of chromosome dimers.
- D. It is likely that the inhibition of DNA replication initiation is overcome in *E. coli* cells growing in this medium.



## P36: T6

(210 points)

*Construction of Changi Airport's T5 is starting in 2025. I wonder when is T6 going to be built?*

In mammalian X-chromosome inactivation (XCI), one of two X chromosomes is randomly inactivated early during embryonic development as a mechanism for dosage compensation of sex chromosome genes. One X chromosome becomes inactivated to form the Barr body, and only genes on the other X chromosome are expressed. This XCI process is regulated by the Xist (X-inactive specific transcript) RNA. Once XCI has occurred, this epigenetic pattern is faithfully inherited by all progeny cells.

Calico cats have both orange and black patches, which occurs due to XCI. Hence, some patches will be orange due to expression of the allele which codes for orange fur, while the other patches will be black due to the other allele which codes for black fur.



Figure 1: Calico Cat

**Q1.** You are surprised to find that the calico cat you have has a penis. Which of the following statements are plausible explanations for the observed phenotype? Indicate True if the explanation is plausible and False if it is not plausible. **(50 points)**

*(Mark each statement as true or false.)*

- The genotype of the cat is XXY.
- Non-disjunction of sex chromosomes in anaphase II occurred in the germ cell that gave rise to the egg which formed the cat.
- While the cat has XY genotype, unequal crossing-over occurred in oogenesis in the mother, which resulted in two genes that code for fur colour (one coding for orange pigment and one coding for black pigment) being found on the X chromosome.
- The cat has XX genotype but also has congenital adrenal hyperplasia, so the adrenal gland produces high levels of testosterone.
- The cat has XY genotype but the Y chromosome happens to carry the gene that codes for fur colour.

XCI is a form of sex chromosome gene dosage compensation to balance the levels of X-linked gene products between both sexes. The mechanism of dosage compensation can differ greatly between species. In marsupial mammals like koalas, the paternally-derived X chromosome is specifically inactivated, while in the fruit fly *Drosophila melanogaster*, the level of gene expression on X chromosomes in males is doubled. Meanwhile, in the roundworm *Caenorhabditis elegans*, the level of gene expression on X chromosomes on hermaphrodites is halved.

The difference in mechanisms can be determined by carrying out sodium dodecyl-sulfate polyacrylamide gel electrophoresis (SDS-PAGE) of the glucose-6-phosphate dehydrogenase (G6PD) enzyme. The G6PD enzyme is encoded by a single gene found on the X chromosome. This gene has two alleles, one  $A_1$  allele, which codes for a G6PD isozyme, and a mutant  $A_2$  allele, which codes for a different isozyme, due to 102 fewer nucleotides compared to the  $A_1$  allele.

You decided to conduct a test on six different organisms to distinguish their dosage compensation mechanisms. Each organism had the  $A_1$  allele on one X chromosome and the  $A_2$  allele on the other X chromosome. You randomly extracted four cells from each organism and homogenised each cell separately. The G6PD enzymes of each cell sample were extracted and purified, and then subjected to SDS-PAGE. Assume all organisms are heterozygous for the G6PD gene where possible.

Figures 2 to 5 show the different possible SDS-PAGE results.

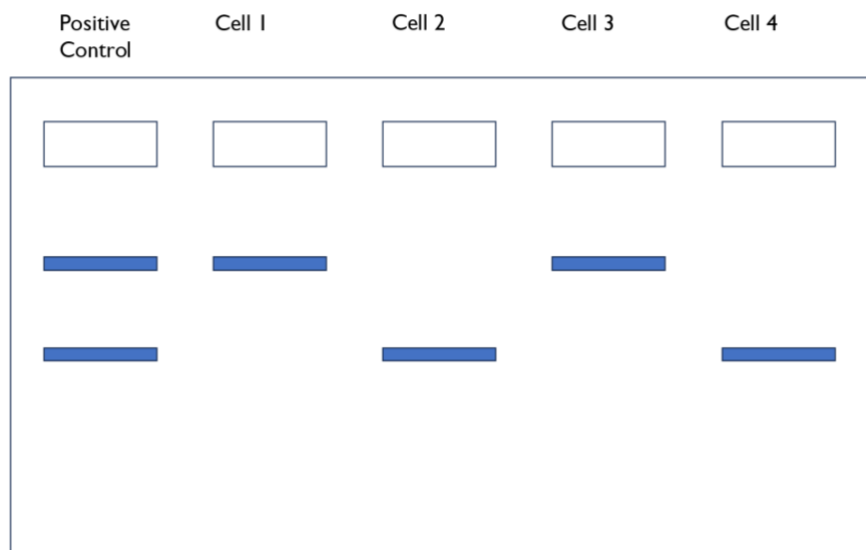

Figure 2

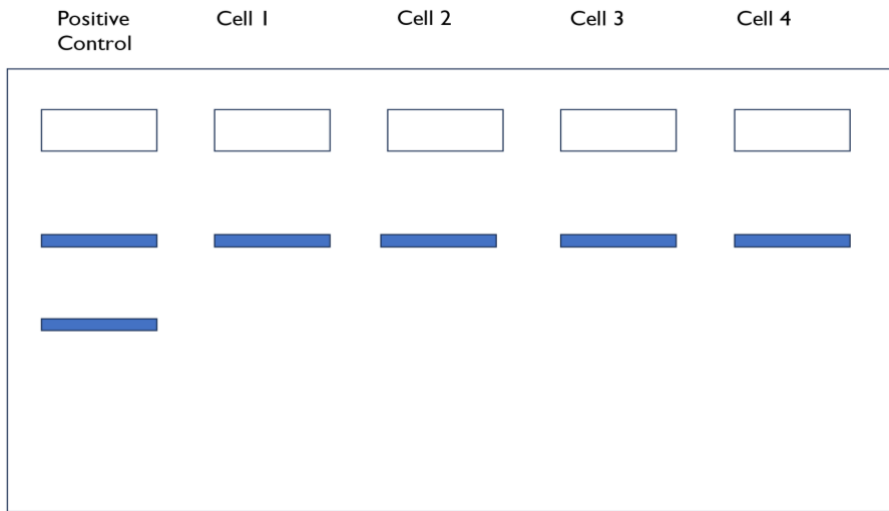

Figure 3

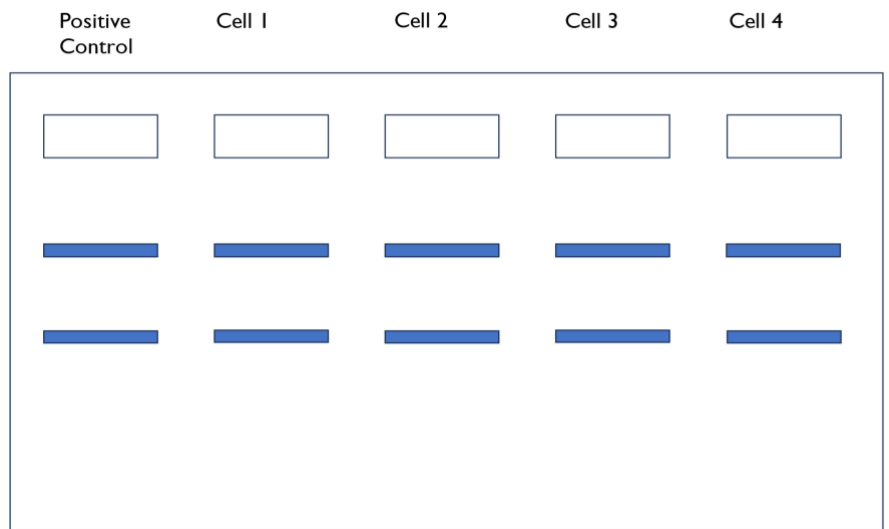

Figure 4

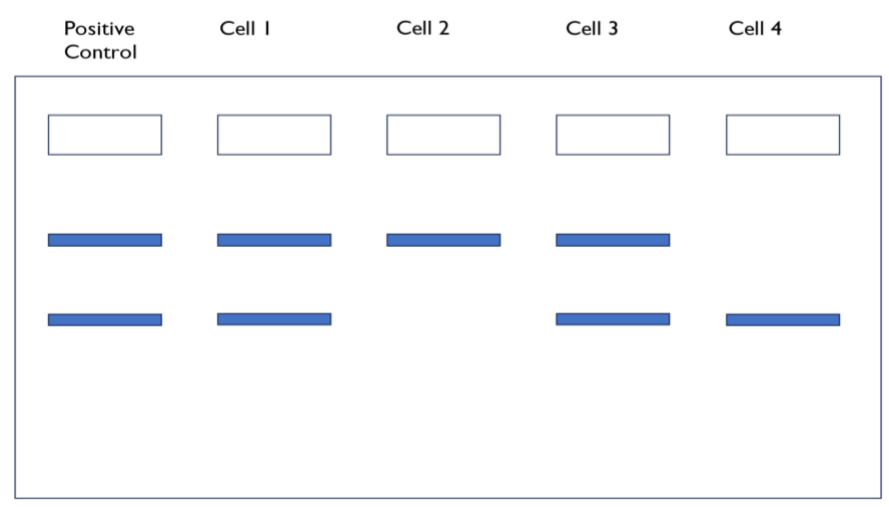

Figure 5

**Q2.** Indicate the expected SDS-PAGE results for the following organisms by indicating the correct figure numbers (2-5). Figure numbers may be used once, more than once or not at all. **(50 points)**  
(Match the correct number to the correct row.)

Organism	Expected Result (2-5)
Normal human female	
Human female with Turner syndrome	
<i>Caenorhabditis elegans</i> hermaphrodite	
Marsupial female	
<i>Drosophila melanogaster</i> female	

G6PD dimers are produced in cells. First, transcription and translation occur to produce the G6PD monomers. Two G6PD monomers dimerise to form a G6PD dimer, which is then secreted into the blood. Sometimes under certain conditions, the dimers can also dimerise forming tetramers.

**Q3.** If a woman has both alleles  $A_1$  and  $A_2$  for G6PD, what is the proportion of  $A_1A_1$  dimers found in her blood? **(20 points)**

(Enter your answer as a decimal correct to 3 s.f.)

XCI can occur for either the paternal or maternal chromosome. Which chromosome is inactivated is dependent on the X-inactive specific transcript (Xist) gene which encodes a lncRNA (long non-coding RNA). The X-chromosome that expresses the Xist gene is coated by the lncRNA, allowing it to be inactivated.

**Q4.** The inactivated X-chromosome is isolated from a cell. What is the easiest way for you to determine whether this inactivated X-chromosome is paternal or maternal? **(20 points)**

- A. Karyotype with staining
- B. Co-immunoprecipitation
- C. Restriction fragment length polymorphism (RFLP)
- D. Microarrays
- E. DNase-seq
- F. Sanger sequencing
- G. Yeast-2-hybrid
- H. Southern Blot

**Q5.** In general, the probability of XCI of either parental chromosome is 50%. If random XCI occurs at the 8-cell stage, calculate the probability that there are an equal number of cells expressing each X chromosome. **(20 points)**

*(Enter your answer as a decimal correct to 3 s.f.)*

**Q6.** Now assume that random XCI occurs at the 64-cell stage. Calculate the probability that there are between 30 and 34 cells (inclusive) with the paternal X chromosome expressed at the 64-cell stage. (Hint: You may find the use of a graphing calculator helpful.) **(30 points)**

*(Enter your answer as a decimal correct to 3 s.f.)*

Your professor posed a question regarding XCI at the 64-cell stage to the class for discussion:



At the 64-cell stage, is the proportion of cells with the paternal X chromosome expressed **likely to be closer to**, **equal to**, or **further from 50%** than that in the 8-cell stage?

Dr Jerome (The professor)

It's clearly closer to 50%. Since 8 is not a large sample size, the binomial distribution of proportion of cells with paternal X-chromosome expressed is not approximately normal by the Central Limit Theorem, so the proportion of cells with paternal X chromosome expressed is more likely to deviate from the mean for the 8-cell stage.



Owen



Alicia

Okay, I have no idea what Dr Jerome is saying. This is not possible to predict because X-chromosome inactivation is a random event so the likelihood is random. It's like saying if it is more likely for Owen or me to find an apple to feed on today. An apple a day keeps the doctor away; hope I can find one to keep Dr Jerome from asking such odd questions in the future.

I disagree with Owen and Alicia. The answer should be "equal to 50%". Since whether a cell has a paternal or maternal X chromosome expressed is a random, independent event, the mean and standard deviation of the normal distribution representing the proportion of cells with the paternal X chromosome expressed remains the same regardless of the stage where X-chromosome inactivation occurs.



Cervon



Yuting

Hey that's not fair! Cervon has a laptop to search for the answer! He may have gotten the correct answer, but his explanation is wrong! As the number of random, independent events of X-chromosome inactivation occurring increases, the observed number of cells with paternal X-chromosome expressed will not converge towards the expected number of cells with paternal X-chromosome expressed according to the Law of Large Numbers.

Hey! Don't blame him; we can use our laptops just like during the SBL! However, the answer is actually "further from 50%". We literally learnt this before in class! As the number of random, independent events (whether a cell has a paternal or maternal X chromosome expressed) increases, variance increases leading to greater likelihood of deviation from the mean.

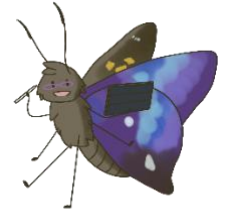

Le Xuan



Debraath

You all yap so much but the answer is trivial: Closer to 50%. This is because of the Law of Large Numbers. As the number of random, independent events of X-chromosome inactivation occurring increases, the proportion of cells with the paternal X chromosome expressed converges to the mean.

Actually, the answer is "further from 50%". Let me explain. Since 8 is not a large sample size, the binomial distribution of proportion of cells with paternal X-chromosome expressed is not approximately normal by the Central Limit Theorem, so the proportion of cells with paternal X chromosome expressed is less likely to deviate from the mean for the 8-cell stage.



Ethan

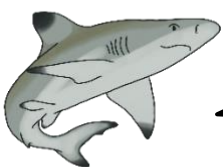

Lionel

HAHA this is a trick question! X-chromosomal inactivation has been recently proven by N. Sens et al. (2023) to only occur in some mutants. X-chromosomal inactivation rarely occurs so this question is actually invalid!

That's a great discussion everyone! However, only one of you had the correct answer and explanation to my question. Come find me after class to get a chocolate bar as your prize!



Dr Jerome (The professor)

**Q7.** Which student had both the correct answer and explanation to Dr Jerome's question and will hence be receiving a chocolate bar from him? **(20 points)**

*(Select the correct option.)*

- A. Owen
- B. Alicia
- C. Cervon
- D. Yuting
- E. Le Xuan
- F. Debraath
- G. Ethan
- H. Lionel
- I. Dr Jerome is disappointed and everyone was wrong

# P37: More Abs

(190 points)

Abscisic acid (ABA) is known to regulate dormancy of seeds and to regulate other stress responses in plants. Phytochromes are light photoreceptors that are involved in photoperception of the light environment. Faith wants to investigate the interactions between phyA and ABI1 and ABI2. She first used a light-switchable Yeast-2-Hybrid (Y2H) system to investigate whether phyA physically interacted with the components in the core ABA signalling pathway, also known as the PYR1-ABI2-OST1-ABF4 pathway (Figure 1A, B). Then she performed firefly luciferase complementation imaging (LCI) assays to investigate phyA and ABI1/2 interactions *in vivo* (Figure 1C, D, E). Finally, to investigate which domain of phyA interacted with ABI1/2, yeast assays were performed using bait vectors expressing different phyA domains fused to LexA DNA-binding domain (Figure 1F, G).



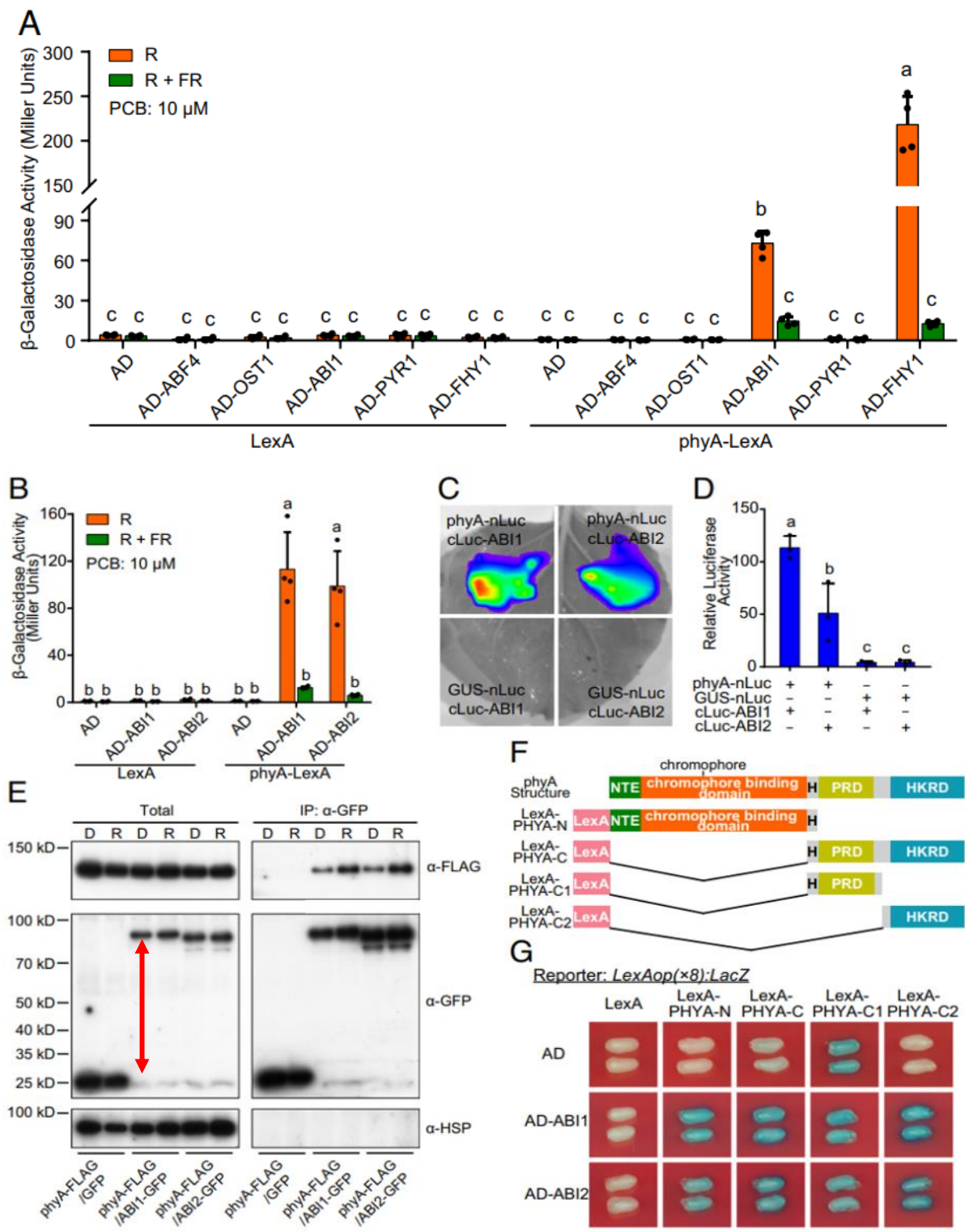

Figure 1: phyA interaction with ABI1 and ABI2. PCB is added as a substrate for phyA. **(A and B)** Y2H assays on phyA interactions with core ABA signalling pathway. **(C and D)** LCI assays on phyA interactions with ABI1/2 in leaves. **(E)** Co-IP assays. Fusion proteins were expressed in protoplasts. D: Kept in dark for 30 min. R: Red light treatment for 30 min. **(F)** Schematic diagram of bait proteins. **(G)** Assays showing ABI1 and ABI2 interactions with different domains of PHYA in the yeast cells.

**Q1.** Indicate whether the following statements are true or false. **(50 points)**

*(Mark each statement as true or false.)*

- A. AD-FHY1 was used as a negative control in Figure 1A.
- B. phyA interacts with OST1 after R light treatment.
- C. phyA interacts with ABI1 after R + FR light treatment.
- D. phyA does not interact with PYR1 regardless of light treatment.
- E. There is no significant difference in interaction between phyA and ABI1 compared to phyA and ABI2 based on Figure 1.

**Q2.** Indicate whether the following statements are true or false. **(40 points)**

*(Mark each statement as true or false.)*

- A. phyA interacts with ABI2 *in vitro* but not *in vivo*.
- B. phyA does not interact with ABI1 directly but interacts with ABI1 indirectly.
- C. Pr form of phyA interacts with ABI1 preferentially over Pfr form.
- D. The red arrow in Figure 1E indicates the molecular weight of phyA-FLAG.

**Q3.** Indicate whether the following statements are true or false. **(40 points)**

*(Mark each statement as true or false.)*

- A. The N-terminus domain of phyA can interact with ABI1.
- B. The C-terminus domain of phyA can interact with ABI1.
- C. PRD does not require ABI1 to activate the PHYA promoter.
- D. HKRD does not require ABI2 to activate the PHYA promoter.

In order to further investigate ABA signalling in plant cells, Faith designed a system in yeast cells which emulates the complete ABA-signalling pathway from ABA detection to gene expression of the related genes. The core ABA signalling module contains KF2, SBL1, ABI1, and the downstream transcription factor NON7.

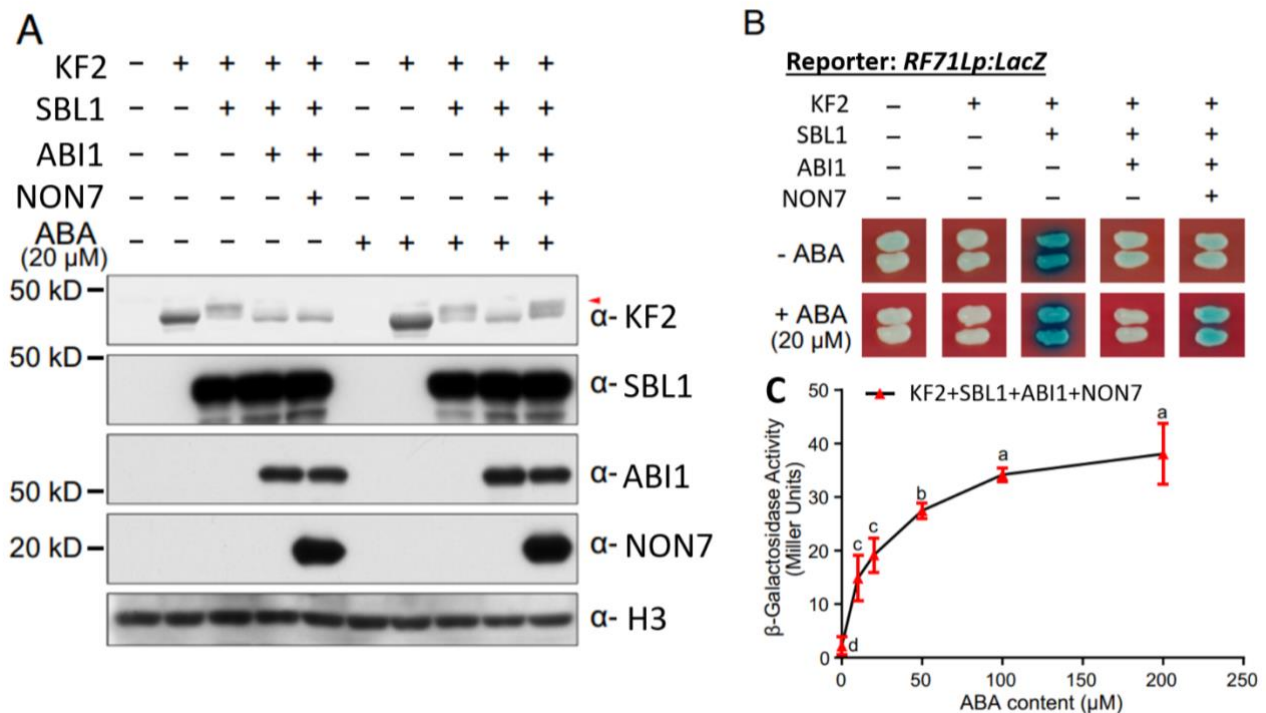

Figure 2: **(A)** Immunoblot assay of transformed yeast cells. The red arrow indicates phosphorylated form of KF2. **(B)** Assay where an ABA-sensitive promoter (*RF71L*) was fused to *LacZ* reporter gene in yeast cells. **(C)** Effects of ABA concentrations on the activation of the *RF71L* promoter in yeast reconstitution system.

**Q4.** Indicate whether the following statements are true or false. **(50 points)**

(Mark each statement as true or false.)

- KF2 is an activator protein.
- SBL1 induces phosphorylation in KF2 which causes transactivation.
- ABI1 promotes the phosphorylation ability of SBL1.
- ABI1 inhibits transactivation.
- Figure 2 supports the hypothesis that NON7 inhibits the effect of ABI1 in the presence of ABA.

**Q6.** Indicate the approximate minimum concentration of ABA required to induce a saturated activation of the *RF71L* promoter in the presence of KF2+SBL1+ABI1+NON7. **(10 points)**

*(Select the correct option.)*

- A. 0.00mM
- B. 0.05mM
- C. 0.10mM
- D. 0.15mM
- E. 0.20mM
- F. 0.25mM
- G. 0.50mM
- H. 1.0mM
- I. 15.0mM
- J. 25.0mM
- K. 50.0mM
- L. 100.0mM
- M. 150.0mM
- N. 200.0mM
- O. 250.0mM
- P. 500.0mM

# P38: U + I < 3

(210 points)

Urinary tract infections (UTIs) refer to infections of the urinary tract. UTIs caused by kidney stones can lead to damage in the kidneys, where urine is produced. Damaged kidneys can result in a fall in kidney function. A useful way of measuring kidney function is by the glomerular filtration rate (GFR), which measures the rate of filtration of the ultrafiltrate from the Glomerular Capillary (GC) to the Bowman's Space (BS).

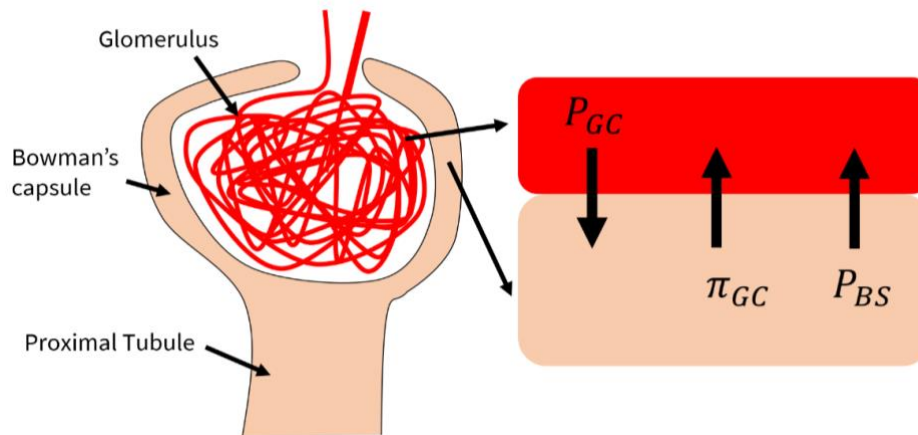

Fig 1: Glomerulus and Bowman's capsule

You may find the following equations may be useful:

$$\text{Net glomerular filtration pressure, } P_{net} = P_{GC} - P_{BS} - \pi_{GC}$$

$$\text{Glomerular filtration rate, } GFR = K_f \times P_{net}$$

$P$  refers to the hydrostatic pressure of the fluid, while  $\pi$  refers to the colloidal osmotic pressure.  $K_f$  refers to filtration rate.

There are several conditions that can affect the GFR by affecting different factors. Below is a list of possible effects on the GFR and their reason. Use these to answer **Q1** and **Q2**. For the following conditions, indicate whether GFR increases or decreases and the cause.

1. GFR increases because  $P_{GC}$  increases.
2. GFR increases because  $P_{BS}$  increases.
3. GFR increases because  $\pi_{GC}$  increases.
4. GFR increases because  $K_f$  increases.
5. GFR increases because  $P_{GC}$  decreases.
6. GFR increases because  $P_{BS}$  decreases.
7. GFR increases because  $\pi_{GC}$  decreases.
8. GFR increases because  $K_f$  decreases.
9. GFR decreases because  $P_{GC}$  increases.
10. GFR decreases because  $P_{BS}$  increases.
11. GFR decreases because  $\pi_{GC}$  increases.
12. GFR decreases because  $K_f$  increases.
13. GFR decreases because  $P_{GC}$  decreases.
14. GFR decreases because  $P_{BS}$  decreases.
15. GFR decreases because  $\pi_{GC}$  decreases.
16. GFR decreases because  $K_f$  decreases.



**Q1.** Match the correct effects on GFR of the following conditions and their corresponding reason

(1-16) **(30 points)**

*(Match the correct number to the correct row.)*

<b>Condition</b>	<b>Effect on GFR (1-16)</b>
Diabetes mellitus	
Adrenaline rush	
Blockage in tubular lumen by uric acid crystal	

**Q2.** Match the correct effects on GFR of the following conditions and their corresponding reason

(1-16) **(30 points)**

*(Match the correct number to the correct row.)*

<b>Condition</b>	<b>Effect on GFR (1-16)</b>
Acute hypertension	
Acute heart failure	
Increased albumin synthesis by liver	

A useful way of quantifying renal function is in terms of clearance. The renal clearance of any substance is the volume of plasma from which the substance is completely removed (“cleared”) by the kidneys per unit time. The concept is based on the conservation of mass, where any substance that is cleared from the blood by the kidneys must be found in the urine.

$$C_S = \frac{U_S \times V}{P_S}$$

Where  $C_S$  is clearance of S,  $U_S$  is urine concentration of S,  $V$  is urine flow rate and  $P_S$  is plasma concentration of S.

**Q3.** Indicate whether the following statements are true or false. **(40 points)**

*(Mark each statement as true or false.)*

- The renal clearance of glucose of a patient with diabetes mellitus is greater than a normal, healthy human.
- A substance that is freely filtered, but neither secreted nor reabsorbed, can be used to measure the renal plasma flow.
- Renal clearance is always less than GFR.
- Assuming all other factors are kept constant, an increase in secretion of ADH by the posterior pituitary results in a change in clearance of most substances.

The osmolarity of the intracellular fluids and extracellular fluids can be affected by different conditions. Figure 2 shows the graph of osmolarity against volume of the intracellular and extracellular fluids of a normal person.

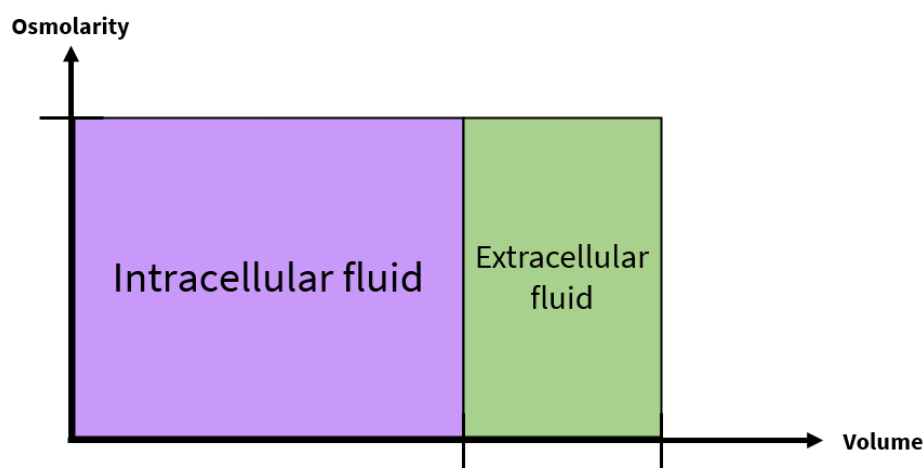

Figure 2: Graph of osmolarity against volume of the intracellular and extracellular fluids of a normal person. Axes markers have been indicated to indicate the values of the x and y-axes for the normal person.

Figure 3 shows possible effects on the graph in Figure 2 due to changes in conditions.

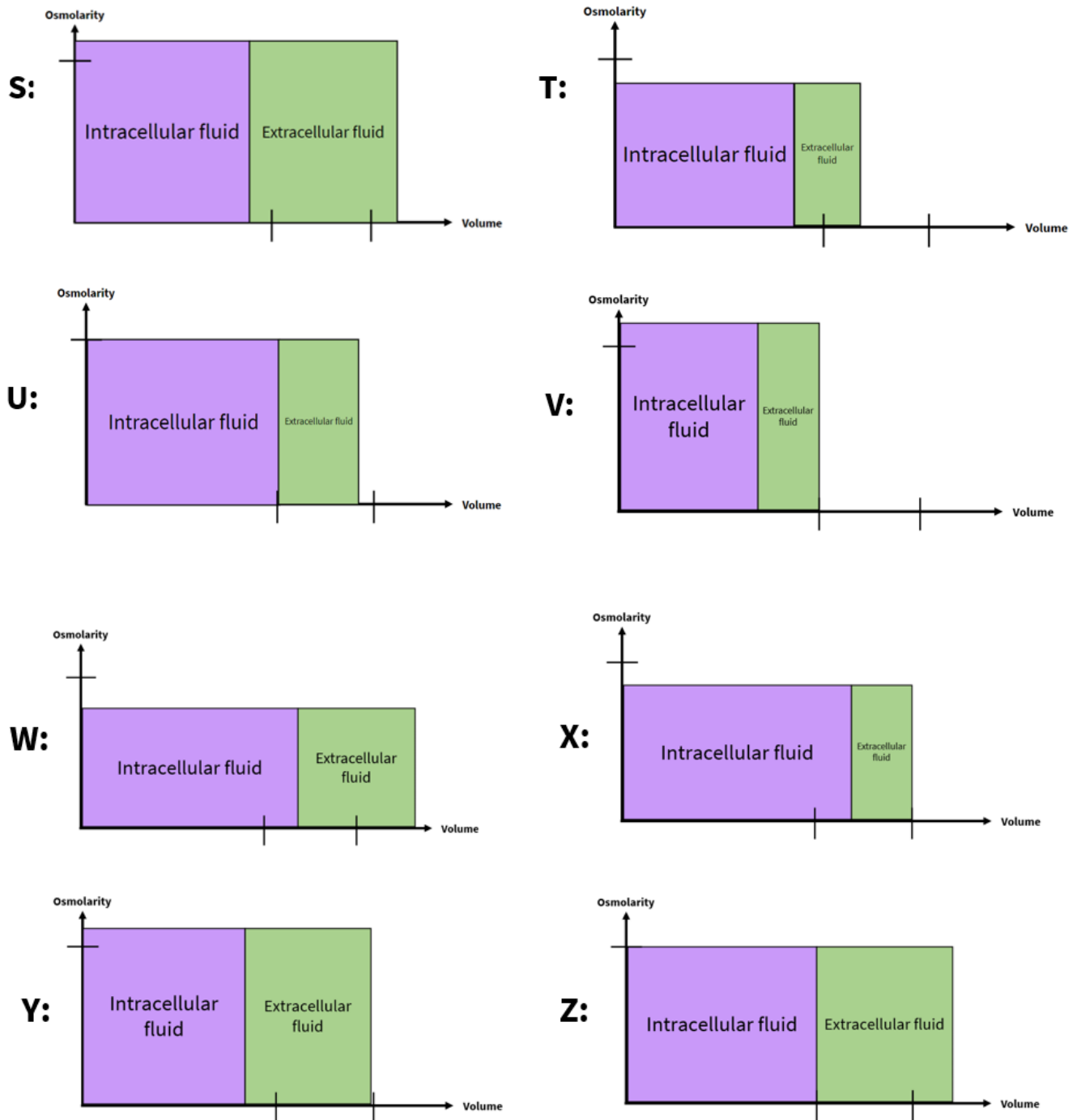

Figure 3: Possible changes in graph. The axes markers indicate the values of the x and y-axes for the normal person (Figure 2).



**Q4.** Match the following solutions to the correct effect on the graph (S-Z) when NaCl solutions with varying concentrations are ingested. If there is no change, enter *No change*. **(30 points)**  
(Match the correct letter to the correct row.)

Solution added	Graph (U-Z)
3% NaCl saline	
0.9% NaCl saline	
0.3% NaCl saline	

**Q5.** Certain conditions can also result in the changes seen in Figure 3. Match the following conditions to the correct effect of it on the graph (S-Z). If there is no change, enter *No change*. If the graph is not in Figure 3, enter None. **(40 points)**  
(Match the correct letter to the correct row.)

Condition	Graph (U-Z)
Hypersecretion of ADH	
Primary hyperaldosteronism	
Right after eating potato chips	
Inability of kidney to respond to ADH	

Bartter's Syndrome is a rare disorder involving the kidneys. It occurs due to a rare autosomal-recessive allele that impairs the function of the 1-sodium, 2-chloride, 1-potassium cotransporter (NKCC), which is responsible for the active transport of solutes from the tubular lumen to the medullary interstitial fluid in the ascending loop of Henle.

**Q6.** Determine if the following statements are true or false. **(40 points)**  
(Mark each statement as true or false.)

- If both parents do not have Bartter's Syndrome, it is impossible for any of their children to have Bartter's Syndrome (assuming no mutations).
- The hyperosmotic medullary interstitial fluid will become less hyperosmotic relative to the rest of the body.
- The ability of the kidneys to excrete hyperosmotic urine will be reduced.
- Furosemide, an NKCC inhibitor, can treat Bartter's Syndrome.

# P39: Heat. Cool. Multiply.

(220 points)

Figure 1 shows the stages of a polymerase chain reaction (PCR).

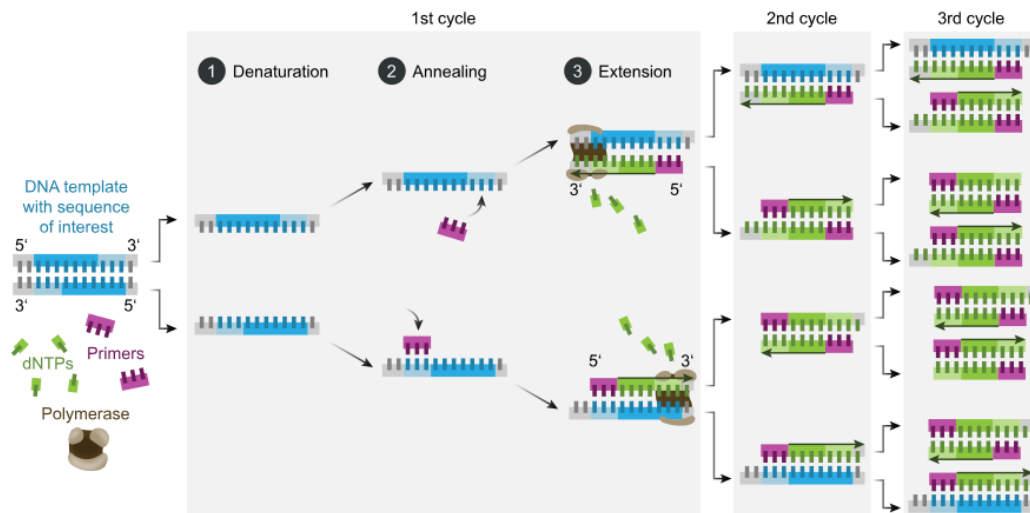

Figure 1: Schematic diagram of stages of polymerase chain reaction (PCR)

Dr Ace carries out a PCR reaction to amplify a region of interest, starting with 10 nmol of genomic DNA. Dr Ace is very fastidious about the product obtained from the PCR. He wants to know exactly how much product with the correct strand length he will obtain in each cycle. This means that his definition of “product” is a dsDNA molecule with the exact length of the region of interest.

We first assume no mutations in the PCR.

**Q1.** How many nanomoles of product (dsDNA with the correct strand length) does he have after 1 PCR cycle? **(10 points)**

*(Enter your answer correct to 3 s.f. Do not include any units.)*

**Q2.** How many nanomoles of product (dsDNA with the correct strand length) does he have after 2 PCR cycles? **(10 points)**

*(Enter your answer correct to 3 s.f. Do not include any units.)*

**Q3.** How many nanomoles of product (dsDNA with the correct strand length) does he have after 3 PCR cycles? **(10 points)**

*(Enter your answer correct to 3 s.f. Do not include any units.)*

**Q4.** How many **micromoles** of product (dsDNA with the correct strand length) does he have after 15 PCR cycles? **(30 points)**

*(Enter your answer correct to 3 s.f. Do not include any units.)*

Now, mutations are not negligible and have to be accounted for. Assume that the rate of error in DNA replication by *Taq* polymerase is 1 error per 10000 nucleotides. Given that the length of the region of interest is 220 base pairs and the reverse and forward primers are 20 base pairs each (assume no mutation in primers), help Dr Ace figure out how much product he will obtain below.

**Q5.** How many nanomoles of product (dsDNA with the correct strand length with no mutations) does he have after 3 PCR cycles? **(30 points)**

*(Enter your answer correct to 3 s.f. Do not include any units.)*

**Q6.** What is the minimum number of cycles required to get 1 mmol of product (dsDNA with the correct strand length with no mutations)? *(Hint: the use of Excel may be very helpful.)* **(40 points)**

*(Enter your answer correct to 3 s.f. Do not include any units.)*

Dr Ace is annoyed by the changes in the calculation required when mutations are taken into account. Hence, he decided that from now on, we can assume that there are no mutations unless otherwise stated.

Dr Ace wants to amplify a 400-bp gene of interest found in the mitochondria of blue fiddler crabs (*Tubuca paradussumieri*). He decides to get creative and decides to perform some modifications on his PCR protocol to investigate whether PCR will still be carried out normally and the desired product is obtained.

Dr Ace's original protocol along with four other protocols with modifications are shown below.

**Original protocol:** Dr Ace mixes the linear gene of interest in an Eppendorf tube with a large excess of 20-bp primers (>100x of final expected dsDNA products) and adds buffer mix. He then adds excess dNTPs and *Taq* polymerase. Dr Ace then inverts the tube multiple times and places it in a thermocycler set at 35 PCR cycles of 1. 95°C / 2. 60°C / 3. 72°C. After the last cycle, the mixture is immediately cooled to 15°C and the desired dsDNA products are collected.

**Results:**  $n$  moles of product were obtained.

Protocol	Modifications
Protocol 1	Dr Ace changed the order of the thermocycle from 1. 95°C / 2. 60°C / 3. 72°C to 1. 60°C / 2. 72°C / 3. 95°C.
Protocol 2	Dr Ace used 60-bp primers instead of 20-bp primers. The annealing temperature is optimal based on the melting temperatures of the two 60-bp primers.
Protocol 3	Dr Ace added DNA helicase (and relevant cofactors and accessory proteins like single-strand DNA-binding proteins (SSB)) to the Eppendorf tube. He did not use the

	thermocycler but instead left the mixture to incubate for 4h at 37°C. He subsequently then collected the desired product.
Protocol 4	Dr Ace added two 20-bp primers (in excess) to the Eppendorf tube. These primers anneal to the centre of the gene of interest (See Figure 2).
Protocol 5	Dr Ace used a more heat-sensitive polymerase (Polymerase <i>K</i> ) than <i>Taq</i> polymerase instead.

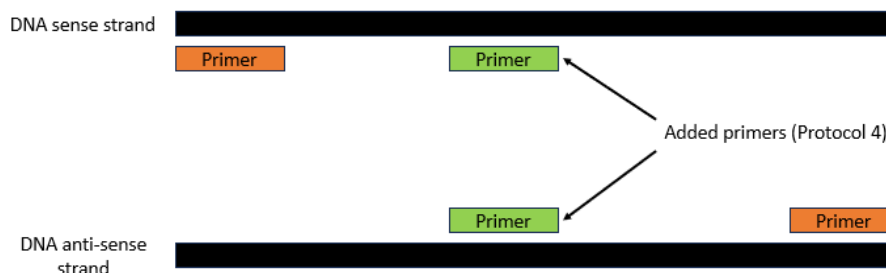

Figure 2: Protocol 4 Primers

**Q7.** Indicate whether the following statements are true or false. **(50 points)**

(Mark each statement as true or false.)

- PCR has rendered gene cloning by transformation of *E. coli* relatively obsolete.
- The product must be circularised before it can be used for further analysis (such as Southern Blot).
- Taq* polymerase synthesises dsRNA to amplify mRNA in cells to measure gene expression levels.
- The amount of product obtained in Protocol 1 will be significantly reduced as compared to the original protocol.
- Assuming mutations are not negligible, a higher proportion of the products obtained in Protocol 2 will have mutations as compared to the original protocol.

**Q8.** Indicate whether the following statements are true or false. **(40 points)**

(Mark each statement as true or false.)

- Dr Ace would likely still be able to obtain his desired product in Protocol 3.
- Polymerase *K* likely has more cysteine residues than *Taq* polymerase.
- A similar amount of product will be obtained in Protocol 4 as compared to the original protocol.
- A lower amount of product will be obtained in Protocol 5 as compared to the original protocol.

# P40: Anaemia

(180 points)

## The Intriguing Case of Thalassaemias

Thalassaemias are a type of anaemia found in humans. The underlying pathophysiology of the thalassaemias involves an imbalance in the synthesis of haemoglobin alpha ( $\alpha$ -) and beta ( $\beta$ -) globins. Owing to deficiency in either globin chain, the other chain is in excess, causing the unpaired chains to precipitate as insoluble inclusions.

Due to gene duplication, humans have two  $\alpha$ -globin genes on chromosome 16, making for a total of four of these genes in the diploid genome.  $\alpha$ -thalassaemia trait refers to deletion of two out of four of these genes. Both deletions may occur on the same chromosome (more common in population X) or one deletion on each chromosome (more common in African population Y). Clinically significant  $\alpha$ -thalassaemia develops when three or more of these genes are deleted.

**Q1.** Indicate whether the following statements are true or false. **(40 points)**

*(Mark each statement as true or false.)*

- A. Persons with  $\beta$ -thalassaemia are likely to have an excess of the form of bilirubin that is soluble in water.
- B. Mutations that create new splice sites are likely to result in a reduction in  $\beta$ -globin synthesis rather than an absence of  $\beta$ -globin synthesis.
- C. Persons with deletions in both  $\alpha$ - and  $\beta$ -globin genes are likely to have more severe symptoms than those with an equivalent number of deletions but in the  $\alpha$ - or  $\beta$ -globin genes only.
- D. Clinically significant  $\alpha$ -thalassaemia is likely to be more common in population X than population Y.

## Types of Anaemia

Anaemia refers to a low level of red blood cells (RBCs). The following table shows several types of anaemia.

Code	Type of Anaemia	Description
I	Hereditary spherocytosis	Mutations in proteins e.g. ankyrin, spectrin tethering cytoskeleton to plasma membrane causes RBCs to shed membrane fragments, becoming spheroid, less deformable and vulnerable to splenic destruction
II	Glucose-6-phosphate dehydrogenase (G6PD) deficiency	X-linked recessive disorder in which lack of G6PD renders RBCs susceptible to oxidant stress
III	Sickle cell anaemia	Mutation in haemoglobin beta globin resulting in formation of rigid fibres that cause RBCs to become sickle-shaped. May lead to autosplenectomy.
IV	Beta thalassaemia	Mutations resulting in absent or reduced haemoglobin beta globin synthesis
V	Alpha thalassaemia	Mutations resulting in absent or reduced haemoglobin alpha globin synthesis
VI	Paroxysmal nocturnal haemoglobinuria	X-linked mutation in phosphatidylinositol glycan complementation group A (PIGA) gene resulting in deficiency of glycosylphosphatidylinositol (GPI) anchored proteins. Due to increase in complement activity when blood pH falls during sleep.
VII	Immunohaemolytic anaemia	Caused by antibodies binding to RBCs
VIII	Pernicious anaemia	Caused by deficiency in vitamin B12 required for erythropoiesis
IX	Folate-deficiency anaemia	Caused by deficiency in folate required for erythropoiesis
X	Iron-deficiency anaemia	Results from dietary lack of iron or chronic blood loss

The normal laboratory values for several haematologic measurements are shown below.

Measurement	Reference range
Haematocrit	Male: 41-50%   Female: 36-46%
Haemoglobin	Male: 13.5-16.5 g/dL   Female: 12.0-15.0 g/dL
Mean corpuscular haemoglobin (MCH)	26-34 pg/cell
Mean corpuscular volume (MCV)	80-100 $\mu\text{m}^3$

For **Q2** to **Q8**, while the information provided is not sufficient to establish a definitive diagnosis, it is known that each patient suffers from one of the anaemic conditions listed above. Use the given history of the patient to help deduce from which form of anaemia each patient is likely to suffer.

**Q2.** A man complains of nausea and vomiting in the past few months. Laboratory findings show haematocrit of 38%, haemoglobin of 12.8 g/dL, MCH of 37 pg/cell, and MCV of  $120\mu\text{m}^3$ . His gastric pH is higher than normal, but he denies taking any proton pump inhibitors recently. Endoscopic biopsy reveals degeneration of gastric glands in the stomach mucosa. Urease breath test is negative. Antibodies against parietal cells are detected in the plasma. Enter the code (I-X) corresponding to the type of anaemia which most likely accounts for these results. **(20 points)**  
(Enter a roman numeral.)

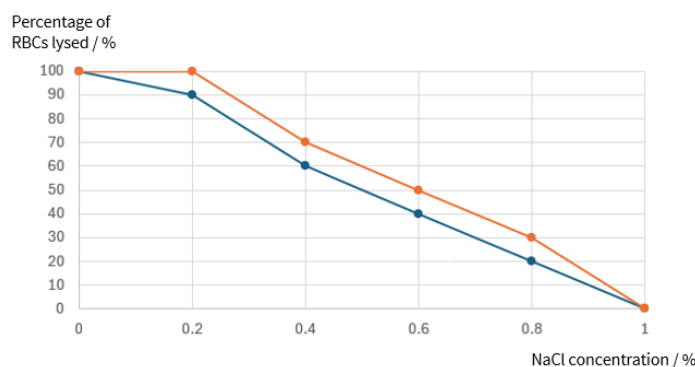

Figure 1: Percentage of RBCs lysed at different NaCl concentrations. Blue: Normal, Orange: Patient

**Q3.** A woman presents to the clinic with a pale appearance. She has haematocrit of 34% and MCV of  $90\mu\text{m}^3$ . When her RBCs are mixed with antibodies specific for immunoglobulin, no agglutination occurs. Figure 1 shows the percentage of RBCs lysed at different NaCl concentrations. Enter the code (I-X) corresponding to the type of anaemia which most likely accounts for these results. **(20 points)**  
(Enter a roman numeral.)

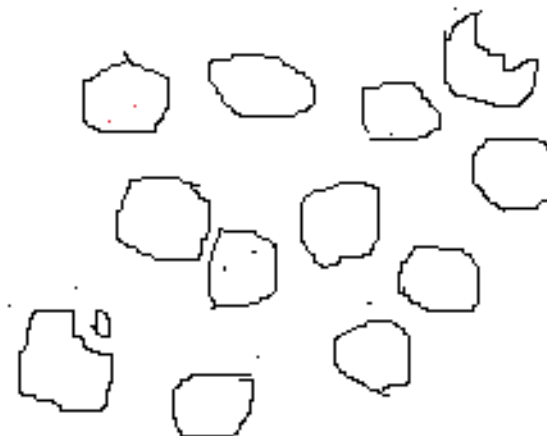

Figure 2: Peripheral blood smear

**Q4.** An African boy presents to the clinic with malaise and jaundice. He has haematocrit of 34% and MCV of  $90\mu\text{m}^3$ . His spleen is normal on examination. When his RBCs are mixed with antibodies specific for immunoglobulin, no agglutination occurs. He recently contracted malaria, but recovered after treatment was given. Figure 2 shows a representative drawing of his peripheral blood smear. Enter the code (I-X) corresponding to the type of anaemia which most likely accounts for these results. **(20 points)**

*(Enter a roman numeral.)*

**Q5.** A man presents to the clinic alarmed that his urine is reddish-brown in colour. He has haematocrit of 38% and MCH of 12.6 g/dL. His spleen is normal on examination. When his RBCs are mixed with antibodies specific for immunoglobulin, no agglutination occurs. Enter the code (I-X) corresponding to the type of anaemia which most likely accounts for these results. **(20 points)**

*(Enter a roman numeral.)*

**Q6.** A girl has presented to the clinic multiple times with fever and cough, with sputum cultures growing *Haemophilus influenzae*. She has also reported occasions of intense pain in her chest. Laboratory findings show haematocrit of 22%, haemoglobin of 6.5 g/dL, MCH of 30 pg/cell and MCV of  $88\mu\text{m}^3$ . Enter the code (I-X) corresponding to the type of anaemia which most likely accounts for these results. **(20 points)**

*(Enter a roman numeral.)*

**Q7.** A woman who gave birth to a healthy child two years ago has just delivered her second child. The newborn appears jaundiced and has an enlarged abdomen. It is previously known that the mother has blood type A, and the boy has blood type O. Enter the code (I-X) corresponding to the type of anaemia which most likely accounts for these results. **(20 points)**

*(Enter a roman numeral.)*





**Q8.** An elderly woman presents to the clinic complaining of weakness and malaise. She has experienced significant weight loss over the past 4 months. She also reports loss of appetite, nausea and vomiting, as well as having very dark-coloured stools in the recent few weeks. Blood test results reveal haematocrit of 33%, haemoglobin of 8 g/dL, MCH of 16 pg/cell, and MCV of 59  $\mu\text{m}^3$ . A diagnosis of colorectal cancer is made. Enter the code (I-X) corresponding to the type of anaemia which most likely accounts for these results. **(20 points)**

*(Enter a roman numeral.)*